

การออกแบบรายงานเครื่องแลกเปลี่ยนความร้อนและโครงสร้างการควบคุมของ
โรงงานแก๊สธรรมชาติแบบขยายตัว



นายอุทัย กายพันธ์

ศูนย์วิทยทรัพยากร
จุฬาลงกรณ์มหาวิทยาลัย

วิทยานิพนธ์นี้เป็นส่วนหนึ่งของการศึกษาตามหลักสูตรปริญญาวิศวกรรมศาสตรมหาบัณฑิต

สาขาวิชาวิศวกรรมเคมี ภาควิชาวิศวกรรมเคมี

คณะวิศวกรรมศาสตร์ จุฬาลงกรณ์มหาวิทยาลัย

ปีการศึกษา 2551

ลิขสิทธิ์ของจุฬาลงกรณ์มหาวิทยาลัย

DESIGN OF HEAT EXCHANGER NETWORKS AND CONTROL
STRUCTURES FOR NATURAL GAS EXPANDER PLANT



Mr.Uthai Gayapan

ศูนย์วิทยทรัพยากร
จุฬาลงกรณ์มหาวิทยาลัย

A Thesis Submitted in Partial Fulfillment of the Requirements
for the Degree of Master of Engineering Program in Chemical Engineering
Department of Chemical Engineering
Faculty of Engineering
Chulalongkorn University
Academic Year 2008
Copyright of Chulalongkorn University

Thesis Title DESIGN OF HEAT EXCHANGER NETWORKS AND
 CONTROL STRUCTURES FOR NATURAL GAS
 EXPANDER PLANT

By Mr.Uthai Gayapan

Field of study Chemical Engineering

Advisor Assistant Professor Montree Wongsri, D.Sc.

Accepted by the Faculty of Engineering, Chulalongkorn University in Partial
Fulfillment of the Requirements for the Master's Degree.

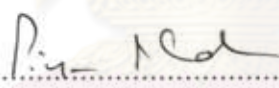

..... Dean of the Faculty of Engineering
(Associate Professor Boonsom Lerdhirunwong, Dr.Ing.)

THESIS COMMITTEE

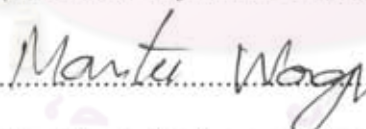
..... Chairman
(Professor Piyasan Praserttham, Dr.Ing.)

..... Advisor
(Assistant Professor Montree Wongsri, D.Sc.)

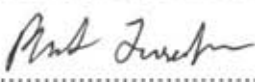
..... Examiner
(Soorathep Kheawhom, Ph.D.)

..... External Examiner
(Phisit Jaisathaporn, Ph.D.)

อุทัย ภายพันธ์ : การออกแบบข่ายงานเครื่องแลกเปลี่ยนความร้อนและโครงสร้างการควบคุม
ของโรงงานแก๊สธรรมชาติแบบขยายตัว. (DESIGN OF HEAT EXCHANGER NETWORKS
AND CONTROL STRUCTURES FOR NATURAL GAS EXPANDER PLANT) อ.ที่ปรึกษา
วิทยานิพนธ์หลัก : ผู้ช่วยศาสตราจารย์ ดร. มนต์รี วงศ์ศรี, 221 หน้า.

การนำกลับคืนพลังงานโดยผ่านข่ายงานเครื่องแลกเปลี่ยนความร้อนเป็นขั้นตอนที่สำคัญใน
กระบวนการเคมี การแลกเปลี่ยนพลังงานภายในกระบวนการจะทำให้เกิดผลกระทบซึ่งกันและกัน
ภายในกระบวนการและอาจจะทำให้อุณหภูมิยากในการรักษาอุณหภูมิเป้าหมายอีกด้วย ดังนั้นเพื่อ
ทำให้ข่ายงานบรรลุเป้าหมาย (อุณหภูมิเป้าหมายและการนำกลับคืนพลังงานสูงสุด) การออกแบบ
ข่ายงานเครื่องแลกเปลี่ยนความร้อนแบบยืดหยุ่นซึ่งสามารถจัดการกับความแปรปรวนที่เกิดขึ้นได้จึง
เป็นสิ่งสำคัญ นอกจากนี้ควรพิจารณาการใช้กลยุทธ์การควบคุมแบบแพลนท์ไวด์ร่วมด้วย ในงานวิจัย
นี้ได้ทำการจำลองข่ายงานเครื่องแลกเปลี่ยนความร้อนจำนวน 9 ทางเลือก (ทางเลือกที่สร้างใหม่ 8
ทางเลือกกับทางเลือกฐาน) และออกแบบโครงสร้างการควบคุม 3 แบบของโรงงานแก๊สธรรมชาติ
ออกแบบข่ายงานเครื่องแลกเปลี่ยนความร้อนแบบยืดหยุ่นโดยการใช้วิธีการถ่ายโอนความแปรปรวน
ของวงศ์ศรี (1990) และโครงสร้างการควบคุมของข่ายงานนี้ใช้อัลกอริทึมของวงศ์ศรี (1990) ส่วนการ
ควบคุมแบบแพลนท์ไวด์จะใช้วิธีการออกแบบของ Luyben (1999) สำหรับโครงสร้าง CS1 และใช้
ทฤษฎี "Fixture point" ของวงศ์ศรี (2008) ออกแบบโครงสร้าง CS2 และ CS3 ผลการศึกษาชี้ให้เห็น
ว่าโครงสร้างการควบคุม CS3 สามารถปฏิเสธตัวรบกวนได้ดีกว่าโครงสร้างการควบคุมอื่น โครงสร้าง
การควบคุมที่ออกแบบนี้ได้ถูกประเมินค่าอย่างเข้มงวดโดยใช้โปรแกรมจำลองกระบวนการทาง
การค้าไฮซิส (HYSYS)

ภาควิชา.....วิศวกรรมเคมี.....
สาขาวิชา.....วิศวกรรมเคมี.....
ปีการศึกษา.....2551.....

ลายมือชื่อนิสิต.....อุทัย ภายพันธ์.....
ลายมือชื่ออ.ที่ปรึกษาวิทยานิพนธ์หลัก.....

##5070525021 : MAJOR CHEMICAL ENGINEERING

KEYWORDS : NATURAL GAS EXPANDER PLANT / HEAT EXCHANGER NETWORKS / PLANTWIDE CONTROL STRATEGIES

UTHAI GAYAPAN : DESIGN OF HEAT EXCHANGER NETWORKS AND CONTROL STRUCTURES FOR NATURAL GAS EXPANDER PLANT. ADVISOR : ASST. PROF. MONTREE WONGSRI, D.Sc., 221 pp.

Energy recovery by heat exchanger network (HEN) is the important stage in chemical process. The energy integration causes to the interactions and may cause the process more difficult to control. Therefore, in order to achieve maximum energy recovery and keep target value at their desirable value, the resilient heat exchanger networks that can tolerate variations are important. Furthermore, the plantwide control strategies of the process should be considered. In this research, nine alternatives (8 new alternative designs and base case) of heat exchanger networks and three control structure designs of the natural gas expander plant are proposed. The resilient heat exchanger networks are designed using the disturbance load propagation method (Wongsri, 1990) and the control structures of HENs using the heat pathway heuristics (Wongsri and Hermawan, 2005). The plantwide control structures are designed by using Luyben heuristic design method (1999) for the CS1 control structure and Fixture point theorem (Wongsri, 2008) for the CS2 and CS3 control structure. The result shows the CS3 control structure can reject disturbances better than other control structures. The designed control structure is evaluated based on the rigorous dynamic simulation using the commercial software HYSYS.

Department:.....Chemical Engineering...

Field of Study:....Chemical Engineering...

Academic Year:...2008.....

Student's Signature:.....*Uthai Gayapan*.....

Advisor's Signature:.....*M. Wongsri*.....

ACKNOWLEDGEMENTS

Foremost, I would like to express my most sincere thanks to my advisor, Assistant Professor Montri Wongsri, for his guidance and support. Special thanks belong to Professor Piyasan Prasertdham, Dr. Soorathep Kheawhom and Dr. Pisit Jaisathaporn for kindly serving as my committee members.

Many thanks for all of the members in the process control laboratory and friends who have contributed to the accomplishment of the work. I would like to express my gratitude to all those who encouraged over the years of my study at Chulalongkorn University.

Finally, I would like to express the highest gratitude to all of family for their love, inspiration, encouragement and financial support throughout this study.



ศูนย์วิทยทรัพยากร
จุฬาลงกรณ์มหาวิทยาลัย

CONTENTS

	page
ABSTRACT (THAI).....	iv
ABSTRACT (ENGLISH).....	v
ACKNOWLEDGEMENTS.....	vi
CONTENTS.....	vii
LIST OF TABLES.....	xi
LIST OF FIGURES.....	xiv
CHAPTER	
I INTRODUCTION.....	1
1.1 Importance and Reasons for Research.....	1
1.2 Research Objectives.....	3
1.3 Scopes of Research.....	3
1.4 Contributions of Research.....	3
1.5 Research Procedures.....	4
1.6 Research Contents.....	4
II LITERATURE REVIEWS.....	6
2.1 Heat Exchanger Networks (HENs).....	6
2.2 Design and Control of Integrated Plants.....	11
III THEORIES.....	14
3.1 Basic Knowledge for Pinch Technology.....	15
3.1.1 Pinch Technology.....	15
3.1.2 Basic Pinch Analysis Concept.....	15
3.2 Heat Exchanger Networks.....	18
3.2.1 Definition of HEN Resiliency.....	19
3.2.2 Heuristics for HEN Synthesis.....	19
3.2.3 Math Classification.....	21
3.2.4 Match Patterns.....	22
3.2.5 Disturbance Propagation Design Method.....	35
3.2.6 Synthesis Procedure.....	38

CHAPTER	page
3.3 Plantwide Control.....	38
3.3.1 Integrated Process.....	39
3.3.2 Effects of Recycle.....	41
3.3.3 Plantwide Control Design Procedures.....	42
3.4 Control of process-to-process exchanger.....	46
3.4.1 Use of Bypass Control.....	47
3.4.2 Use of Auxiliary Exchangers.....	48
3.5 Cascade Control.....	49
IV PROCESS AND DESIGN.....	51
4.1 Process Description.....	51
4.2 Design of Heat Exchanger Networks.....	52
4.2.1 HEN Base Case.....	54
4.2.2 HEN Alternative 1.....	54
4.2.3 HEN Alternative 2.....	56
4.2.4 HEN Alternative 3.....	57
4.2.5 HEN Alternative 4.....	59
4.2.6 HEN Alternative 5.....	60
4.2.7 HEN Alternative 6.....	62
4.2.8 HEN Alternative 7.....	64
4.2.8 HEN Alternative 8.....	65
4.3 Testing the Networks.....	67
V CONTROL STRUCTURE DESIGN.....	76
5.1 Plantwide Control Strategies.....	76
5.1.1 Nine-step approach of Luyben.....	76
5.1.2 Fixture Point Theorem.....	79
5.2 Design of Plantwide Control Structures.....	79
5.2.1 Design of control structures for TEP base case.....	81
5.2.2 Design of control structures for TEP Alternative 1....	82
5.2.3 Design of control structures for TEP Alternative 2....	83

CHAPTER	page
5.2.4 Design of control structures for TEP Alternative 3....	84
5.2.5 Design of control structures for TEP Alternative 4....	85
5.2.6 Design of control structures for TEP Alternative 5....	85
5.2.7 Design of control structures for TEP Alternative 6....	86
5.2.8 Design of control structures for TEP Alternative 7....	86
5.2.9 Design of control structures for TEP Alternative 8....	87
5.3 Dynamic Simulation Results.....	124
5.3.1 Dynamic Simulation Results for TEP base case.....	124
5.3.2 Dynamic Simulation Results for TEP Alternative 1...	133
5.3.3 Dynamic Simulation Results for TEP Alternative 2...	135
5.3.4 Dynamic Simulation Results for TEP Alternative 3...	149
5.3.5 Dynamic Simulation Results for TEP Alternative 4...	151
5.3.6 Dynamic Simulation Results for TEP Alternative 5...	165
5.3.7 Dynamic Simulation Results for TEP Alternative 6...	167
5.3.8 Dynamic Simulation Results for TEP Alternative 7...	181
5.3.9 Dynamic Simulation Results for TEP Alternative 8...	183
5.4 Evaluation of the Dynamic Performance.....	197
5.4.1 Evaluation of the Dynamic Performance for CS1 Control Structure.....	197
5.4.2 Evaluation of the Dynamic Performance for CS2 Control Structure.....	198
5.4.3 Evaluation of the Dynamic Performance for CS3 Control Structure.....	199
5.4.4 Evaluation of the Dynamic Performance for All Control Structures.....	199
VI CONCLUSIONS AND RECOMMONDATIONS.....	203
6.1 Conclusion.....	203
6.2 Recommendations.....	204
REFERENCES.....	205

CHAPTER	page
APPENDICES.....	208
Appendix A.....	209
Appendix B.....	213
Appendix C.....	216
VITA.....	221



ศูนย์วิทยทรัพยากร
จุฬาลงกรณ์มหาวิทยาลัย

LIST OF TABLES

	page
Table 3.1 Thermal data for process streams (Linnhoff and Hindmarsh, 1983).....	16
Table 3.2 The problem table for data given in Table 3.1.....	17
Table 3.3 Match Pattern Operators of Class A and B.....	27
Table 3.4 Match Pattern Operators of Class C and D.....	28
Table 3.5 Splitting Match Pattern Operators.....	33
Table 3.6 Splitting Match Pattern Operators.....	34
Table 3.7 Splitting Match Pattern Operators.....	35
Table 4.1 The information of the natural gas expander plant.....	53
Table 4.2 Process stream data for all alternatives.....	53
Table 4.3 Synthesis Table for Alternative 1.....	55
Table 4.4 Synthesis Table for Alternative 2.....	56
Table 4.5 Synthesis Table for Alternative 3.....	58
Table 4.6 Synthesis Table for Alternative 4.....	60
Table 4.7 Synthesis Table for Alternative 5.....	61
Table 4.8 Synthesis Table for Alternative 6.....	63
Table 4.9 Synthesis Table for Alternative 7.....	64
Table 4.10 Synthesis Table for Alternative 8.....	66
Table 5.1 Control Structure and Controller Parameter for the TEP Base Case: Control Structure 1 (CS1), Control Structure 2 (CS2) and Control Structure 3 (CS3).....	88
Table 5.2 Control Structure and Controller Parameter for the TEP Alternative 1: Control Structure 1 (CS1), Control Structure 2 (CS2) and Control Structure 3 (CS3).....	92
Table 5.3 Control Structure and Controller Parameter for the TEP Alternative 2: Control Structure 1 (CS1), Control Structure 2 (CS2) and Control Structure 3 (CS3).....	96
Table 5.4 Control Structure and Controller Parameter for the TEP	

	page
Table 5.5	Alternative 3: Control Structure 1 (CS1), Control Structure 2 (CS2) and Control Structure 3 (CS3)..... 100 Control Structure and Controller Parameter for the TEP
Table 5.6	Alternative 4: Control Structure 1 (CS1), Control Structure 2 (CS2) and Control Structure 3 (CS3)..... 104 Control Structure and Controller Parameter for the TEP
Table 5.7	Alternative 5: Control Structure 1 (CS1), Control Structure 2 (CS2) and Control Structure 3 (CS3)..... 108 Control Structure and Controller Parameter for the TEP
Table 5.8	Alternative 6: Control Structure 1 (CS1), Control Structure 2 (CS2) and Control Structure 3 (CS3)..... 112 Control Structure and Controller Parameter for the TEP
Table 5.9	Alternative 7: Control Structure 1 (CS1), Control Structure 2 (CS2) and Control Structure 3 (CS3)..... 116 Control Structure and Controller Parameter for the TEP
Table 5.10a	Alternative 8: Control Structure 1 (CS1), Control Structure 2 (CS2) and Control Structure 3 (CS3)..... 120 The IAE results of the CS1 control structure to the change in the natural gas feed temperature..... 200
Table 5.10b	The IAE results of the CS1 control structure to the change in the natural gas feed flow rate..... 200
Table 5.11a	The IAE results of the CS2 control structure to the change in the natural gas feed temperature..... 201
Table 5.11b	The IAE results of the CS2 control structure to the change in the natural gas feed flow rate..... 201
Table 5.12a	The IAE results of the CS3 control structure to the change in the natural gas feed temperature..... 202
Table 5.12a	The IAE results of the CS3 control structure to the change in the natural gas feed flow rate..... 202

	page
Table 5.13	The IAE summation of the control structure to the change in all disturbances testing..... 202
Table A.1	Typical measurement lags..... 212
Table B.1	Data of the natural gas expander plant (Base Case) for simulation..... 213
Table B.2	Equipment data and specification of natural gas expander plant..... 214
Table C.1	List of Manipulated Variables for the TEP..... 216
Table C.2	IAE Results of Flow Rate Deviation for the Process Stream..... 217
Table C.3	IAE Results of Pressure Deviation for the Process Stream..... 218
Table C.4	IAE Results of Temperature Deviation for the Process Stream..... 219
Table C.5	IAE Results of Composition, Level and Tray Temperature Deviation for the Process Stream..... 220

LIST OF FIGURES

		page
Figure 3.1	Class A Match Pattern.....	24
Figure 3.2	Class B Match Pattern.....	25
Figure 3.3	Class C Match Pattern.....	24
Figure 3.4	Class D Match Pattern.....	25
Figure 3.5	A Concept of Propagated Disturbance.....	37
Figure 3.6	A General Concept of Propagated Disturbance.....	37
Figure 3.7	Integrated Process flowsheet.....	39
Figure 3.8	Control of P/P heat exchangers.....	46
Figure 3.9	Bypass controls of process-to process heat exchangers.....	48
Figure 3.10	Cascade control in distillation column reboiler.....	50
Figure 4.1	Simplified flowsheet of the turbo-expander plant (TEP) (Konukman and Akman, 2005).....	52
Figure 4.2	The flowsheet of the HEN base case in the form of grid diagram.....	52
Figure 4.3	The heat exchanger network of Alternative 1, HEN-1.....	25
Figure 4.4	The heat exchanger network of Alternative 2, HEN-2.....	56
Figure 4.5	The heat exchanger network of Alternative 3, HEN-3.....	58
Figure 4.6	The heat exchanger network of Alternative 4, HEN-4.....	59
Figure 4.7	The heat exchanger network of Alternative 5, HEN-5.....	61
Figure 4.8	The heat exchanger network of Alternative 6, HEN-6.....	62
Figure 4.9	The heat exchanger network of Alternative 7, HEN-7.....	64
Figure 4.10	The heat exchanger network of Alternative 8, HEN-8.....	66
Figure 4.11	The Process Flowchart for Alternative 1.....	68
Figure 4.12	The disturbance load propagation for the network of Alternative 1.....	68
Figure 4.13	The Process Flowchart for Alternative 2.....	69
Figure 4.14	The disturbance load propagation for the network of Alternative 2.....	69

	page
Figure 4.15 The Process Flowchart for Alternative 3.....	70
Figure 4.16 The disturbance load propagation for the network of Alternative 3.....	70
Figure 4.17 The Process Flowchart for Alternative 4.....	71
Figure 4.18 The disturbance load propagation for the network of Alternative 4.....	71
Figure 4.19 The Process Flowchart for Alternative 5.....	72
Figure 4.20 The disturbance load propagation for the network of Alternative 5.....	72
Figure 4.21 The Process Flowchart for Alternative 6.....	73
Figure 4.22 The disturbance load propagation for the network of Alternative 6.....	73
Figure 4.23 The Process Flowchart for Alternative 7.....	74
Figure 4.24 The disturbance load propagation for the network of Alternative 7.....	74
Figure 4.25 The Process Flowchart for Alternative 8.....	75
Figure 4.26 The disturbance load propagation for the network of Alternative 8.....	75
Figure 5.1 Application of the control structure 1 (CS1) to the TEP process (Base Case).....	89
Figure 5.2 Application of the control structure 2 (CS2) to the TEP process (Base Case).....	90
Figure 5.3 Application of the control structure 3 (CS3) to the TEP process (Base Case).....	91
Figure 5.4 Application of the control structure 1 (CS1) to the TEP process alternative 1 (Alt1).....	93
Figure 5.5 Application of the control structure 2 (CS2) to the TEP process alternative 1 (Alt1).....	94
Figure 5.6 Application of the control structure 3 (CS3) to the TEP	

	page
process alternative 1 (Alt1).....	95
Figure 5.7 Application of the control structure 1 (CS1) to the TEP process alternative 2 (Alt2).....	97
Figure 5.8 Application of the control structure 2 (CS2) to the TEP process alternative 2 (Alt2).....	98
Figure 5.9 Application of the control structure 3 (CS3) to the TEP process alternative 2 (Alt2).....	99
Figure 5.10 Application of the control structure 1 (CS1) to the TEP process alternative 3 (Alt3).....	101
Figure 5.11 Application of the control structure 2 (CS3) to the TEP process alternative 3 (Alt3).....	102
Figure 5.12 Application of the control structure 3 (CS3) to the TEP process alternative 3 (Alt3).....	103
Figure 5.13 Application of the control structure 1 (CS1) to the TEP process alternative 4 (Alt4).....	105
Figure 5.14 Application of the control structure 2 (CS2) to the TEP process alternative 4 (Alt4).....	106
Figure 5.15 Application of the control structure 3 (CS3) to the TEP process alternative 4 (Alt4).....	107
Figure 5.16 Application of the control structure 1 (CS1) to the TEP process alternative 5 (Alt5).....	109
Figure 5.17 Application of the control structure 2 (CS2) to the TEP process alternative 5 (Alt5).....	110
Figure 5.18 Application of the control structure 3 (CS3) to the TEP process alternative 5 (Alt5).....	111
Figure 5.19 Application of the control structure 1 (CS1) to the TEP process alternative 6 (Alt6).....	113
Figure 5.20 Application of the control structure 2 (CS2) to the TEP process alternative 6 (Alt6).....	114

	page
Figure 5.21 Application of the control structure 3 (CS3) to the TEP process alternative 6 (Alt6).....	115
Figure 5.22 Application of the control structure 1 (CS1) to the TEP process alternative 7 (Alt7).....	117
Figure 5.23 Application of the control structure 1 (CS1) to the TEP process alternative 7 (Alt7).....	118
Figure 5.24 Application of the control structure 1 (CS1) to the TEP process alternative 7 (Alt7).....	119
Figure 5.25 Application of the control structure 1 (CS1) to the TEP process alternative 8 (Alt8).....	121
Figure 5.26 Application of the control structure 2 (CS2) to the TEP process alternative 8 (Alt8).....	122
Figure 5.27 Application of the control structure 3 (CS3) to the TEP process alternative 8 (Alt8).....	123
Figure 5.28 Dynamic responses of the natural gas expander plant (Basecase) to a change in natural gas feed temperature: CS1.....	127
Figure 5.29 Dynamic responses of the natural gas expander plant (Basecase) to a change in natural gas feed temperature: CS2.....	128
Figure 5.30 Dynamic responses of the natural gas expander plant (Basecase) to a change in natural gas feed temperature: CS3.....	129
Figure 5.31 Dynamic responses of the natural gas expander plant (Basecase) to a change in natural gas feed flow rate: CS1..	130
Figure 5.32 Dynamic responses of the natural gas expander plant (Basecase) to a change in natural gas feed flow rate: CS2..	131
Figure 5.33 Dynamic responses of the natural gas expander plant (Basecase) to a change in natural gas feed flow rate: CS3..	132

	page
Figure 5.34 Dynamic responses of the natural gas expander plant (Alt1) to a change in natural gas feed temperature: CS1....	137
Figure 5.35 Dynamic responses of the natural gas expander plant (Alt1) to a change in natural gas feed temperature: CS2....	138
Figure 5.36 Dynamic responses of the natural gas expander plant (Alt1) to a change in natural gas feed temperature: CS3....	139
Figure 5.37 Dynamic responses of the natural gas expander plant (Alt1) to a change in natural gas feed flow rate: CS1.....	140
Figure 5.38 Dynamic responses of the natural gas expander plant (Alt1) to a change in natural gas feed flow rate: CS2.....	141
Figure 5.39 Dynamic responses of the natural gas expander plant (Alt1) to a change in natural gas feed flow rate: CS3.....	142
Figure 5.40 Dynamic responses of the natural gas expander plant (Alt2) to a change in natural gas feed temperature: CS1....	143
Figure 5.41 Dynamic responses of the natural gas expander plant (Alt2) to a change in natural gas feed temperature: CS2....	144
Figure 5.42 Dynamic responses of the natural gas expander plant (Alt2) to a change in natural gas feed temperature: CS3....	145
Figure 5.43 Dynamic responses of the natural gas expander plant (Alt2) to a change in natural gas feed flow rate: CS1.....	146
Figure 5.44 Dynamic responses of the natural gas expander plant (Alt2) to a change in natural gas feed flow rate: CS2.....	147
Figure 5.45 Dynamic responses of the natural gas expander plant (Alt2) to a change in natural gas feed flow rate: CS3.....	148
Figure 5.46 Dynamic responses of the natural gas expander plant (Alt3) to a change in natural gas feed temperature: CS1....	153
Figure 5.47 Dynamic responses of the natural gas expander plant (Alt3) to a change in natural gas feed temperature: CS2....	154
Figure 5.48 Dynamic responses of the natural gas expander plant	

	page
	(Alt3) to a change in natural gas feed temperature: CS3.... 155
Figure 5.49	Dynamic responses of the natural gas expander plant
	(Alt3) to a change in natural gas feed flow rate: CS1..... 156
Figure 5.50	Dynamic responses of the natural gas expander plant
	(Alt3) to a change in natural gas feed flow rate: CS2..... 157
Figure 5.51	Dynamic responses of the natural gas expander plant
	(Alt3) to a change in natural gas feed flow rate: CS3..... 158
Figure 5.52	Dynamic responses of the natural gas expander plant
	(Alt4) to a change in natural gas feed temperature: CS1.... 159
Figure 5.53	Dynamic responses of the natural gas expander plant
	(Alt4) to a change in natural gas feed temperature: CS2.... 160
Figure 5.54	Dynamic responses of the natural gas expander plant
	(Alt4) to a change in natural gas feed temperature: CS3.... 161
Figure 5.55	Dynamic responses of the natural gas expander plant
	(Alt4) to a change in natural gas feed flow rate: CS1..... 162
Figure 5.56	Dynamic responses of the natural gas expander plant
	(Alt4) to a change in natural gas feed flow rate: CS2..... 163
Figure 5.57	Dynamic responses of the natural gas expander plant
	(Alt4) to a change in natural gas feed flow rate: CS3..... 164
Figure 5.58	Dynamic responses of the natural gas expander plant
	(Alt5) to a change in natural gas feed temperature: CS1.... 169
Figure 5.59	Dynamic responses of the natural gas expander plant
	(Alt5) to a change in natural gas feed temperature: CS2.... 170
Figure 5.60	Dynamic responses of the natural gas expander plant
	(Alt5) to a change in natural gas feed temperature: CS3.... 171
Figure 5.61	Dynamic responses of the natural gas expander plant
	(Alt5) to a change in natural gas feed flow rate: CS1..... 172
Figure 5.62	Dynamic responses of the natural gas expander plant
	(Alt5) to a change in natural gas feed flow rate: CS2..... 173

	page
Figure 5.63 Dynamic responses of the natural gas expander plant (Alt5) to a change in natural gas feed flow rate: CS3.....	174
Figure 5.64 Dynamic responses of the natural gas expander plant (Alt6) to a change in natural gas feed temperature: CS1....	175
Figure 5.65 Dynamic responses of the natural gas expander plant (Alt6) to a change in natural gas feed temperature: CS2....	176
Figure 5.66 Dynamic responses of the natural gas expander plant (Alt6) to a change in natural gas feed temperature: CS3....	177
Figure 5.67 Dynamic responses of the natural gas expander plant (Alt6) to a change in natural gas feed flow rate: CS1.....	178
Figure 5.68 Dynamic responses of the natural gas expander plant (Alt6) to a change in natural gas feed flow rate: CS2.....	179
Figure 5.69 Dynamic responses of the natural gas expander plant (Alt6) to a change in natural gas feed flow rate: CS3.....	180
Figure 5.70 Dynamic responses of the natural gas expander plant (Alt7) to a change in natural gas feed temperature: CS1....	185
Figure 5.71 Dynamic responses of the natural gas expander plant (Alt7) to a change in natural gas feed temperature: CS2....	186
Figure 5.72 Dynamic responses of the natural gas expander plant (Alt7) to a change in natural gas feed temperature: CS3....	187
Figure 5.73 Dynamic responses of the natural gas expander plant (Alt7) to a change in natural gas feed flow rate: CS1.....	188
Figure 5.74 Dynamic responses of the natural gas expander plant (Alt7) to a change in natural gas feed flow rate: CS2.....	189
Figure 5.75 Dynamic responses of the natural gas expander plant (Alt7) to a change in natural gas feed flow rate: CS3.....	190
Figure 5.76 Dynamic responses of the natural gas expander plant (Alt8) to a change in natural gas feed temperature: CS1....	191
Figure 5.77 Dynamic responses of the natural gas expander plant	

	page
(Alt8) to a change in natural gas feed temperature: CS2....	192
Figure 5.78 Dynamic responses of the natural gas expander plant	
(Alt8) to a change in natural gas feed temperature: CS3....	193
Figure 5.79 Dynamic responses of the natural gas expander plant	
(Alt8) to a change in natural gas feed flow rate: CS1.....	194
Figure 5.80 Dynamic responses of the natural gas expander plant	
(Alt8) to a change in natural gas feed flow rate: CS2.....	195
Figure 5.81 Dynamic responses of the natural gas expander plant	
(Alt8) to a change in natural gas feed flow rate: CS3.....	196
Figure A.1 Input and Output from Relay-Feedback Test.....	211

CHAPTER I

INTRODUCTION

This chapter is an introduction of this research. It consists of importance and reasons for the research, research objectives, scopes of the research, contributions of the research and research procedures.

1.1 Importance and Reasons for the Research

An important problem in process control is to develop effective control structures for complex whole plants. Over the last few decades, control analysis and control system design for chemical and petroleum processes have traditionally followed the unit operation approach. First, all of the control loops were established individually for each unit or piece of the equipment in the plant. Then the pieces were combined together into an entire plant. This method works well when the processes are in cascade form (i.e. without material and energy recycles) or large surge tanks are installed for processes with recycle streams to isolate the individual units.

Nowadays, the tendency of energy demands is rapidly increasing. With high fuel prices and the possibility of supplies in the years ahead, the importance of developing systems to use energy more efficiently is apparent. One of the major components in the chemical processing is the heat exchanger network, because it determines to a large extent the net energy consumption of the process. Tremendous efforts have been expanded to establish a series of systematic approaches toward conserving energy and also minimizing losses in the process industries. Moreover, industries are very competitive both in quality and cost of production. Therefore, the production process should have high quality and high efficiency. The process should always operate under the design condition, use little energy, low waste production and meet the required specification of the products.

In general, most industrial processes contain a complex flowsheet with several recycle streams, heat integration, and many different unit operations. The economic can be improved by introducing recycle streams and energy integration into process. However, the recycle streams and energy integration introduce a feedback of material and energy among units upstream and downstream. They also interconnect separate unit operations and create a path for disturbance propagation. Therefore, strategies for plantwide control are required to operate an entire plant safely and achieve its design objectives. Essentially, the plantwide control problem is how to develop the control loops need to operate an entire process and achieve its design objectives. The problem is quite large and complex. There are a combinatorial number of possible choices and alternative strategies to control and manage the disturbance load entering the process.

The natural gas expander plant consists of a low-temperature separator (LTS), vapor-liquid separator (VLS), turbo-expander, reboiled absorber and heat exchanger network, which the complexity of this plant is the interactions of the HEN with the expander part of the plant. Efficient heat integration in the HEN, which is used to pre-cool the feed to the LTS, is of major importance in the design of turbo-expander plants (TEPs). Therefore, this process will be used to study and design heat exchanger networks and control structures in the process with heat propagation method and plantwide process control theory.

In this work, the main objective is to design heat exchanger networks and control structures of the natural gas expander plant. The heat exchanger networks will be designed using disturbance load propagation method (Wongsri, 1990) and the plantwide control structure will be designed using Luyben heuristic design method (1999) and fixture point theorem (Wongsri, 2008). The performance of the heat exchanger network design and their control structures are evaluated via simulation using HYSYS.

1.2 Research Objectives

The objectives of this work are listed below:

1. To design heat exchanger networks (HEN) of the natural gas turbo-expander plant (TEP) using disturbance load propagation method (Wongsri, 1990).
2. To design control structure for a HEN-integrated natural gas expander plant using plantwide control structure (Luyben, 1998).
3. To assess performance of the designed control structures for a HEN- integrated natural gas expander plant.

1.3 Scopes of the Research

The objectives of this work are listed below:

1. Simulation of the natural-gas turbo-expander plant (TEP) operating under ethane-recovery mode is performed by using a commercial process simulator - HYSYS.
2. Description and data of the natural gas turbo-expander plant is obtained from U. Akman and Alp Er S. Konukman, 2005.
3. Plantwide control structures for a HEN-integrated natural gas expander plant are designed using Luyben's heuristics method.
4. The eight heat exchanger networks and three control structures in the natural gas expander plant are designed.

1.4 Contributions of the Research

The contributions of this work are as follows:

The new heat exchanger network and control structures of the natural gas turbo-expander plant are designed and compared with the work given by U. Akman and Alp Er S. Konukman.

1.5 Research Procedures

The procedures of this work are as follows:

1. Study natural gas expander plant and concerned information.
2. Study disturbance load propagation method and plantwide process control theory.
3. Design heat exchanger networks of the natural gas expander plant.
4. Design disturbance load propagation for heat exchanger networks.
5. Simulate the steady state of the natural gas expander plant.
6. Design control structure of the natural gas expander plant.
7. Simulate the dynamic of the natural gas expander plant with heat exchanger network and control structure design.
8. Evaluate the dynamic performance of the designed control structures.
9. Analyze the design and simulation results.
10. Conclude the thesis.

1.6 Research Contents

This thesis is divided into six chapters:

Chapter I is an introduction to this research. This chapter consists of importance and reasons for research, research objectives, scopes of research, contributions of research and research procedures.

Chapter II reviews the work carried out on heat exchanger networks design, heat integrated processes and plantwide control design.

Chapter III covers some background information of heat exchanger network design, disturbance transfer technique plantwide (Wongsri, 1990) and theory concerning with plantwide control.

Chapter IV describes the process description and the design of heat exchanger networks for the natural gas expander plant.

Chapter V describes the design of plantwide control structures and dynamic simulation results.

Chapter VI presents the conclusion of this research and makes the recommendations for future work.

This is follow by:

References

Appendix A: Tuning of Control Structures

Appendix B: Process and Equipment Data of Natural Gas Expander Plant

Appendix C: Fixture Point Theorem Data

CHAPTER II

LITERATURE REVIEW

Our purpose of this chapter is to present a review of the previous works on the heat exchanger network (HEN) and plantwide control design.

2.1 Heat Exchanger Networks (HENs)

Energy conservation is important in process design. The fundamental result for the use of energy integration is to improve the thermodynamic efficiency of the process. This translates into a reduction in utility cost.

Linhoff and Hindmarsh (1983) presented a novel method for the design of HEN. The method is the first to combine sufficient simplicity to be used by hand with near certainty to identify "best" designs, even for large problems. Best design features the highest degree of energy recovery possible with a given number of capital items. Moreover, they feature network patterns required for good controllability, plant layout, intrinsic safety, etc. Typically, 20-30 percent energy savings, coupled with capital saving, can be realized in state of the art flowsheets by improved HEN design. The task involves the placement of process and utility heat exchangers to heat and cool process streams from specified supply to specified target temperatures.

Linhoff, Dunford and Smith (1983) studied heat integration of distillation columns into overall process. This study reveals that good integration between distillation and the overall process can result in column operating at effectively zero utility cost. Generally, the good integration is when the integration as column not crossing heat recovery pinches of the process and either the reboiler or the condenser being integrated with the process. If these criteria can be met, energy cost for distillation can effectively be zero.

Saboo and Morari (1983) classified flexible HENs into two classes according to the kind and magnitude of disturbances that effect the pinch location. For the temperature variation, they show that if the MER can be expressed explicitly as a function of stream supply and target conditions the problem belongs to Class I, i.e. the case that small variations in inlet temperatures do not affect the pinch temperature location. If an explicit function for the minimum utility requirement valid over the whole disturbance range does not exist, the problem is of Class II, i.e. the case that large changes in inlet temperature of flowrate variations cause the discrete changes in pinch temperature locations.

Marselle et al. (1982) addressed the problem of synthesizing heat recovery networks, where the inlet temperatures vary within given ranges and presented the design procedure for a flexible HEN by finding the optimal network structures for four selected extreme operating conditions separately. The specified worst cases of operating conditions are the maximum heating, the maximum cooling, the maximum total exchange and the minimum total exchange. The network configurations of each worst condition are generated and combined by a designer to obtain the final design. The strategy is to derive similar design in order to have as many common units as possible in order to minimize number of units.

Linnhoff and Kotjabasakis (1984) developed a design procedure for operable HENs by inspection and using the concept of downstream paths, i.e. the paths that connect the disturbed variables downstream to the controlled variables. They generated HEN design alternatives by the pinch method for the nominal operating condition. Then, the alternative designs are inspected for the effects of disturbances on the controlled variables and they are removed by breaking the troublesome downstream paths. Path breaking can be done by relocating and/or removing exchangers. If this procedure is not feasible, control action is inserted into the structure.

Saboo and Morari (1984) proposed the corner point theorem which states

that for temperature variation only, if a network allows MER without violating ΔT_{min} at MER corner points, then the network is structurally resilient or flexible. This is the case where the constraint is convex, so examining the vertices of the polyhedron is sufficient. This procedure again can only apply to restricted classes of HEN problem. Their design procedure is similar to Marselle et al. (1982), but using two extreme cases to develop the network structure. The strategy for both procedures is finding similar optional network structures for the extreme cases and the base case design in order that they may be easily merged and not have too many units. Two extreme cases are:

1. When all streams enter at their maximum inlet temperatures and the heat capacity flowrates of hot streams are maximal and those of cold streams minimal. This is the case of maximum cooling.
2. When all streams enter at their minimum inlet temperatures and the heat capacity flowrates of hot streams are minimal and those of cold streams maximal. This is an opposite case the above one and in this case maximum heating is required.

The 'base' design is then generated by using an optimization technique and the final design is obtained by combining these designs. A test for resiliency (calculating, RI) is required. If the design is not feasible a modification is done by attempting to reduce ΔT_{min} and if not successful, a new heat exchanger will added or some heat exchangers are located. If the modified network is still not resilient, synthesize network structures at all corner points where the current design is not feasible. The new structures should be as similar to the current design as possible. The new design is obtained by superimposing the current structure and the new structures. The unneeded heat exchangers are inspected and removed.

Floudas and Grossmann (1987) presented a synthesis procedure for resilient HENs. Their multiperiod operation transshipment model is used to find a match structure for selected design points. The design obtained for feasibility at the

match level. If it is not feasible, the critical point is added as an additional operating point and the problem is reformulated and solved. If the match network is feasible then the multiperiod superstructure is derived and formulated as an NLP problem to find a minimum unit solution.

Calandranis and Stephanopoulos (1988) proposed a new approach to address the following problems: design the configuration of control loops in a network of heat exchangers and sequence the control action of the loops, to accommodate set point changes and reject load disturbances. The approach proposed exploits the structure characteristics of a HEN by identifying routes through the HEN structure that can allocate load (disturbances, or set point changes) to available sinks (external coolers or heaters). They also discussed several design issues such as the placement of bypass lines and the restrictions imposed by the existence of a process pinch. An online, real-time planning of control actions is the essence of implementation strategies generated by an expert controller, which selects path through the HEN is to be used for each entering disturbance or set point change, and what loops should be activated (and in what sequence) to carry the associated load (disturbance or set point change) to a utility unit.

Colberg (1989) suggested that flexibility should deal with planned, desirable changes that often have a discrete set of values. Whereas resilience deals with unplanned, undesirable changes which are naturally continuous values. Thus a flexibility problem is a 'multiple period' type of problem. A resilience problem should be a problem with a continuous range of operating conditions in the neighborhood of nominal operating points.

Wongsri (1990) studied a resilient HENs design. He presented a simple but effective systematic synthesis procedure for the design of resilient HEN. His heuristic design procedure is used to design or synthesize HENs with pre-specified resiliency. It used physical and heuristic knowledge in finding resilient HEN structures. The design must not only feature minimum cost, but must also be able cope

with fluctuation or changes in operating conditions. The ability of a HEN to tolerate unwanted changes is called resiliency. It should be noted that the ability of a HEN to tolerate wanted changes is called flexibility. A resilient HEN synthesis procedure was developed based on the match pattern design and a physical understanding of the disturbances propagation concept. The disturbance load propagation technique was developed from the shift approach and was used in a systematic synthesis method. The design condition was selected to be the minimum heat load condition for easy accounting and interpretation. This is a condition where all process streams are at their minimum heat loads, e.g. the input temperatures of hot streams are at the lowest and those of cold streams are at the highest.

Ploypaisansang (2003) presented to redesign six alternatives for HDA process to be the resiliency networks for maintain the target temperature and also achieve maximum energy recovery (MER). The best resilient network is selected by to trade-off between cost and resiliency. The auxiliary unit should be added in the network for cope safely with the variations and easy to design control structure to the network.

Akman and Konukman (2005) investigated steady-state operability and flexibility issues of a HEN with rigorous simulations using the process flowsheet simulator HYSYS for a HEN-integrated natural gas expander plant (TEP) operating under ethane-recovery mode. Bypass streams and stream splits in the HEN, selected after a sensitivity analysis, were used to increase flexibility and disturbance-rejection ability of the TEP. The emphasis was given to the assessment of flexibility of the process in maintaining desired level of cooling in the HEN, and desired levels of ethane recovery and methane rejection under temperature and pressure disturbance in the natural-gas feed stream. The heat-exchanger bypasses and split fraction as the manipulated variables were able to control the ethane recovery at its set point for wide range of natural-gas feed-stream disturbances.

Wongsri and Sae-Leaw (2006) proposed the guide line to design workable of highly heat integrated process with minimum auxiliary reboiler. It starts with specifying the disturbances and their magnitudes, and then designing the resilient heat exchanger network is designed at the worst case condition as the minimum heat supply and maximum heat demand condition. There considered only one worst case to find the number of minimum auxiliary heating unit and the heat path way for disturbance load at worst case condition is no considering dynamic maximum energy recovery (DMER).

2.2 Design and Control of Integrated Plants

Handogo and Luyben (1987) studied the dynamics and control of a heat-integrated reactor/column system. An exothermic reactor was the heat source, and a distillation column reboiler was the heat sink. Two types of heat-integration systems were examined: indirect and direct heat integration. Both indirect and direct heat integration systems are found in industry. In the indirect heat-integration system, steam generation was used as the heating medium for the reboiler. The direct heat integration system used the reactor fluid to directly heat the column reboiler. The indirect heat-integration system was found to have several advantages over the direct heat integration system in terms of its dynamic performance. Both systems were operable for both large and small temperature differences between the reactor and column base.

Luyben and Luyben (1995) examines the plantwide design and control of a complex process. The plant contains two reaction steps, three distillation columns, two recycle streams, and six chemical components. Two methods, a heuristic design procedure and a nonlinear optimization, have been used to determine an approximate economically optimal steady-state design. The designs differ substantially in terms of the purities and flow rates of the recycle streams. The total annual cost of the nonlinear optimization design is about 20 percent

less than the cost of the heuristic design. An analysis has also been done to examine the sensitivity to design parameters and specifications. Two effect control strategies have been developed using guidelines from previous plantwide control studies; both require reactor composition control as well as flow control of a stream somewhere in each recycle loop. Several alternative control strategies that might initially have seemed obvious do not work.

Jones and Wilson (1997) considered the range ability of flows in the bypass line of heat exchanger through interesting heat exchanger problems. Difficulty is immediately encountered when considering heat exchanger between two process streams; changing the flow rate of one will certainly affect the exit temperature of the other. Unfortunately, interfering with a process stream flow rate immediately upsets the plant mass balance, which is undesirable. The difficulty is overcome by using a bypass that does not affect the total flow rate but changes the proportion actually passing through the heat exchanger and hence the heat transfer. Good engineering practice would maintain a minimum flow rate of 5-10 percent through the bypass. This bypass is expected to be able to handle disturbances.

Luyben, Tyreus and Luyben (1997) presented a general heuristic design procedure. Their procedure generated an effective plantwide control structure for an entire complex process flowsheet and not simply individual 17 units. The nine steps of the proposed procedure center around the fundamental principles of plantwide control: energy management, production rate, product quality, operational, environmental and safety constraints, liquid-level and gas-pressure inventories, makeup of reactants, component balances and economic or process optimization. Application of the procedure was illustrated with three industrial examples: the vinyl acetate monomer process, Eastman process and HDA process. The procedure produced a workable plantwide control strategy for a given process design. The control system was tested on a dynamic model built with TMODS, Dupont's in-house simulator.

After that, Luyben (2000) studied the process had the exothermic, irreversible, gas-phase reaction $A + B \rightarrow C$ occurring in an adiabatic tubular reactor. A gas recycle returns unconverted reactants from the separation section. Four alternative plantwide control structures for achieving reactor exit temperature control had been compared. Manipulation of reactor inlet temperature appeared to be the least attractive scheme. Manipulation of recycle flow rate gave the best control but may be undesirable in some system because of compressor limitations. The on-demand structure provided effective control in the face of feed composition disturbances.

Wongsri and Kietawarin (2002) presented a comparison among 3 control structure designs for reduced effect from disturbances that caused production rate change of HDA process. The first control scheme measured toluene flow rate in the process and adjusted the fresh toluene feed rate accordingly. The second was modified from the first scheme by added a cooling unit to control the outlet temperature from the reactor. In the third scheme, a ratio was introduced to the second control scheme for controlling the ratio of hydrogen and toluene within the process. These three control structures was compared with reference on plantwide process control book, Luyben (1999), the result was performance of these structure higher than reference.

Wongsri and Hermawan (2004) studied the control strategies for energy-integrated HDA plant (i.e. alternatives 1 and 6) based on the heat pathway heuristics (HPH), i.e. selecting an appropriate heat pathway to carry associated load to a utility unit, so that the dynamic MER can be achieved with some trade-off. In they work, a selective controller with low selector switch (LSS) is employed to select an appropriate heat pathway through the network. The new control structure with the LSS has been applied in the HDA plant. The study reveals that, by selecting an appropriate heat pathway through the network, the utility consumptions can be reduced according to the input heat load disturbances; hence the dynamic MER can be achieved.

Kunajitpimol (2006) presented the resilient heat exchanger networks to achieve dynamic maximum energy recovery, plantwide control structures, and control strategies are designed for Butane Isomerization plant. The control difficulties associated with heat integration are solved by adding auxiliary utilities which is kept minimal. Four alternatives of heat exchanger networks (HEN) designs of the Butane Isomerization plant are proposed. They used the heat from the reactor effluent stream to provide the heat for the column reboiler. The energy saved is 24.88 percent from the design without heat integration, but the additional capital is 0.67 percent due to adding of a process to process exchanger and an auxiliary utility exchanger to the process.



ศูนย์วิทยทรัพยากร
จุฬาลงกรณ์มหาวิทยาลัย

CHAPTER III

THEORY

This chapter is aimed to summarize heuristic approach from the previous researches and this approach in heat pathway view point which was developed by Wongsri and Hermawan (2004). Furthermore, we propose the plantwide control involving the system and strategies required to control entire plant consisting of many interconnected unit operations.

3.1 Basic Knowledge for Pinch Technology

3.1.1 Pinch Technology

Pinch technology has been developed for more than two decades and now provides a systematic methodology for analysis chemical processes and surrounding utility systems. The concept was first developed by two independent research groups (Flower and Linnhoff, 1978; Umeda et al., 1979), based on an applied thermodynamics point of view.

3.1.2 Basic Pinch Analysis Concept

The pinch analysis concept is originated to design the heat recovery in network for a specified design task. Starting with do calculate heat and material balance of the process obtained after the core process, i.e. reaction and separation system, has been designed. By using thermal data from the process, we can set the target for energy saving prior to the design of the heat exchanger networks. The necessary thermal data is source, target temperature and heat capacity flow rate for each stream as shown in Table 3.1.

Table 3.1: Thermal data for process streams (Linnhoff and Hindmarsh, 1983).

Stream No.	Stream type	Start Temperature (T_s), $^{\circ}C$	Target Temperature (T_t), $^{\circ}C$	Heat capacity flow rate (CP), $kW/^{\circ}C$
1	Hot	150	60	2
2	Hot	90	60	8
3	Cold	20	125	2.5
4	Cold	25	100	3

Here the hot streams are referred to the streams that required cooling, i.e. the source temperature is higher than that of the target. While the cold streams are referred to those required heating, i.e. the target temperature is higher than the supply. Heat Capacity flow rate is defined as the multiple between specific heat capacity and mass flow rate as shown below.

$$CP = C_p * F \quad (3.1)$$

where:

CP = heat capacity flow rate ($kW/^{\circ}C$)

Cp = Specific heat capacity of the stream ($kJ/^{\circ}C.kg$)

F = mass flow rate of the stream (kg/s)

The data used here is based on the assumption that the heat capacity flow rate is constant. In practice, this assumption is valid because every streams with or without phase change can easily be described in terms of linearization temperature-enthalpy data (i.e. CP is constant). The location of pinch and the minimum utility requirement can be calculated by using the problem table algorithm (Linnhoff and Flower, 1979) for a specified minimum temperature different, ΔT_{min} . In the case of $\Delta T_{min} = 20^{\circ}C$, the results obtained from this method are shown in Table 3.2.

Table 3.2: The problem table for data given in Table 3.1

W				T hot (°C)	T cold (°C)	ΣW (kW/°C)	ΔT (°C)	Required Heat (kW)	Interval (kW)	Cascade Heat (kW)	Sum Interval (kW)
0	0	0	0	150	130	0		Qh		-105	
2	0	0	0	145	125	2	5	107.5	10	2.5	10
2	0	2.5	0	120	100	-0.5	25	117.5	-12.5	12.5	-2.5
2	0	2.5	3	90	70	-3.5	30	105	-105	0	-107.5
2	8	2.5	3	60	40	4.5	30	0	135	-105	27.5
0	0	2.5	3	45	25	-5.5	15	135	-82.5	30	-55
0	0	2.5	0	40	20	-2.5	5	52.5	-12.5	-52.5	-67.5
										Qc	

The pinch separates the problem into 2 thermodynamic regions, namely, hot end and cold end. The hot end is the region comprising all streams or part of stream above the pinch temperature. Only hot utility is required in this region but not cold utility. In contrast to the hot end, the cold end is the region comprising all streams or part of stream below the pinch temperature and only cold utility is instead desired regardless the hot utility. It is important to note that there is no heat transfer across the pinch therefore the minimum utility requirement is achieved.

Additionally, Saboo and Morari (1983) classified flexible HENs into two classes according to the kind and magnitude of disturbances that affect the pinch location. For the temperature variation, they show that if the MER can be expressed explicitly as a function of the stream supply and target conditions the problem belongs to Class I, i.e. the case where small variations in inlet temperatures do not affect the pinch temperature location. If the explicit function for the minimum utility requirement valid over the whole disturbance range does not exist, the problem is of Class II, i.e. the case where large changes in inlet temperatures or flow rate variations cause the discrete changes in pinch temperature locations.

3.2 Heat Exchanger networks (HENs)

It is generally accepted that an optimal network must feature a minimum number of units that reflects on a capital cost and minimum utility consumption that reflects on operating costs. A good engineering design must exhibit minimum capital and operating costs. For Heat Exchanger Network (HEN) synthesis, other features that are usually considered in design are operability, reliability, safety, etc. in recent years the attention in HEN synthesis has been focused on the operability features of a HEN, e.g. the ability of a HEN to tolerate unwanted changes in operating conditions. It has been learned that considering only a cost objective in synthesis may lead to a worse network, i.e. a minimum cost network may not be operable at some neighboring operating conditions. The design must not only feature minimum cost, but also be able cope with a fluctuation or changes in operating conditions. The ability of a HEN to tolerate unwanted changes is called *resiliency*. It should be noted that the ability of a HEN to tolerate wanted changes is called *flexibility*.

The resiliency property of a design becomes an important feature to be accounted for when the extent of integration of a design introduces significant interactions among process components. The energy integration of a HEN generates a quite complex interaction of process streams, despite the fact that transfer of heat from hot to cold process streams is the only activity of the network. The goal of a network is to deliver the process streams to their target temperatures by using most of their heating and cooling availability and a minimum of heating and cooling utilities. The process streams are coupled through a net of heat exchangers. Changing in conditions of one stream in the network may affect the performances of many heat exchanges and the conditions of several process streams. Since resiliency is a property of a network structure.

3.2.1 Definition of HEN Resiliency

In the literature, resiliency and flexibility have been used synonymously to describe the property of HEN to satisfactorily handle variations in operating conditions. These two terms have difference in meaning.

The resiliency of a HEN is defined as the ability of a network to tolerate or remain feasible for disturbances in operating conditions (e.g. fluctuations of input temperatures, heat capacity flowrate, etc.). As mentioned before, HEN flexibility is closed in meaning to HEN resiliency, but HEN flexibility usually refers to the wanted changes of process conditions, e.g. different nominal operating conditions, different feed stocks, etc. That is, HEN flexibility refers to the preservation of satisfactory performance despite varying conditions, while flexibility is the capability to handle alternate (desirable) operating conditions.

A further distinction between resiliency and flexibility is suggested by Colberg et al. (1989). Flexibility deals with planned, desirable changes that often have a discrete set of values; resilience deal with unplanned, undesirable changes that naturally are continuous values. Thus a flexibility is a 'multiple period' type of problem. A resilience problem should be a problem with a continuous range of operating conditions in the neighborhood of nominal operating points.

In order to make Alternative 6 of HDA plant more economically appealing, the minimum number of auxiliary utilities is identified using the proposed design scheme adapted from Wongsri's RHEN (for resilient heat exchanger network) design method.

3.2.2 Heuristics for HEN Synthesis

Several HEN matching rules with minimum energy and investment costs have been presented (Masso and Rudd, 1969, Ponton and Donalson, 1974 Rathore and Powers, 1975, Linnhoff and Hindmarsh, 1983, Jezowski and Hahne1986, Huang, Metha and fan, 1988, etc.),

The following are heuristics from the literature classified according to the design criteria

The heuristics to minimize the capital cost (the number of heat exchangers):

Heuristic C1. To generate a network featuring the minimum number of heat exchanger units, let each match eliminate at least one of the two streams; a tick-off rule (Hohmann, 1971).

Heuristic C2. Prefer the matches that will leave a residual stream at its cold end for a heating problem, or its hot end for a cooling problem. A match of this type will feature the maximum temperature difference.

Heuristic C3. Prefer matching large heat load streams together. The significance of this rule is that the control problem (a capital cost) of a match of this type (whether it is implemented by one or many heat exchangers) should be less than that of heating or cooling a large stream with many small streams.

The heuristics to minimize the energy cost (the minimum utility requirement):

Heuristic E1. Divide the problem at the pinch into subproblems, one a heat sink (heating subproblem or hot end problem) and the other a heat source (cooling subproblem or cold end problem), and solve them separately (Linnhoff and Hindmarsh, 1983).

Heuristic E2. Do not transfer heat across the pinch.

Heuristic E3. Do not cool above the pinch.

Heuristic E4. Do not heat below the pinch.

The laws of thermodynamics:

Heuristic T1. In a heating problem, if a supply temperature of a cold stream is less than a target temperature of a hot stream by T_{min} or more and the heat capacity flow rate of a hot stream is less than or equal to the heat capacity flow rate of a cold stream, the match between these two streams is feasible.

(Immediately above the pinch temperature, the heat capacity flow rate of a cold stream must be greater than or equal to that of a hot stream.)

Heuristic T2. In a cooling problem, if a supply temperature of a hot stream is greater than a target temperature of a cold stream by T_{min} or more and the heat capacity flow rate of a hot stream is greater than equal to the heat capacity flow rate of a cold stream, the match between these two streams is feasible. (Immediately below the pinch temperature, the heat capacity flow rate of a hot stream must be greater than or equal to that of a cold stream.)

Heuristic T3. For a situation different from the above rule, a match feasibility must be determined by checking whether the minimum temperature difference of a match violates the minimum approach, T_{min} , specific by the design.

3.2.3 Math Classification

In order to make use of the heuristics we must classify matches. The following criteria are considered important in this research:

1. Position of a Match. One heuristic prefers a match at the cold end and another prefers a match at the hot end. Pinch heuristics prefers a match at the cold end in a heating subproblem and a match at the hot end in a cooling subproblem. However, there are other possibilities. By using the tick-off heuristic, there are four ways that two streams can match. This leads to the basic four match patterns (Wongsri, 1990).

2. Heat capacity flow rate (between hot and cold stream). See Heuristic T.1 and T.2.

3. Heat Load (between hot and cold streams). The heuristic that concerns heat load state that one must match large heat load hot and cold streams first. This leads to two additional heuristic:

Heuristic N1. For a heating subproblem, a match where the heat load of a cold stream is greater than that of a hot stream should be given higher priority

than the other. The reason is that the net heat load heating subproblem is in deficit. The sum of heat loads of cold streams is greater than of hot streams. The purposed match will likely be part of a solution (Wongsri, 1990).

Heuristic N2. Conversely, we prefer a match where the heat load of a hot stream is greater than that of a cold in a cooling subproblem (Wongsri, 1990).

4. Residual Heat Load. No heuristics for this quantity have thus far appeared in the literature. Two new heuristics are introduced.

For a match in a heating subproblem that satisfies the heat load preference heuristics N.1;

Heuristic N3. We prefer a match where the residual heat load is less than or equal to the minimum heating requirement (Wongsri, 1990).

For a match in a cooling subproblem that satisfies the heat load preference or heuristics N.2;

Heuristic N4. We prefer a match where the residual heat load is less than or equal to the minimum cooling requirement, (Wongsri, 1990).

The reason behind the above two heuristics N3 and N4 is that the residual may be matched to a utility stream. One has the possibility of eliminating two streams at once.

3.2.4 Match Patterns

HEN synthesis is usually considered as a combinatorial matching problem. For a HEN in which a design property is regarded as a network property, or a structural property, we need to look beyond the match level to a higher level where such a property exists, e.g. to a match structure or match pattern. Match patterns are the descriptions of the match configuration of two, and possibly more, process streams and their properties that are thermally connected with heat exchangers. Not only the match description, e.g. heat duty of an exchanger and inlet and outlet temperatures is required but also the position of a match, e.g. upstream or downstream, the magnitude of the residual heat load and the heat capacity flow

rates between a pair of matched streams.

By using the 'tick off rule' there are four match patterns for a pair of hot and cold streams according to the match position and the length (heat load) of streams. The four patterns are considered to the basic match pattern classes. The members of these classes are the patterns where other configurations and properties are specified. The four match pattern classes are simply called A, B, C and D and are shown in Figure 3.4, 3.5, 3.6 and 3.7 respectively. Any eligible match must belong to one of the four match pattern classes.

Definition 3.1 Class A Match Pattern: The heat load of a cold stream is greater than the heat load of a hot stream in a pattern, i.e. the hot stream is totally serviced. The match is positioned at the cold end of the cold stream. The residual heat load is on the hot portion of the cold stream. (See Figure 3.1)

A match of this class is a first type match at cold end position and the heat load of the cold stream is greater than that of the hot stream. This is a upstream match. For a heating subproblem, a Class A match is favored, because it leaves a cold process stream at the hot end (Heuristic N1) and follows the pinch heuristics. (See Table 3.3)

Definition 3.2 Class B Match Pattern: The heat load of a hot stream is greater than the heat load of a cold stream in a pattern, i.e. the cold stream is totally serviced. The match is positioned at the hot end of the hot stream. The residual heat load is on the cold portion of the hot stream. (See Figure 3.2)

A match of this class is a second type match; a hot end match and the heat load of the hot stream is greater than that of the cold stream. This is an upstream match. For a cooling subproblem, a Class B match is favored, because it leaves a hot process stream at the cold end (Heuristic N2) and also follows the pinch heuristics. (See Table 3.3)

Definition 3.3 Class C Match Pattern: The heat load of a hot stream is

greater than the heat load of a cold stream in a pattern, i.e. the cold stream is totally serviced. The match is positioned at the cold end of the hot stream. The residual heat load is on the hot portion of the hot stream. (See Figure 3.3)

A match of this class is a first type match; a cold end match and the heat load of the hot stream is greater than that of the cold stream. This is a downstream match. (See Table 3.4)

Definition 3.4 Class D Match Pattern: The heat load of a cold stream is greater than the heat load of a hot stream in a pattern, i.e. the hot stream is totally serviced. The match is positioned at the hot end of the cold stream. The residual heat load is on the cold portion of the cold stream. (See Figure 3.4)

A match of this class is a second type match; a hot end match and the heat load of the cold stream is greater than that of the hot stream. This is a downstream match. (See Table 3.4)

When the residual heat load in a match pattern is matched to a utility stream, it is closed or completed pattern. Otherwise, it is an open or incomplete pattern. It can be seen that if the heat load of the residual stream is less than the minimum heating or cooling requirement then the chances that the match pattern will be matched to a utility stream is high. So we give a match pattern which its residual less than the minimum heating or cooling requirement a high priority in match pattern.

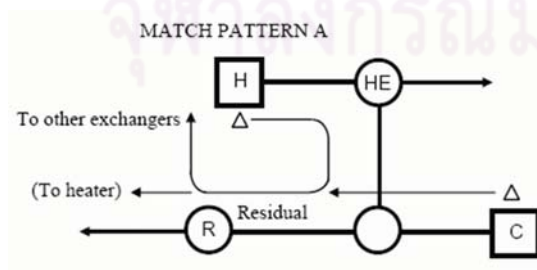

Figure 3.1: Class A Match Pattern.

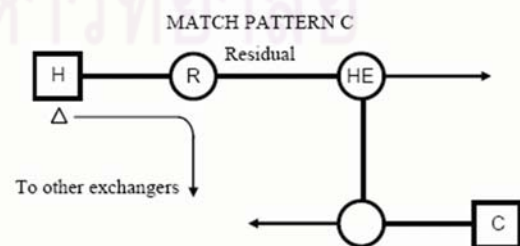

Figure 3.3: Class C Match Pattern

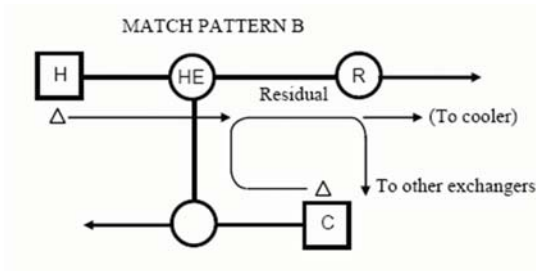

Figure 3.2: Class B Match Pattern.

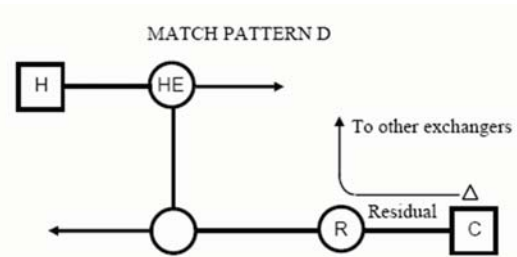

Figure 3.4: Class D Match Pattern

A match of Class A or Class C will leave a residual at the hot end, while a match of Class B or D will leave a residual at the cold end. Heuristics N.3 and N.4 will be use heuristics to further subclassify matches of Class A and B into matches of high priority.

We will make use of Heuristic N.3 and N.4 to further subclassify matches of Class A and B and give the following subclass matches high priorities.

Subclass AH. A match of this subclass is a member of Class A, a heating problem where the residual is less than or equal to the minimum heating requirement. (A letter H in the subclass name denotes that the residual is matched to a heating utility.)

Subclass BK. A match of this subclass is a member of Class B, a cooling problem where the residual is less than or equal to the minimum cooling requirement. (A letter K in the subclass name denotes that the residual is matched to a cooling utility.)

As it might be expected, we give a match of subclasses AH in a heating subproblem and BK in a cooling subproblem the highest priorities. See Table 3.4.

We further discriminate match patterns according to heat capacity flow rate. By following pinch heuristics, in a heating problem, we prefer a match where the heat capacity flowrate of a cold stream is greater than or equal to that of a hot stream. For example, A[H]H is a match in which the heat capacity flowrate

of the cold stream is greater than that of the hot stream and the residual of the cold stream is matched to the heating utility.

Similarly in a cooling problem, we prefer a match where the heat capacity flowrate of the hot stream is greater than or equal to that of the cold stream. For example, B[C]K is a match in which the heat capacity flowrate of the hot stream is greater than that of the cold stream and the residual of the hot stream is matched to the cooling utility.

In summary, the rankings of the match patterns in a heating problem are AH, A[H], B[C], A[C], B[H], C[H], D[C], C[C] and D[H]. For a cooling problem, BK, B[C], A[H], B[H], A[C], D[C], C[H], D[H] and C[C].



ศูนย์วิทยทรัพยากร
จุฬาลงกรณ์มหาวิทยาลัย

Table 3.3 Match Pattern Operators of Class A and B

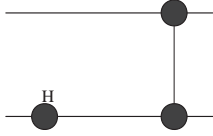
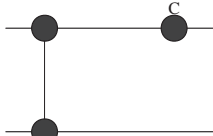
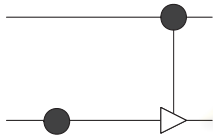
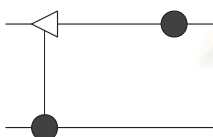
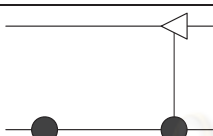
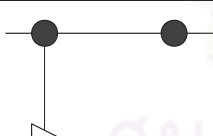
Match Operators	Conditions	Actions
 <p>Pattern AH</p>	$T_H^s * \geq T_C^t **$ $L_H \leq L_C$ $T_H^s \geq T_C^s + L_H W_C^{-1}$ $L_C - L_H \leq Q_{\min}^{heating}$	<p>Match H and C Status of H \Leftarrow Matched***</p> $T_C^s \Leftarrow T_C^s + L_H W_C^{-1}$ $L_C \Leftarrow L_C - L_H$
 <p>Pattern BK</p>	$T_H^s \geq T_C^t$ $L_C \leq L_H$ $T_C^s \leq T_H^s - L_C W_H^{-1}$ $L_H - L_C \leq Q_{\min}^{cooling}$	<p>Match H and C Status of C \Leftarrow Matched</p> $T_H^s \Leftarrow T_H^s - L_C W_H^{-1}$ $L_H \Leftarrow L_H - L_C$
 <p>Pattern A[H]</p>	$T_H^t \geq T_C^s$ $L_H \leq L_C$ $W_C \geq W_H$	<p>Match H and C Status of H \Leftarrow Matched</p> $T_C^s \Leftarrow T_C^s + L_H W_C^{-1}$ $L_C \Leftarrow L_C - L_H$
 <p>Pattern B[C]</p>	$T_H^s \geq T_C^t$ $L_C \leq L_H$ $W_C \leq W_H$	<p>Match H and C Status of C \Leftarrow Matched</p> $T_H^s \Leftarrow T_H^s - L_C W_H^{-1}$ $L_H \Leftarrow L_H - L_C$
 <p>Pattern A[C]</p>	$T_H^t \geq T_C^s$ $L_H \leq L_C$ $W_C < W_H$ $T_H^s \geq T_C^s + L_H W_C^{-1}$	<p>Match H and C Status of H \Leftarrow Matched</p> $T_C^s \Leftarrow T_C^s + L_H W_C^{-1}$ $L_C \Leftarrow L_C - L_H$
 <p>Pattern B[H]</p>	$T_H^s \geq T_C^t$ $L_C \leq L_H$ $W_H < W_C$ $T_C^s \leq T_H^s - L_C W_H^{-1}$	<p>Match H and C Status of C \Leftarrow Matched</p> $T_H^s \Leftarrow T_H^s - L_C W_H^{-1}$ $L_H \Leftarrow L_H - L_C$

* T^t =target temp, T^s =supply temp, W =heat capacity flowrate, L , Q =heat load.

** Cold stream temperatures are shifted up by ΔT_{\min} .

*** There are two statuses of process streams, 'active' and 'matched'. This will exclude this stream from a set of process streams to be selected next.

Table 3.4 Match Pattern Operators of Class C and D

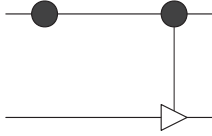
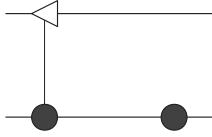
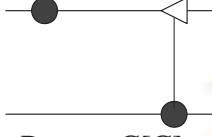
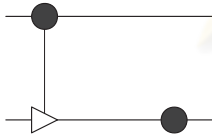
Match Operators	Conditions	Actions
 <p>Pattern C[H]</p>	$T_H^t \geq T_C^s$ $L_H > L_C$ $W_H \leq W_C$	<p>Match H and C Status of C \Leftarrow Matched</p> $T_H^t \Leftarrow T_H^t - L_C W_H^{-1}$ $L_H \Leftarrow L_H - L_C$
 <p>Pattern D[C]</p>	$T_H^s \geq T_C^t$ $L_H < L_C$ $W_H \geq W_C$	<p>Match H and C Status of H \Leftarrow Matched</p> $T_C^t \Leftarrow T_C^t + L_H W_C^{-1}$ $L_C \Leftarrow L_C - L_H$
 <p>Pattern C[C]</p>	$T_H^t \geq T_C^s$ $L_H > L_C$ $W_C < W_H$ $T_C^t \leq T_H^t + L_C W_H^{-1}$	<p>Match H and C Status of C \Leftarrow Matched</p> $T_H^t \Leftarrow T_H^t - L_C W_H^{-1}$ $L_H \Leftarrow L_H - L_C$
 <p>Pattern D[H]</p>	$T_H^s \geq T_C^t$ $L_H \leq L_C$ $W_H < W_C$ $T_H^t \geq T_C^t - L_H W_C^{-1}$	<p>Match H and C Status of H \Leftarrow Matched</p> $T_C^t \Leftarrow T_C^t + L_H W_C^{-1}$ $L_C \Leftarrow L_C - L_H$

* T^t =target temp, T^s =supply temp, W =heat capacity flow rate, L , Q =heat load.

** Cold stream temperatures are shifted up by ΔT_{\min} .

*** There are two statuses of process streams, 'active' and 'matched'. This will exclude this stream from a set of process streams to be selected next.

3.2.4.1 Regular Match Operators

The defined match patterns are used in the regular matches, the split matches, the one to many stream matches and the special case matches. These match patterns are used as operators or identifiers in HENs. Regular match operators are match patterns of two stream matches which require no splitting or any other qualification beside the descriptions of the patterns.

Regular match patterns and the testing conditions for Class A, B, C and D with [H] and [C] subclass characters are shown in Table 3.3 and 3.4.

3.2.4.2 Stream Split Match Operators

Devising stream split match operators is not an easy task, since there are few rules of how stream splitting can be done. Linnhoff and Hindmarsh (1983) list some observation rules for pinch matches when the splitting situation has been realized from observing the population and the heat capacity flow rate constraints. Stream splitting is very problem-specific so, split operations implemented in this work cannot be exclusive. There are numerous possibilities that one can explore with this type of problem. The only constraint that seems reasonable is that the number of splits be minimal.

Stream splitting is needed when matching would result in violating minimum utilities requirement or the thermodynamic (minimum temperature difference) constraint. There are two cases of stream splitting reported:

1. *Population constraint.* The first case arises when the number of hot streams is greater than the number of cold streams in a heating subproblem and vice versa in a cooling subproblem (Linnhoff and Hindmarsh, 1983).
2. *Heat capacity flow rate constraint.* Two different conditions indicate the need for stream splitting:
 - (a) In a hot side, the heat capacity flow rate of the hot stream is larger than that of the cold stream, and the target temperature of the cold stream is greater than the supply temperature of the hot stream, (otherwise, the hot stream can be matched to the cold stream at hot end position without having to be split).
 - (b) For a cold side, the heat capacity flow rate of the cold stream is larger than that of the hot stream, and the target temperature of the hot stream is lower than the supply temperature of the cold stream, (otherwise, the cold stream can be matched to the hot stream at cold end position without having to be split).

It should be noted here that the heat capacity flow rate difference bound, e.g. for a hot side, for all pinch matches,

$$\sum_i^{N_C} W_{C,i} - \sum_j^{N_H} W_{H,j} \leq \sum_k^{N_{matches}} W_{C,k} - W_{H,k} \quad (1)$$

suggested by Linnhoff and Hindmarsh is not necessarily a real constraint for splitting because one may find a match at the opposing position from the pinch where the heat capacity flow rate constraint is reversed. For example, in a hot side, for a match at the hot end position, the heat capacity flow rate of the hot stream being greater than that of the cold stream is favored. This match choice offers match opportunity when starting a match at pinch is not possible provided that the target temperature of the cold stream must be less than that of the hot stream.

There is still another constraint that will result in stream splitting besides the population and the heat capacity flow rate cases.

3. *Temperature constraint.* This is an essential split match. The situation arises when there is only one stream that can match to several other streams based on the temperature constraint. So, such a stream must be split otherwise, an unnecessary cooling or heating utility stream has to be matched to those constrained streams. For example, in a heating problem there are two hot streams whose target temperatures are lower than all of the supply temperatures of cold streams, except for one. That cold stream must be split and matched to the two hot streams.

The match pattern operators for these three cases are devised for the following situations:

1. Split one stream into two streams to match with two opposing streams.
2. Split one stream into two streams to match with one opposing stream.

Various splitting match patterns for these cases are shown in Table 3.5, 3.6 and 3.7. Each pattern in Table 3.5 and 3.6 is used for only a certain combination of the population or heat capacity flow rate cases with subproblem types-heating or cooling. For example, a pattern A2, shown in Table 3.5 (a), is for a heat capacity flow rate case in a heating subproblem. However, the pattern C2, shown in Table 3.5 (c), for heat capacity flow rate case in a hot side, can be used for a population case in a cold side. The pattern D2, shown in Table 3.6 (f), for a heat capacity flow rate case in a cold side can be used for a population case in a hot side.

Matching Conditions. The testing equations for the splitting patterns are shown in the tables.

A value of heat capacity flow rate of a stream i superscripted by a star (W_i^*) is an equivalent value adjusted so that the end temperatures of stream i and stream j at a match starting point are different by ΔT_{min} .

1. *Class A match.* For a match at a cold end position and $LH < LC$. See Table 3.5 (a), (b) and 3.6 (a).

$$W_C^* = W_C \left\{ 1 + \frac{T_H^t - (T_C^s + \Delta T_{min})}{T_H^s - (T_C^s + \Delta T_{min})} \right\} \quad (2)$$

$$W_H^* = W_H - W_C \frac{T_H^t - (T_C^s + \Delta T_{min})}{T_H^s - T_H^t} \quad (3)$$

2. *Class B match.* For a match at a hot end position and $LH > LC$. See Table 3.5 (d) and 3.6 (d), (e).

$$W_C^* = W_C - W_H \frac{T_H^s - (T_C^t + \Delta T_{min})}{T_C^t - T_C^s} \quad (4)$$

$$W_H^* = W_H \left\{ 1 + \frac{T_H^s - (T_C^t + \Delta T_{min})}{T_C^t - T_C^s} \right\} \quad (5)$$

3. *Class C match.* For a match at a cold end position and $LH > LC$. See Table 3.5 (c) and 3.6 (b), (c).

$$W_C^* = W_C \left\{ 1 + \frac{T_H^t - (T_C^s + \Delta T_{min})}{T_C^t - T_C^s} \right\} \quad (6)$$

$$W_H^* = W_H - W_C \frac{T_H^t - (T_C^s + \Delta T_{min})}{(T_C^t + \Delta T_{min}) - T_H^t} \quad (7)$$

4. *Class D match.* For a match at a hot end position and $LH < LC$. See Table 3.5 (e), (f) and 3.6 (f).

$$W_C^* = W_C - W_H \frac{T_H^s - (T_C^t + \Delta T_{min})}{(T_C^t + \Delta T_{min}) - T_H^t} \quad (8)$$

$$W_H^* = W_H \left\{ 1 + \frac{T_H^s - (T_C^s + \Delta T_{min})}{(T_C^t + \Delta T_{min}) - T_H^t} \right\} \quad (9)$$

The two splitting match patterns for a match of two streams are shown in Table 3.7. There are only two patterns possible for this case. Other patterns are irrelevant. Both patterns can be used either in a hot side or cold side.

If the end temperature difference between hot and cold streams where a match is started is small, W_i^* can be, simply and conservatively, the value of a heat capacity flow rate of stream i .

However, match pattern operators is more than, but it is unconcerned about this research. The person interesting can more study from the book "Resilient Heat Exchanger Network Design", Wongsri, M., 1990.

ศูนย์วิทยทรัพยากร
จุฬาลงกรณ์มหาวิทยาลัย

Table 3.5 Splitting Match Pattern Operators

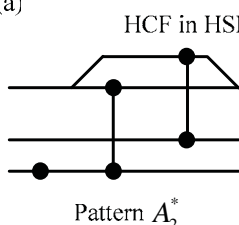
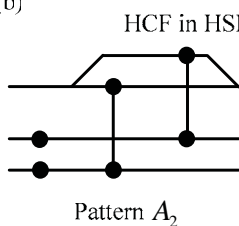
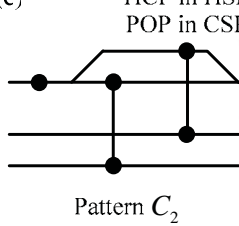
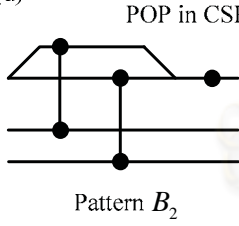
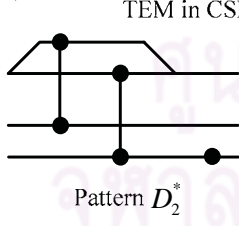
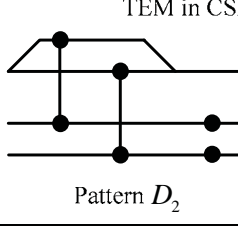
Match Operators	Conditions	Actions
(a)  HCF in HSP Pattern A_2^*	$T_H^t \geq T_{C1}^s, T_{C2}^s$ $L_H \leq L_{C1} + L_{C2}$ $L_H > L_{C1} \leq L_{C2}$ $W_H \leq W_{C1}^* + W_{C2}^*$	Split H with $W_{H1} = W_{C1}^* \leftrightarrow L_{H1} = L_{C1}$ Match split Hs to C1 and C2 Set stream conditions, e.g. status, temps, etc.
(b)  HCF in HSP Pattern A_2	$T_H^t \geq T_{C1}^s, T_{C2}^s$ $L_H \leq L_{C1} + L_{C2}$ $W_H \leq W_{C1}^* + W_{C2}^*$	Split H with a ratio of $[W_{C1}^* : W_{C2}^*]$ Match split Hs to C1 and C2 Set stream conditions, e.g. status, temps, etc.
(c)  HCF in HSP POP in CSP Pattern C_2	$T_H^t \geq T_{C1}^s, T_{C2}^s$ $L_H > L_{C1} + L_{C2}$ $W_H \leq W_{C1}^* + W_{C2}^*$	Split H with a ratio of $[W_{C1}^* : W_{C2}^*]$ Match split Hs to C1 and C2 Set stream conditions, e.g. status, temps, etc.
(d)  POP in CSP Pattern B_2	$T_H^s \geq T_{C1}^t, T_{C2}^t$ $L_H \geq L_{C1} + L_{C2}$ $W_H \geq W_{C1}^* + W_{C2}^*$	Split H with a ratio of $[W_{H1}^* : W_{H2}^*]$ Match split Hs to C1 and C2 Set stream conditions, e.g. status, temps, etc.
(e)  TEM in CSP Pattern D_2^*	$T_H^s \geq T_{C1}^t, T_{C2}^t$ $L_H < L_{C1} + L_{C2}$ $L_H > L_{C1} \leq L_{C2}$ $W_H \geq W_{C1}^* + W_{C2}^*$	Split H with $W_{H1} = W_{C1}^* \leftrightarrow L_{H1} = L_{C1}$ Match split Hs to C1 and C2 Set stream conditions, e.g. status, temps, etc.
(f)  TEM in CSP Pattern D_2	$T_H^s \geq T_{C1}^t, T_{C2}^t$ $L_H < L_{C1} + L_{C2}$ $W_H \geq W_{C1}^* + W_{C2}^*$	Split H with a ratio of $[W_{H1}^* : W_{H2}^*]$ Match split Hs to C1 and C2 Set stream conditions, e.g. status, temps, etc.

Note: HCF = Heat capacity flowrate case, POP = Population case, TEM = Temperature constraint case
 , HSP = Heating subproblem, CSP = Cooling subproblem

Table 3.6 Splitting Match Pattern Operators



Match Operators	Conditions	Actions
(a) POP in HSP  Pattern A^2	$T_{H1}^t, T_{H2}^t \geq T_C^s$ $L_{H1} + L_{H2} \leq L_C$ $W_{H1}^* + W_{H2}^* \leq W_C$	Split C with a ratio of $[W_{C1}^* : W_{C2}^*]$ Match split Cs to H1 and H2 Set stream conditions, e.g. status, temps, etc.
(b) TEM in HSP  Pattern C^{2*}	$T_{H1}^t, T_{H2}^t \geq T_C^s$ $L_{H1} + L_{H2} > L_C$ $L_{H2} \geq L_{H1} < L_C$ $W_{H1}^* + W_{H2}^* \leq W_C$	Split C with $L_{C1} = L_{H1}$ Match split Cs to H1 and H2 Set stream conditions, e.g. status, temps, etc.
(c) TEM in HSP  Pattern C^2	$T_{H1}^t, T_{H2}^t \geq T_C^s$ $L_{H1} + L_{H2} > L_C$ $W_{H1}^* + W_{H2}^* \leq W_C$	Split C with a ratio of $[W_{C1}^* : W_{C2}^*]$ Match split Cs to H1 and H2 Set stream condition, e.g. status, temps, etc.
(d) HCF in CSP  Pattern B^{2*}	$T_{H1}^s, T_{H2}^s \geq T_C^t$ $L_{H1} + L_{H2} \geq L_C$ $L_{H2} \geq L_{H1} < L_C$ $W_{H1}^* + W_{H2}^* \geq W_C$	Split C with $L_{C1} = L_{H1}$ Match split Cs to H1 and H2 Set stream condition, e.g. status, temps, etc.
(e) HCF in CSP  Pattern B^2	$T_{H1}^s, T_{H2}^s \geq T_C^t$ $L_{H1} + L_{H2} \geq L_C$ $W_{H1}^* + W_{H2}^* \geq W_C$	Split C with a ratio of $[W_{H1}^* : W_{H2}^*]$ Match split Cs to H1 and H2 Set stream condition, e.g. status, temps, etc.
(f) HCF in CSP POP in HSP  Pattern D^2	$T_{H1}^s, T_{H2}^s \geq T_C^t$ $L_{H1} + L_{H2} < L_C$ $W_{H1}^* + W_{H2}^* \geq W_C$	Split C with a ratio of $[W_{H1}^* : W_{H2}^*]$ Match split Cs to H1 and H2 Set stream condition, e.g. status, temps, etc.

Table 3.7 Splitting Match Pattern Operators

Match Operators	Conditions	Actions
HCF  Pattern $D_{1/2}$	$T_{H1}^s \geq T_C^t$ $L_H \leq L_C$ $W_H^* < W_C$	Split C with a ratio of $[W_{C1}^* : W_{C2}^*]$ Match split Cs to H1 and H2 Set stream conditions, e.g. status, temps, etc.
HCF  Pattern $C^{1/2}$	$T_{H1}^t \geq T_C^s$ $L_H \geq L_C$ $W_H < W_C^*$	Split C with $L_{C1} = L_{H1}$ Match split Cs to H1 and H2 Set stream conditions, e.g. status, temps, etc.

3.2.5 Disturbance Propagation Design Method

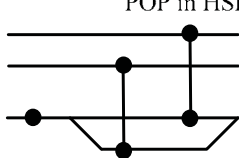
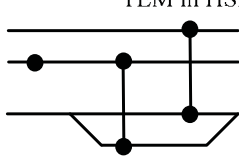
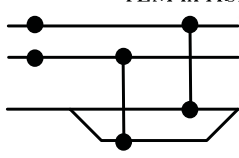
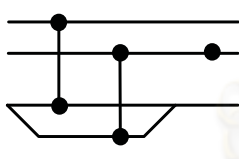
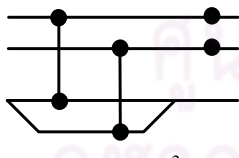
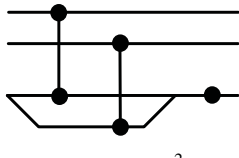
In order for a stream to be resilient with a specified disturbance load, the disturbance load must be transferred to heat sinks or heat sources within the network. With the use of the heuristic: To generate a heat exchanger network featuring the minimum number of heat transfer units, let each match eliminate at least one of the two streams.

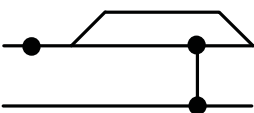
We can see that in a match of two heat load variable streams, the variation in heat load of the smaller stream S1 will cause a variation to the residual of the larger stream S2 by the same degree: in effect the disturbance load of S1 is shifted to the residual of S2. If the residual stream S2 is matched to S3 which has larger heat load, the same situation will happen. The combined disturbance load of S1 and S2 will cause the variation in the heat load to the residual S3. Hence, it is easy to see that the disturbance load in residual S3 is the combination of its own disturbance load and those obtained from S1 and S2. Or, if S2 is matched to a smaller heat load stream S4, the new disturbance load of residual S2 will be the sum of the disturbance loads of S1 and S4. From this observation, in order to be resilient, a smaller process stream with specified disturbance load must be matched to a larger stream that can tolerate its disturbance. In other words, the propagated disturbance will not overshoot the target temperature of the larger process stream.

propagated disturbance will not overshoot the target temperature of the larger process stream.

However, the amount of disturbance load that can be shifted from one stream to another depends upon the type of match patterns and the residual heat load. Hence, in design we must choose a pattern that yields the maximum resiliency. We can state that the resiliency requirement for a match pattern selection is that the entire disturbance load from a smaller heat load stream must be tolerated by a residual stream. Otherwise, the target temperature of the smaller stream will fluctuate by the unshifted disturbance. Of course, the propagated disturbance will be finally handled by utility exchangers. In short, the minimum heat load value of a larger stream must be less than a maximum heat load value of a smaller stream.

By choosing the minimum heat load condition for the design, the new input temperature of a residual stream to its design condition according to the propagated disturbance. The propagated disturbance will proportionally cause more temperature variation in the residual stream and the range of temperature variation of the residual stream will be larger than its original range.

Definition 3.5 Propagated Disturbance. The propagated disturbance of a stream is the disturbance caused by a variation in heat load of 'up-path' streams to which such a stream is matched. Only a residual stream will have a propagated disturbance. The new disturbance load of a residual stream will be the sum of its own disturbance (if any) and the propagated disturbance. See Figure 3.5 and 3.6.

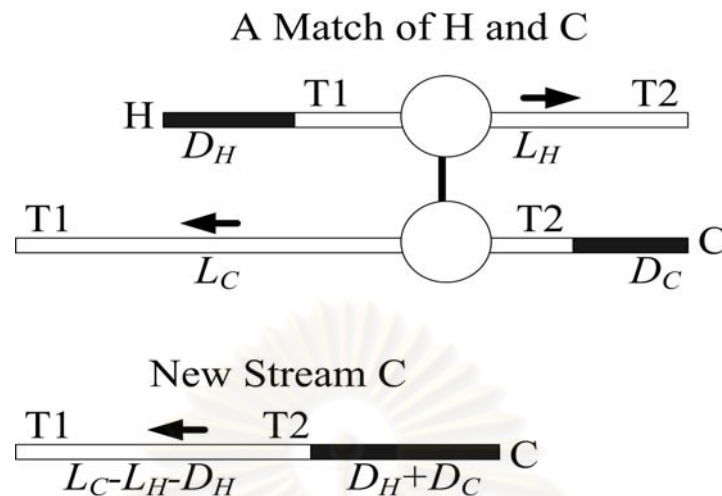

Figure 3.5: A Concept of Propagated Disturbance

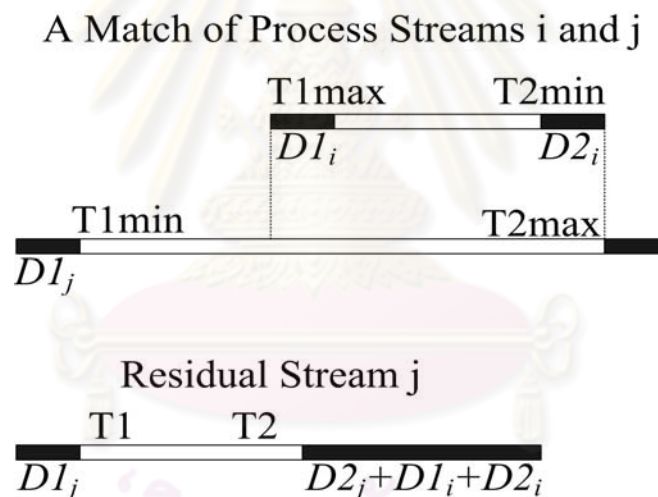

Figure 3.6: A General Concept of Propagated Disturbance

Hence, a stream with no original variation in heat load will be subjected to variation in heat load if it is matched to a stream with disturbance. Another design consideration is that the disturbance load travel path should be as short as possible, i.e. the least number of streams involved. Otherwise, the accumulated disturbance will be at high level. From the control point of view, it is difficult to achieve good control if the order of the process and the transportation lag are high. From the design viewpoint, one may not find heat sinks or sources that can handle the large amount of propagated disturbance (Wongsri, 1990).

3.2.6 Synthesis Procedures

A procedure of HEN synthesis by using math operators and a notion of a design state can be carried in step as follow:

1. Push the match operators to a stack in proper order. This is a beginning of a new state.
2. While there is an operator on a stack.
 - (a) Pop a match operator form a stack to operate on process streams.
 - (b) If a match is found, exclude matched streams from a set of process stream. Change the condition of residual streams. Include the residual streams in to a set of process streams. Go to a new design state (the first step).
3. If there are only hot or cold process streams left in the set of stream, a solution is found. If there are other solutions, they can be found by backtracking to the previous states to try the unused operators in those states.
4. If no matches is found in a current design state, back track to a previous stare to try an available operator on the stack of that state. (Go to Step 2 in the previous loop.) It is a recursive procedure here. If a math still could not be found, backtrack again to the more previous.

The above sequences represent a loop of one design state. A total generation procedure a loop composing of these sequences.

3.3 Plantwide Control

A typical chemical plant flowsheet has a mixture of multiple units connected both in series and parallel that consist of reaction sections, separation sections and heat exchanger network. Therefore, Plantwide Process Control involves the system and strategies required to control entire plant consisting of many interconnected unit operations.

3.3.1 Integrated Process

Figure 3.7 shows integrated process flowsheet. Three basic features of integrated chemical process lie at the root of our need to consider the entire plant's control system: the effect of material recycle, the effect of energy integration, and the need to account for chemical component inventories.

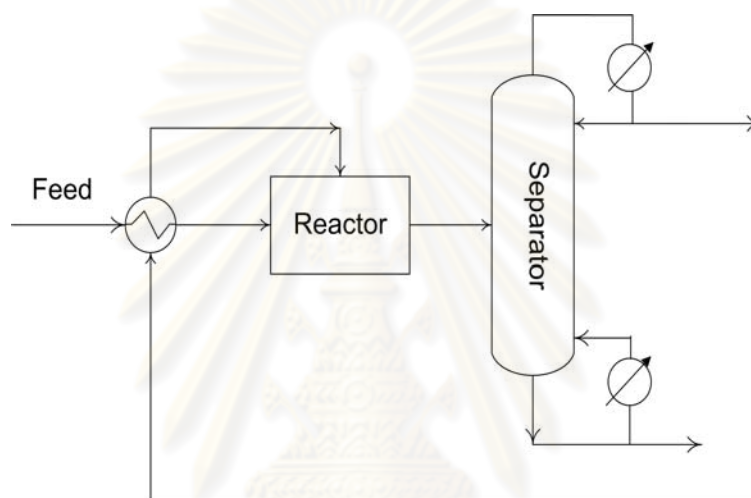

Figure 3.7: Integrated Process flowsheet

3.3.1.1 Material Recycles

Material is recycled for six basic and important reasons.

1. *Increase conversion.* For chemical processes involving reversible reactions, conversion of reactants to products is limited by thermodynamic equilibrium constraints. Therefore the reactor effluent by necessity contains both reactants and products. Separation and recycle of reactants are essential if the process is to be economically viable.

2. *Improve economics.* In most systems it is simply cheaper to build a reactor with incomplete conversion and recycle reactants than it is to reach the necessary conversion level in one reactor or several in series. A reactor followed by

a stripping column with recycle is cheaper than one large reactor or three reactors in series.

3. *Improve yields.* In reaction system such as $A \rightarrow B \rightarrow C$, where B is the desired product, the per-pass conversion of A must be kept low to avoid producing too much of the undesirable product C. Therefore the concentration of B is kept fairly low in the reactor and a large recycle of A is required.

4. *Provide thermal sink.* In adiabatic reactors and in reactors where cooling is difficult and exothermic heat effects are large, it is often necessary to feed excess material to the reactor (an excess of one reactant or a product) so that the reactor temperature increase will not be too large. High temperature can potentially create several unpleasant events: it can lead to thermal runaways, it can deactivate catalysts, it can cause undesirable side reactions, it can cause mechanical failure of equipment, etc. So the heat of reaction is absorbed by the sensible heat required to rise the temperature of the excess material in the stream flowing through the reactor.

5. *Prevent side reactions.* A large excess of one of the reactants is often used so that the concentration of the other reactant is kept low. If this limiting reactant is not kept in low concentration, it could react to produce undesirable products. Therefore the reactant that is in excess must be separated from the product components in the reactor effluent stream and recycled back to the reactor.

6. *Control properties.* In many polymerization reactors, conversion of monomer is limited to achieve the desired polymer properties. These include average molecular weight, molecular weight distribution, degree of branching, particle size, etc. Another reason for limiting conversion to polymer is to control the increase in viscosity that is typical of polymer solutions. This facilitates reactor agitation and heat removal and allows the material to be further processed.

3.3.1.2 Energy Integration

The fundamental reason for the use of energy integration is to improve the thermodynamics efficiency of the process. This translates into a reduction in utility cost.

3.3.1.3 Chemical Component Inventories

In chemical processes can characterize a plant's chemical species into three types: reactants, products, and inert. The real problem usually arises when we consider reactants (because of recycle) and account for their inventories within the entire process. Every molecule of reactants fed into the plant must either be consumed or leave as impurity or purge. Because of their value so we prevent reactants from leaving. This means we must ensure that every mole of reactant fed to the process is consumed by the reactions.

This is an important, from the viewpoint of individual unit; chemical component balancing is not a problem because exit streams from the unit automatically adjust their flows and composition. However, when we connect units together with recycle streams, the entire system behaves almost like a pure integrator in terms of reactants. If additional reactant is fed into the system without changing reactor conditions to consume the reactants, this component will build up gradually within the plant because it has no place to leave the system.

3.3.2 Effects of Recycle

Most real processes contain recycle streams. In this case the plantwide control problem becomes much more complex. Two basic effect of recycle is: Recycle has an impact on the dynamics of the process. The overall time constant can be much different than the sum of the time constants of the time constants of the individual units. Recycle leads to the "snowball" effect. A small change in throughput or feed composition can lead to a large change in steady-state recycle

stream flowrates.

Snowball Effect: Snowball effect is high sensitivity of the recycle flow rates to small disturbances. When feed conditions are not very different, recycle flow rates increase drastically, usually over a considerable period of time. Often the equipment cannot handle such a large load. It is a steady-state phenomenon but it does have dynamic implications for disturbance propagation and for inventory control.

The large swings in recycle flowrates are undesirable in plant because they can overload the capacity of separation section or move the separation section into a flow region below its minimum turndown. Therefore it is important to select a plantwide control structure that avoids this effect.

3.3.3 Plantwide Control Design Procedures

Step1: Establish control objectives

Assess the steady-state design and dynamic control objects for the process. This is probably the most important aspect of the problem because different control objectives lead to different control structures. The "best" control structure for a plant depends upon the design and control criteria established.

These objectives include reactor and separation yields, product quality specification, product grades and demand determination, environmental restrictions, and the range of safe operating conditions.

Step 2: Determine control degrees of freedom

This is the number of degrees of freedom for control, i.e., the number of variables that can be controlled to set point. The placement of these control valves can sometimes be made to improve dynamic performance, but often there is no choice in their location.

Most of these valves will be used to achieve basic regulatory control of the process: set production rate, maintain gas and liquid inventories, control product qualities, and avoid safety and environmental constraints. Any valves that remain after these vital tasks have been accomplished can be utilized to enhance steady-state economic objectives or dynamic controllability (e.g. minimizes energy consumption, maximize yield, or reject disturbances).

Step 3: Establish energy management system

Make sure that energy disturbances do not propagate throughout the process by transferring the variability to the plant utility system.

We use the term energy management to describe two functions.

1. We must provide a control system that removes exothermic heats of reaction from the process. If heat is not removed to utilities directly at the reactor, then it can be used elsewhere in the process by other unit operations. This heat, however, must ultimately be dissipated to utilities.
2. If heat integration does occur between process streams, then the second function of energy management is to provide a control system that prevents the propagation of thermal disturbances and ensure the exothermic reactor heat is dissipated and not recycled. Process-to-process heat exchangers and heat-integrated unit operations must be analyzed to determine that there are sufficient degrees of freedom for control.

Heat removal in exothermic reactors is crucial because of the potential for thermal runaways. In endothermic reactions, failure to add enough heat simply results in the reaction slowing up. If the exothermic reactor is running adiabatically, the control system must prevent excessive temperature rise through the reactor.

Heat integration of a distillation column with other columns or with reactors is widely used in chemical plants to reduce energy consumption. While these

designs look great in terms of steady-state economics, they can lead to complex dynamic behavior and poor performance due to recycling of disturbances. If not already included in the design, trim heater/cooler or heat exchanger bypass line must be added to prevent this. Energy disturbances should be transferred to the plant utility system whenever possible to remove this source of variability from the process units.

Step 4: Set production rate

Establish the variable that dominates the productivity of the reactor and determine the most appropriate manipulator to control production rate. To obtain higher production rate, we must increase overall reaction rates. This can be accomplished by raising temperature, increasing reactant concentrations, increasing reactor holdup, or increasing reactor pressure. The variable we select must be dominant for the reactor

We often want to select a variable that has the least effect on the separation section but also has a rapid and direct effect on reaction rate in the reactor without hitting an operational constraint.

Step 5: Control product quality and handle safety, operational, and environmental constraints

We should select manipulated variables such that the dynamic relationships between the controlled and manipulated variables feature small time constants and dead times and large steady-state gains.

It should be noted that, since product quality considerations have become more important, so it should be established the product-quality loops first, before the material balance control structure.

Step 6: Fix a flow in every recycle loop and control inventories (pressure and level)

In most process a flow controller should be present in all liquid recycle loops. This is a simple and effective way to prevent potentially large changes in recycle flows that can occur if all flows in the recycle loop are controlled by level. We have to determine what valve should be used to control each inventory variable. Inventories include all liquid levels (except for surge volume in certain liquid recycle streams) and gas pressures. An inventory variable should be controlled with the manipulate variable that has the largest effect on it within that unit (Richardson rule).

Gas recycle loops are normally set at maximum circulation rate, as limited by compressor capacity, to achieve maximum yields (Douglas doctrine)

Proportional-only control should be used in non-reactive level loops for cascade units in series. Even in reactor level control, proportional control should be considered to help filter flowrate disturbances to the downstream separation system.

Step 7: Check component balances

Component balances are particularly important in process with recycle streams because of their integrating effect. We must identify the specific mechanism or control loop to guarantee that there will be no uncontrollable buildup of any chemical component within the process (Downs drill).

In process, we don't want reactant components to leave in the product streams because of the yield loss and the desired product purity specification. Hence we are limited to the use of two methods: consuming the reactants by reaction or adjusting their fresh feed flow. The purge rate is adjusted to control the inert composition in the recycle stream so that an economic balance is maintained between capital and operating costs.

Step 8: Control individual unit operations

Establish the control loops necessary to operate each of the individual unit operations. A tubular reactor usually requires control of inlet temperature. High-temperature endothermic reactions typically have a control system to adjust the fuel flowrate to a furnace supplying energy to the reactor.

Step 9: Optimize economics or improve dynamic controllability

After satisfying all of the basic regulatory requirements, we usually have additional degrees of freedom involving control valves that have not been used and setpoints in some controllers that can be adjusted. These can be used either to optimize steady-state economic process performance (e.g. minimize energy, maximize selectivity) or improve dynamic response.

3.4 Control of Process-to-Process Exchangers

Process-to-process (P/P) exchangers are used for heat recover within a process. We can control the two exit temperatures provided we can independently manipulate the two inlet flowrates. However, these flowrates are normally unavailable for us to manipulate and we therefore give up two degrees of freedom fairly easily. It is possible to oversize the P/P exchanger and provides a controlled bypass around it as in Fig 3.8.a. It is possible to combine the P/P exchanger with a utility exchanger as in Fig 3.8.b.

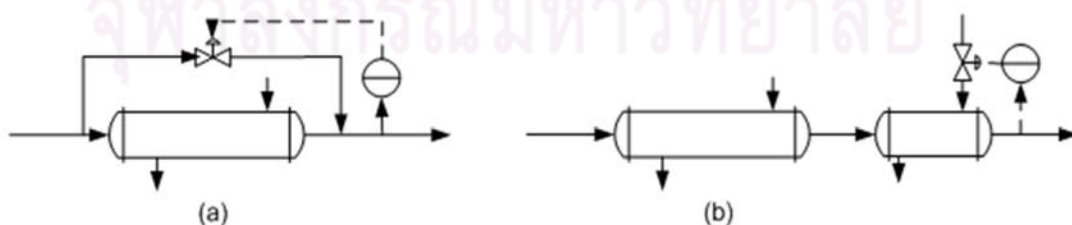

Figure 3.8: Control of P/P heat exchangers: (a) use of bypass; (b) use of auxiliary utility exchanger

3.4.1 Use of Bypass Control

When the bypass method is used for unit operation control, we have several choices about the bypass location and the control point. Figure 3.8(b) shows the most common alternatives. For choosing the best option, it depends on how we define the best. Design consideration might suggest, we measure and bypass on the cold side since it is typically less expensive to install a measurement device and a control valve for cold service than it is for high-temperature service. Cost consideration would also suggest a small bypass flow to minimize the exchanger and control valve sizes.

From a control standpoint, we should measure the most important stream, regardless of temperature, and bypass on the same side as well we control (see Figure 3.9 a and c). This minimizes the effects of exchanger dynamics in the loop. We should also want to bypass a large fraction of the controlled stream since it improves the control range. This requires a large heat exchanger. There are several general heuristic guidelines for heat exchanger bypass streams. We typically want to bypass the flow of the stream whose temperature we want to control. The bypass should be about 5 to 10 percent of the flow to be able to handle disturbances. Finally, we must carefully consider the fluid mechanics of the bypass design for the pressure drops through the control valves and heat exchanger.

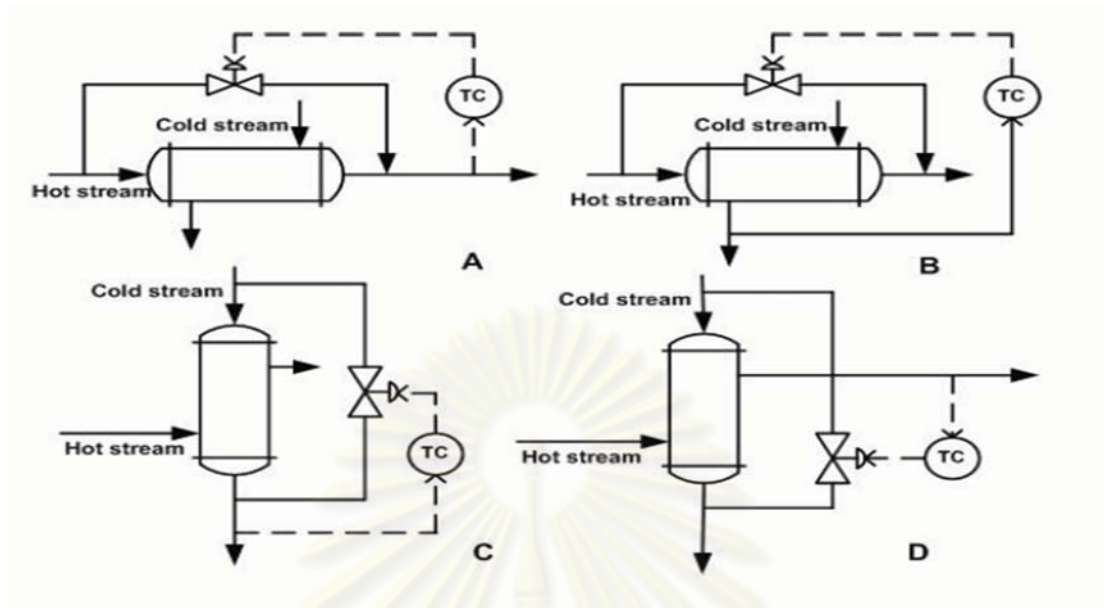

Figure 3.9: Bypass control of process-to process heat exchangers. (a) Controlling and bypassing hot stream; (b) controlling cold stream and bypassing hot stream; (c) controlling and bypassing cold stream; (d) controlling hot stream and bypassing hot stream.

3.4.2 Use of Auxiliary Exchangers

When the P/P exchanger is combined with a utility exchanger, we also have a few design decisions to make. We must first establish the relative sizes between the recovery and the utility exchanger large and the utility exchanger small. This gives us the most heat recovery, and it is also the least expensive alternative from an investment standpoint. However, a narrow control range and the inability to reject disturbance make this choice this choice the least desirable from a control standpoint.

Next, we must decide how to combine the utility exchanger with the P/P exchanger. This could be done either in a series or parallel arrangement. Physical implementation issues may dictate this choice but it could affect controllability. Finally, we have to design hoe to control the utility exchanger for best overall control performance. Consider a distillation column that uses a large amount of

high-pressure stream in its thermo siphon reboiler. To reduce operating costs we would like to heat-integrate this column with the reactor. A practical way of suggested. We can then use some or all of this stream to help reboil the column by condensing the stream in the tubes of a stab-in reboiler. However, the total heat from the reactor may not be enough to reboil the column, so the remaining heat must come from the thermo siphon reboiler that now serves as an auxiliary reboiler. The column tray temperature controller would manipulate the stream to the thermo siphon reboiler.

3.5 Cascade Control

One of the most useful concepts in advanced control is cascade control. A cascade control structure has two feedback controllers with the output of the primary (or master) controller changing the setpoint of the secondary (or slave) controller. The output of the secondary goes to the slave.

There are two purposes for cascade control: (1) to eliminate the effects of some disturbances, and (2) to improve the dynamic performance of the control loop.

To illustrate the disturbance rejection effect, consider the distillation column reboiler. Suppose the steam supply pressure increases. The pressure drop over the control valve will be larger, so the steam flow rate will increase. With the single-loop temperature controller, no correction will be made until the higher steam flow rate increases the vapor boilup and the higher vapor rate begins to rise the temperature on tray. Thus the whole system is disturbed by a supply-steam pressure change.

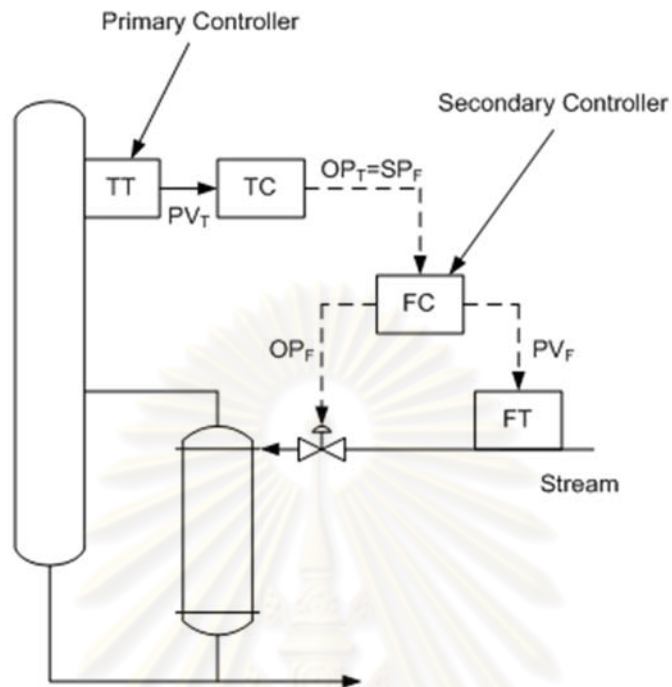

Figure 3.10: Cascade control in distillation-column-reboiler

With the cascade control system, the steam flow controller will immediately see the increase in steam flow and will pinch back on the steam valve to return the steam flow rate to its setpoint. Thus the reboiler and the column are only slightly affected by the steam supply-pressure disturbance.

Figure 3.10 shows another common system where cascade control is used. The reactor temperature controller is the primary controller; the jacket temperature controller is the secondary controller. The reactor temperature control is isolated by the cascade system from disturbance in cooling-water inlet temperature and supply pressure.

CHAPTER IV

PROCESS AND DESIGN

4.1 Process Description

The simplified flowsheet of the TEP used in this work is shown in Figure 4.1. In a typical TEP, the natural gas is cooled to extremely low temperatures through a HEN after which the cold liquid and vapor are separated in a low-temperature separator (LTS). The liquid stream of the LTS is flashed across a Joule-Thomson (JT) valve for pressure reduction and additional cooling. The vapor stream of the LTS is fed to the expander side of the TEP where temperature is further reduced and the work produced is utilized for recompression. The liquid generated by the expander is separated in the vapor-liquid separator (VLS). This liquid as well as the JT valve outlet are both fed to the top of the Demethanizer Tower (DT) (a reboiled absorber), the bottom product of which is the ethane-rich stream. The vapors from the DT and VLS are combined and fed back to the HEN to help cooling of the incoming natural-gas feed stream. The residue-gas (sales gas) stream (rich in methane) leaving the HEN is partially compressed using the energy released in the expander.

Efficient heat integration in the HEN, which is used to pre-cool the feed to the LTS, is of major importance in the design of TEPs. The HEN should maximize the cooling of the feed by matching it with the overhead (methane-rich) stream and with the reboiler of the DT. The HEN also helps to maintain high ethane recovery and high methane rejection in the bottoms of the DT. With respect to TEP, the heat integration efficiency may be defined as the ability of the HEN to achieve chilling of the natural-gas feed before entering the expander part of the plant with minimum external cooling requirement. The HEN structure shown in Figure 4.2 was among the alternative structures.

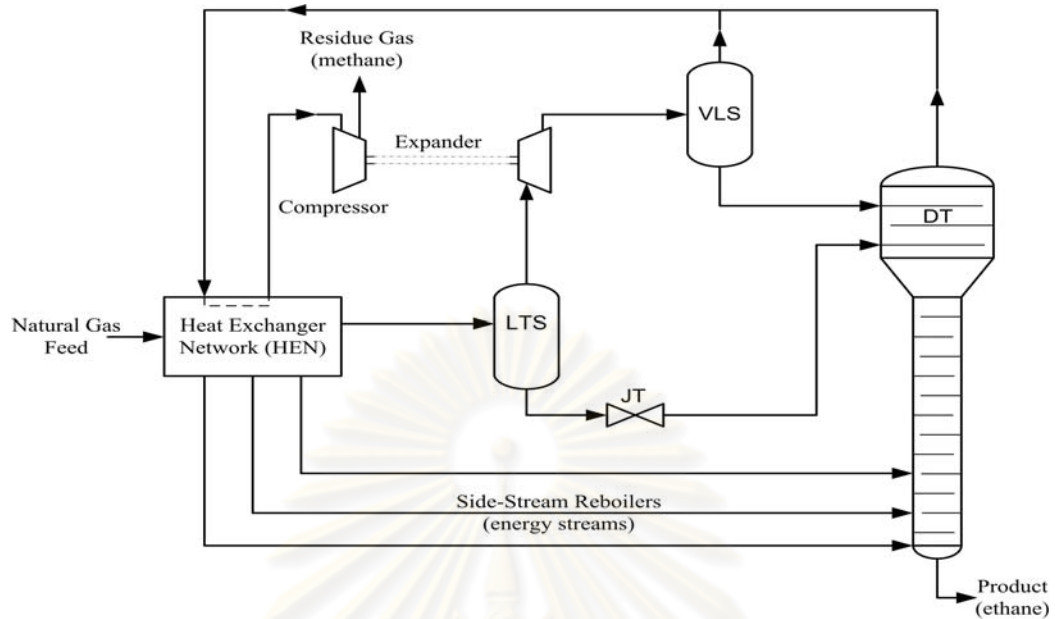

Figure 4.1: Simplified flowsheet of the turbo-expander plant (Konukman and Akman, 2005)

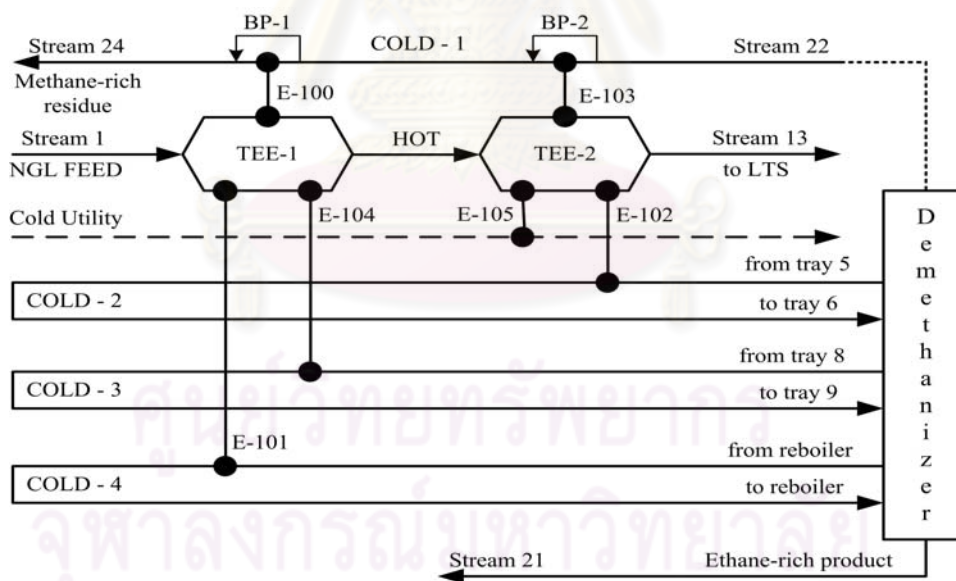

Figure 4.2: The flowsheet of the HEN base case in the form of grid diagram.

4.2 Design of Heat Exchanger Networks

At this point, the heat exchanger network design method provided by Wongsri (1990) is used to design the heat exchanger networks for natural gas

expander plant. The design procedures and definitions from previous chapters will be methods to design and compare with the preliminary stage of a process design without energy integration. The Problem Table Method is applied to find pinch temperature and reach maximum energy recovery (MER). The cost estimated will be consequence to compare and choose the best network that more optimal for the natural gas expander plant. The information for design is shown in the following Table 4.1

Table 4.1: The information of the natural gas expander plant.

Stream Name	T _{in} (°C)	T _{out} (°C)	W (MJ/hr °C)	duty (MJ/hr)
H1:NGL Feed	35	-51.56	369.25	31963
C1:Methane-rich residue	-94.10	18.55	170.57	19215
C2:From tray 5 to tray 6	-83.87	-76.52	204.23	1500
C3:From tray 8 to tray 9	-72.34	-61.77	141.85	1500
C3:Reboiler	-37.18	-7.67	160.49	4735

In Table 4.1, there is no pinch temperature when we use pinch method, which use the minimum temperature difference, equal to 10 °C. However, we can find the minimum utility requirements which equal 4988 MJ/hr of cold utilities.

Table 4.2: Process stream data for all alternatives

Stream	W	Supply Temp			Target Temp		
		Nom	Max	Min	Nom	Max	Min
H1	369.25	35.00	40.00	30.00	-51.56	-	-
C1	170.57	-94.10	-89.10	-99.10	18.55	-	-
C2	204.23	-83.87	-81.87	-85.87	-76.52	-	-
C3	141.85	-72.34	-70.34	-74.34	-61.77	-	-
C4	160.49	-37.18	-35.18	-39.18	-7.67	-	-

4.2.1 HEN Base Case

The HEN of base case was obtained from a task of Akman and Konukman, 2005. The flowsheet of the HEN base case in the form of grid diagram is shown in Figure 4.2.

4.2.2 HEN Alternative 1

In previous chapter, the Alternative 1 can be written a simply heat exchanger network as following: See Figure 4.3.

There are five streams in the network. We can find the minimum utility requirements which equal 4988 MJ/hr of cold utilities.

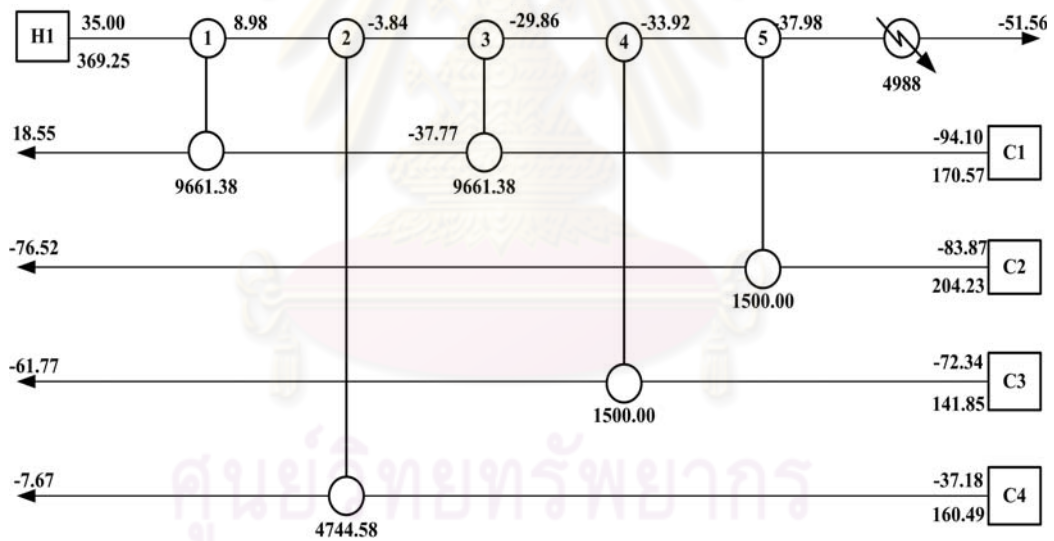

Figure 4.3: The heat exchanger network of Alternative 1, HEN-1

By using synthesis procedure that provided by Wongsri (1990), we can receive the resilient network from the synthesis tables as following Table 4.3.

Table 4.3: Synthesis Table for Alternative 1

Stream	Load	W	T1	T2	D1	D2	Action
a) State 1							
H1	30204.18	370.32	30.00	-51.56	3703.25	0.00	Selected B[C]
C1	18465.11	171.53	18.55	-89.10	0.00	1715.30	Selected
C2	1091.54	204.23	-76.52	-81.87	0.00	816.93	
C3	1216.30	141.85	-61.77	-70.34	0.00	567.40	
C4	4422.95	160.82	-7.67	-35.18	0.00	643.27	
b) State 2							
H1	20971.62	370.32	5.07	-51.56	3703.25	0.00	Selected B[C]
C1	9232.56	171.53	-35.27	-89.10	0.00	1715.30	
C2	1091.54	204.23	-76.52	-81.87	0.00	816.93	
C3	1216.30	141.85	-61.77	-70.34	0.00	567.40	
C4	4422.95	160.82	-7.67	-35.18	0.00	643.27	Selected
c) State 3							
H1	15905.41	370.32	-8.61	-51.56	4346.51	0.00	Selected B[C]
C1	9232.56	171.53	-35.27	-89.10	0.00	1715.30	Selected
C2	1091.54	204.23	-76.52	-81.87	0.00	816.93	
C3	1216.30	141.85	-61.77	-70.34	0.00	567.40	
d) State 4							
H1	4957.56	370.32	-38.17	-51.56	6061.81	0.00	Selected BK
C2	1091.54	204.23	-76.52	-81.87	0.00	816.93	
C3	1216.30	141.85	-61.77	-70.34	0.00	567.40	Selected
e) State 5							
H1	3173.86	370.32	-42.99	-51.56	6629.21	0.00	Selected BK
C2	1091.54	204.23	-76.52	-81.87	0.00	816.93	Selected
f) State 6							
H1	1265.39	370.32	-48.14	-51.56	7446.14	0.00	To Cooler

4.2.3 HEN Alternative 2

In previous chapter, the Alternative 2 can be written a simply heat exchanger network as following: See Figure 4.4.

There are five streams in the network. We can find the minimum utility requirements which equal 4988 MJ/hr of cold utilities.

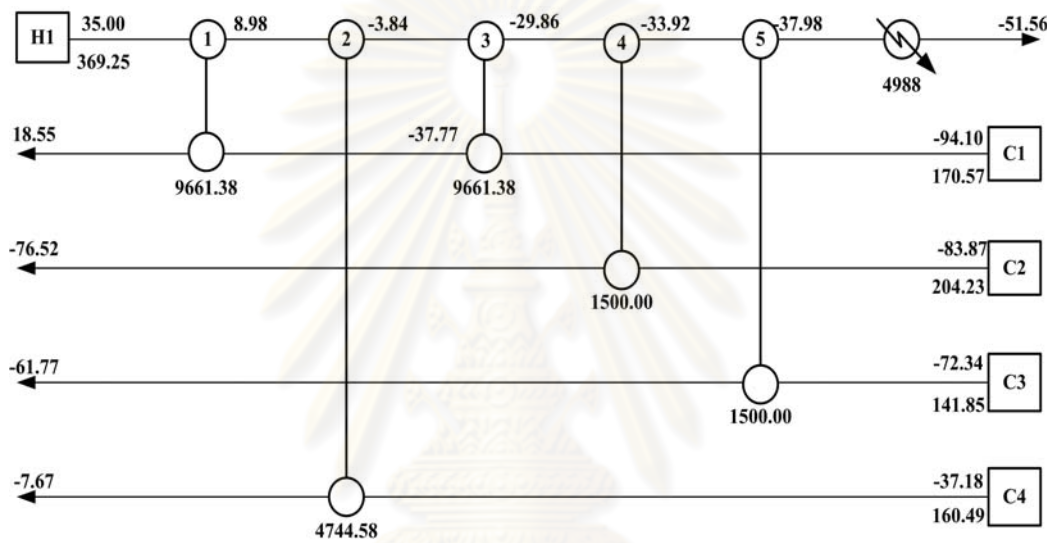

Figure 4.4: The heat exchanger network of Alternative 2, HEN-2

By using synthesis procedure that provided by Wongsri (1990), we can receive the resilient network from the synthesis tables as following Table 4.4.

Table 4.4: Synthesis Table for Alternative 2

Stream	Load	W	T1	T2	D1	D2	Action
a) State 1							
H1	30204.18	370.32	30.00	-51.56	3703.25	0.00	Selected B[C]
C1	18465.11	171.53	18.55	-89.10	0.00	1715.30	Selected
C2	1091.54	204.23	-76.52	-81.87	0.00	816.93	
C3	1216.30	141.85	-61.77	-70.34	0.00	567.40	
C4	4422.95	160.82	-7.67	-35.18	0.00	643.27	
b) State 2							

H1	20971.62	370.32	5.07	-51.56	3703.25	0.00	Selected B[C]
C1	9232.56	171.53	-35.27	-89.10	0.00	1715.30	
C2	1091.54	204.23	-76.52	-81.87	0.00	816.93	
C3	1216.30	141.85	-61.77	-70.34	0.00	567.40	
C4	4422.95	160.82	-7.67	-35.18	0.00	643.27	Selected
c) State 3							
H1	15905.41	370.32	-8.61	-51.56	4346.51	0.00	Selected B[C]
C1	9232.56	171.53	-35.27	-89.10	0.00	1715.30	Selected
C2	1091.54	204.23	-76.52	-81.87	0.00	816.93	
C3	1216.30	141.85	-61.77	-70.34	0.00	567.40	
d) State 4							
H1	4957.56	370.32	-38.17	-51.56	6061.81	0.00	Selected BK
C2	1091.54	204.23	-76.52	-81.87	0.00	816.93	Selected
C3	1216.30	141.85	-61.77	-70.34	0.00	567.40	
e) State 5							
H1	3049.09	370.32	-43.33	-51.56	6878.74	0.00	Selected BK
C3	1216.30	141.85	-61.77	-70.34	0.00	567.40	Selected
f) State 6							
H1	1265.39	370.32	-48.14	-51.56	7446.14	0.00	To Cooler

4.2.4 HEN Alternative 3

In previous chapter, the Alternative 3 can be written a simply heat exchanger network as following: See Figure 4.5.

There are five streams in the network. We can find the minimum utility requirements which equal 4988 MJ/hr of cold utilities.

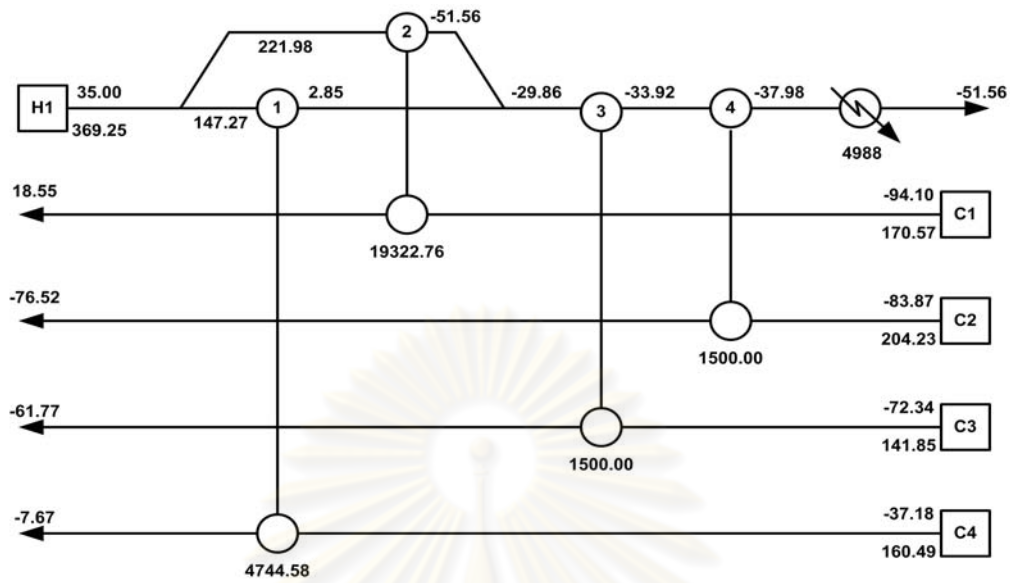

Figure 4.5: The heat exchanger network of Alternative 3, HEN-3

By using synthesis procedure that provided by Wongsri (1990), we can receive the resilient network from the synthesis tables as following Table 4.5.

Table 4.5: Synthesis Table for Alternative 3

Stream	Load	W	T1	T2	D1	D2	Action
a) State 1							
H1	30204.18	370.32	30.00	-51.56	3703.25	0.00	Split
H11	18206.63	223.23	30.00	-51.56	2232.26	0.00	Selected POP in CSP
H12	11997.55	147.10	30.00	-51.56	1470.98	0.00	Selected POP in CSP
C1	18465.11	171.53	18.55	-89.10	0.00	1715.30	Selected
C2	1091.54	204.23	-76.52	-81.87	0.00	816.93	
C3	1216.30	141.85	-61.77	-70.34	0.00	567.40	
C4	4422.95	160.82	-7.67	-35.18	0.00	643.27	Selected
b) State 2							
H1	4957.56	370.32	-38.17	-51.56	6061.81	0.00	Selected BK
H11	-1973.78	223.23	-60.40	-51.56	3947.56	0.00	Combined
H12	6931.34	147.10	-4.44	-51.56	2114.25	0.00	Combined
C1							Matched to H11
C2	1091.54	204.23	-76.52	-81.87	0.00	816.93	

C3	1216.30	141.85	-61.77	-70.34	0.00	567.40	Selected
C4							Matched to H12
c) State 3							
H1	3173.86	370.32	-42.99	-51.56	6629.21	0.00	Selected BK
C2	1091.54	204.23	-76.52	-81.87	0.00	816.93	Selected
d) State 4							
H1	1265.39	370.32	-48.14	-51.56	7446.14	0.00	To Cooler

4.2.5 HEN Alternative 4

In previous chapter, the Alternative 4 can be written a simply heat exchanger network as following: See Figure 4.6.

There are five streams in the network. We can find the minimum utility requirements which equal 4988 MJ/hr of cold utilities.

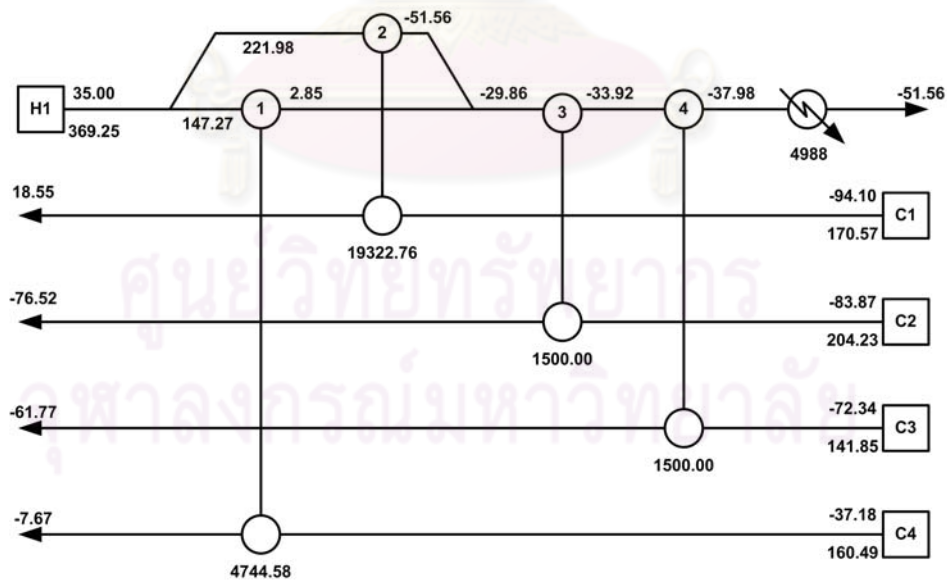

Figure 4.6: The heat exchanger network of Alternative 4, HEN-4

By using synthesis procedure that provided by Wongsri (1990), we can receive the resilient network from the synthesis tables as following Table 4.6.

Table 4.6: Synthesis Table for Alternative 4

Stream	Load	W	T1	T2	D1	D2	Action
a) State 1							
H1	30204.18	370.32	30.00	-51.56	3703.25	0.00	Split
H11	18206.63	223.23	30.00	-51.56	2232.26	0.00	Selected POP in CSP
H12	11997.55	147.10	30.00	-51.56	1470.98	0.00	Selected POP in CSP
C1	18465.11	171.53	18.55	-89.10	0.00	1715.30	Selected
C2	1091.54	204.23	-76.52	-81.87	0.00	816.93	
C3	1216.30	141.85	-61.77	-70.34	0.00	567.40	
C4	4422.95	160.82	-7.67	-35.18	0.00	643.27	Selected
b) State 2							
H1	4957.56	370.32	-38.17	-51.56	6061.81	0.00	Selected BK
H11	-1973.78	223.23	-60.40	-51.56	3947.56	0.00	Combined
H12	6931.34	147.10	-4.44	-51.56	2114.25	0.00	Combined
C1							Matched to H11
C2	1091.54	204.23	-76.52	-81.87	0.00	816.93	Selected
C3	1216.30	141.85	-61.77	-70.34	0.00	567.40	
C4							Matched to H12
c) State 3							
H1	3049.09	370.32	-43.33	-51.56	6878.74	0.00	Selected BK
C3	1216.30	141.85	-61.77	-70.34	0.00	567.40	Selected
d) State 4							
H1	1265.39	370.32	-48.14	-51.56	7446.14	0.00	To Cooler

4.2.6 HEN Alternative 5

In previous chapter, the Alternative 5 can be written a simply heat exchanger network as following: See Figure 4.7.

There are five streams in the network. We can find the minimum utility requirements which equal 4988 MJ/hr of cold utilities.

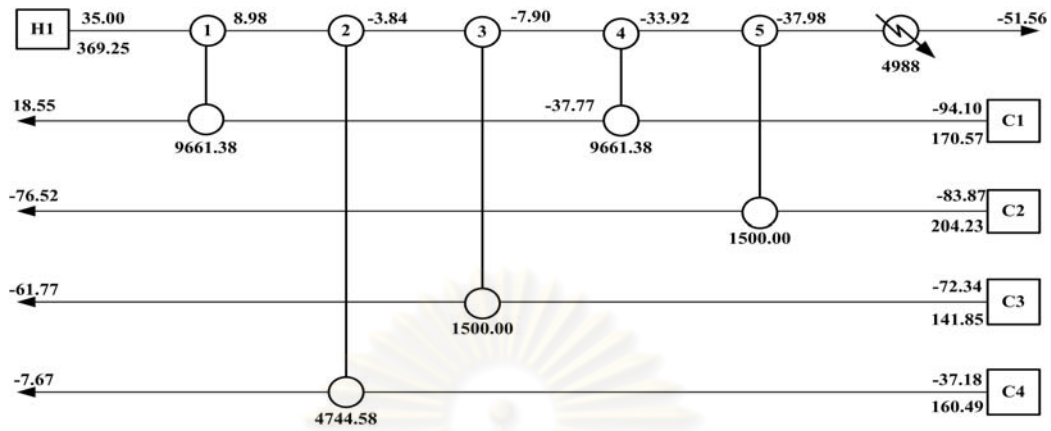

Figure 4.7: The heat exchanger network of Alternative 5, HEN-5

By using synthesis procedure that provided by Wongsri (1990), we can receive the resilient network from the synthesis tables as following Table 4.7.

Table 4.7: Synthesis Table for Alternative 5

Stream	Load	W	T1	T2	D1	D2	Action
a) State 1							
H1	30204.18	370.32	30.00	-51.56	3703.25	0.00	Selected B[C]
C1	18465.11	171.53	18.55	-89.10	0.00	1715.30	Selected
C2	1091.54	204.23	-76.52	-81.87	0.00	816.93	
C3	1216.30	141.85	-61.77	-70.34	0.00	567.40	
C4	4422.95	160.82	-7.67	-35.18	0.00	643.27	
b) State 2							
H1	20971.62	370.32	5.07	-51.56	3703.25	0.00	Selected B[C]
C1	9232.56	171.53	-35.27	-89.10	0.00	1715.30	
C2	1091.54	204.23	-76.52	-81.87	0.00	816.93	
C3	1216.30	141.85	-61.77	-70.34	0.00	567.40	
C4	4422.95	160.82	-7.67	-35.18	0.00	643.27	Selected
c) State 3							
H1	15905.41	370.32	-8.61	-51.56	4346.51	0.00	Selected B[C]
C1	9232.56	171.53	-35.27	-89.10	0.00	1715.30	

C2	1091.54	204.23	-76.52	-81.87	0.00	816.93	
C3	1216.30	141.85	-61.77	-70.34	0.00	567.40	Selected
d) State 4							
H1	14121.71	370.32	-13.43	-51.56	4913.92	0.00	Selected B[C]
C1	9232.56	171.53	-35.27	-89.10	0.00	1715.30	Selected
C2	1091.54	204.23	-76.52	-81.87	0.00	816.93	
e) State 5							
H1	3173.86	370.32	-42.99	-51.56	6629.21	0.00	Selected BK
C2	1091.54	204.23	-76.52	-81.87	0.00	816.93	Selected
f) State 6							
H1	1265.39	370.32	-48.14	-51.56	7446.14	0.00	To Cooler

4.2.7 HEN Alternative 6

In previous chapter, the Alternative 6 can be written a simply heat exchanger network as following: See Figure 4.8.

There are five streams in the network. We can find the minimum utility requirements which equal 4988 MJ/hr of cold utilities.

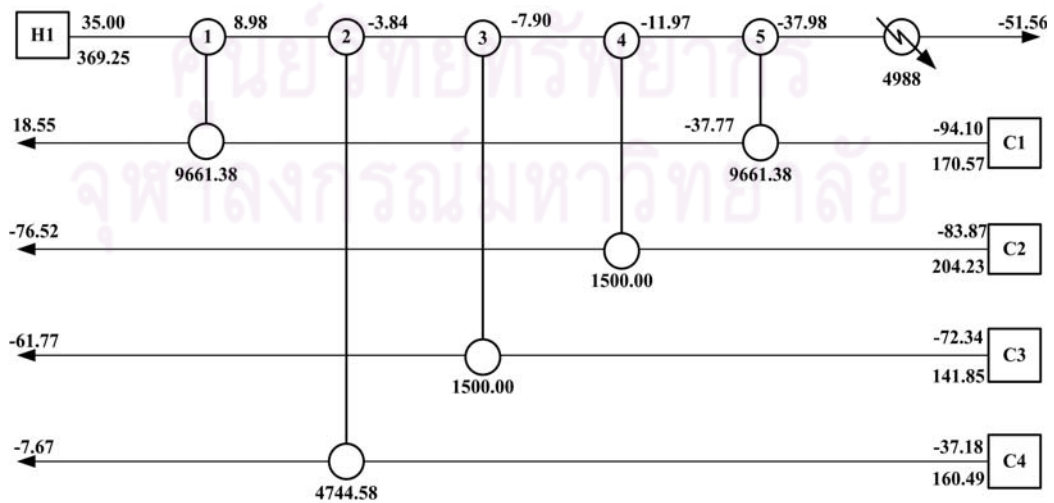

Figure 4.8: The heat exchanger network of Alternative 6, HEN-6

By using synthesis procedure that provided by Wongsri (1990), we can receive the resilient network from the synthesis tables as following Table 4.8.

Table 4.8: Synthesis Table for Alternative 6

Stream	Load	W	T1	T2	D1	D2	Action
a) State 1							
H1	30204.18	370.32	30.00	-51.56	3703.25	0.00	Selected B[C]
C1	18465.11	171.53	18.55	-89.10	0.00	1715.30	Selected
C2	1091.54	204.23	-76.52	-81.87	0.00	816.93	
C3	1216.30	141.85	-61.77	-70.34	0.00	567.40	
C4	4422.95	160.82	-7.67	-35.18	0.00	643.27	
b) State 2							
H1	20971.62	370.32	5.07	-51.56	3703.25	0.00	Selected B[C]
C1	9232.56	171.53	-35.27	-89.10	0.00	1715.30	
C2	1091.54	204.23	-76.52	-81.87	0.00	816.93	
C3	1216.30	141.85	-61.77	-70.34	0.00	567.40	
C4	4422.95	160.82	-7.67	-35.18	0.00	643.27	Selected
c) State 3							
H1	15905.41	370.32	-8.61	-51.56	4346.51	0.00	Selected B[C]
C1	9232.56	171.53	-35.27	-89.10	0.00	1715.30	
C2	1091.54	204.23	-76.52	-81.87	0.00	816.93	
C3	1216.30	141.85	-61.77	-70.34	0.00	567.40	Selected
d) State 4							
H1	14121.71	370.32	-13.43	-51.56	4913.92	0.00	Selected B[C]
C1	9232.56	171.53	-35.27	-89.10	0.00	1715.30	
C2	1091.54	204.23	-76.52	-81.87	0.00	816.93	Selected
e) State 5							
H1	12213.25	370.32	-18.58	-51.56	5730.84	0.00	Selected BK
C1	9232.56	171.53	-35.27	-89.10	0.00	1715.30	Selected
f) State 6							
H1	1265.39	370.32	-48.14	-51.56	7446.14	0.00	To Cooler

4.2.8 HEN Alternative 7

In previous chapter, the Alternative 7 can be written a simply heat exchanger network as following: See Figure 4.9.

There are five streams in the network. We can find the minimum utility requirements which equal 4988 MJ/hr of cold utilities.

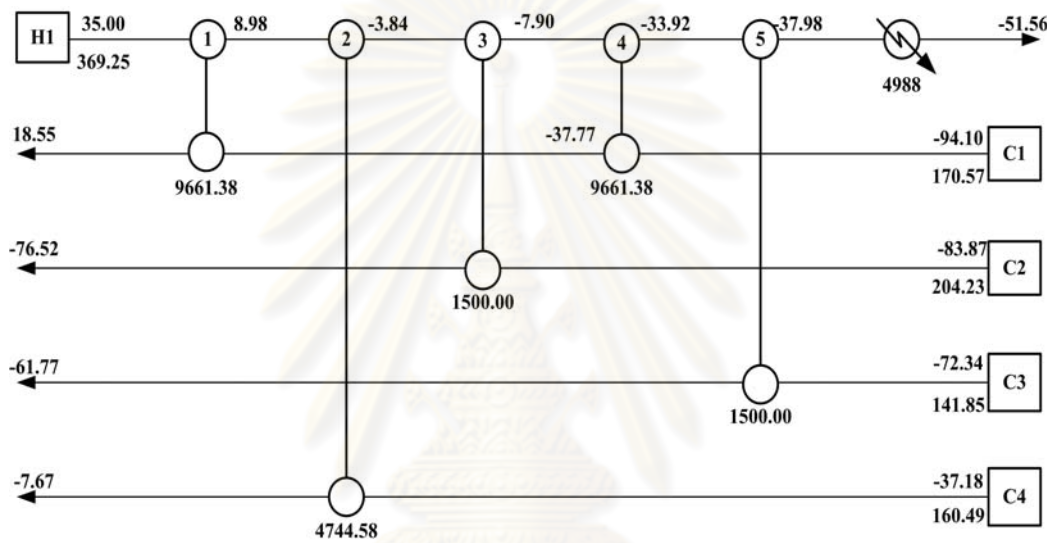

Figure 4.9: The heat exchanger network of Alternative 7, HEN-7

By using synthesis procedure that provided by Wongsri (1990), we can receive the resilient network from the synthesis tables as following Table 4.9.

Table 4.9: Synthesis Table for Alternative 7

Stream	Load	W	T1	T2	D1	D2	Action
a) State 1							
H1	30204.18	370.32	30.00	-51.56	3703.25	0.00	Selected B[C]
C1	18465.11	171.53	18.55	-89.10	0.00	1715.30	Selected
C2	1091.54	204.23	-76.52	-81.87	0.00	816.93	
C3	1216.30	141.85	-61.77	-70.34	0.00	567.40	
C4	4422.95	160.82	-7.67	-35.18	0.00	643.27	
b) State 2							

H1	20971.62	370.32	5.07	-51.56	3703.25	0.00	Selected B[C]
C1	9232.56	171.53	-35.27	-89.10	0.00	1715.30	
C2	1091.54	204.23	-76.52	-81.87	0.00	816.93	
C3	1216.30	141.85	-61.77	-70.34	0.00	567.40	
C4	4422.95	160.82	-7.67	-35.18	0.00	643.27	Selected
c) State 3							
H1	15905.41	370.32	-8.61	-51.56	4346.51	0.00	Selected B[C]
C1	9232.56	171.53	-35.27	-89.10	0.00	1715.30	
C2	1091.54	204.23	-76.52	-81.87	0.00	816.93	Selected
C3	1216.30	141.85	-61.77	-70.34	0.00	567.40	
d) State 4							
H1	13996.95	370.32	-13.76	-51.56	5163.44	0.00	Selected B[C]
C1	9232.56	171.53	-35.27	-89.10	0.00	1715.30	Selected
C3	1216.30	141.85	-61.77	-70.34	0.00	567.40	
e) State 5							
H1	3049.09	370.32	-43.33	-51.56	6878.74	0.00	Selected BK
C3	1216.30	141.85	-61.77	-70.34	0.00	567.40	Selected
f) State 6							
H1	1265.39	370.32	-48.14	-51.56	7446.14	0.00	To Cooler

4.2.9 HEN Alternative 8

In previous chapter, the Alternative 8 can be written a simply heat exchanger network as following: See Figure 4.10.

There are five streams in the network. We can find the minimum utility requirements which equal 4988 MJ/hr of cold utilities.

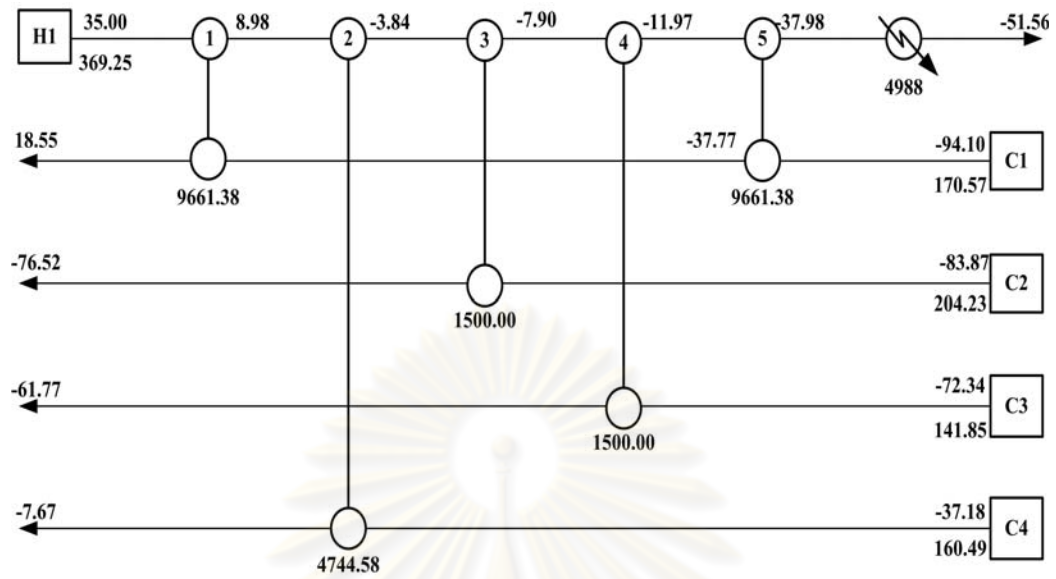

Figure 4.10: The heat exchanger network of Alternative 8, HEN-8

By using synthesis procedure that provided by Wongsri (1990), we can receive the resilient network from the synthesis tables as following Table 4.10.

Table 4.10: Synthesis Table for Alternative 8

Stream	Load	W	T1	T2	D1	D2	Action
a) State 1							
H1	30204.18	370.32	30.00	-51.56	3703.25	0.00	Selected B[C]
C1	18465.11	171.53	18.55	-89.10	0.00	1715.30	Selected
C2	1091.54	204.23	-76.52	-81.87	0.00	816.93	
C3	1216.30	141.85	-61.77	-70.34	0.00	567.40	
C4	4422.95	160.82	-7.67	-35.18	0.00	643.27	
b) State 2							
H1	20971.62	370.32	5.07	-51.56	3703.25	0.00	Selected B[C]
C1	9232.56	171.53	-35.27	-89.10	0.00	1715.30	
C2	1091.54	204.23	-76.52	-81.87	0.00	816.93	
C3	1216.30	141.85	-61.77	-70.34	0.00	567.40	
C4	4422.95	160.82	-7.67	-35.18	0.00	643.27	Selected
c) State 3							
H1	15905.41	370.32	-8.61	-51.56	4346.51	0.00	Selected B[C]

C1	9232.56	171.53	-35.27	-89.10	0.00	1715.30	
C2	1091.54	204.23	-76.52	-81.87	0.00	816.93	Selected
C3	1216.30	141.85	-61.77	-70.34	0.00	567.40	
d) State 4							
H1	13996.95	370.32	-13.76	-51.56	5163.44	0.00	Selected B[C]
C1	9232.56	171.53	-35.27	-89.10	0.00	1715.30	
C3	1216.30	141.85	-61.77	-70.34	0.00	567.40	Selected
e) State 5							
H1	12213.25	370.32	-18.58	-51.56	5730.84	0.00	Selected BK
C1	9232.56	171.53	-35.27	-89.10	0.00	1715.30	Selected
f) State 6							
H1	1265.39	370.32	-48.14	-51.56	7446.14	0.00	To Cooler

4.3 Testing the Networks

For testing the networks, the simulations for control are not need. Therefore, we need the disturbance propagation technique to design the path of tolerates disturbance and used the control structure design method (Kunlawaniteewat, 2002) to install the control loops into the networks for eradicated the variations. Because eradicated the variations into utilities is more powerful and take less effected in temperatures of the streams that exchanged. The Figure 4.11-4.26 will show the process flowchart, the disturbance load propagation and the path of the variation into a cold utility for all resilient networks by using bypass of heat exchanger controlling the target temperature.

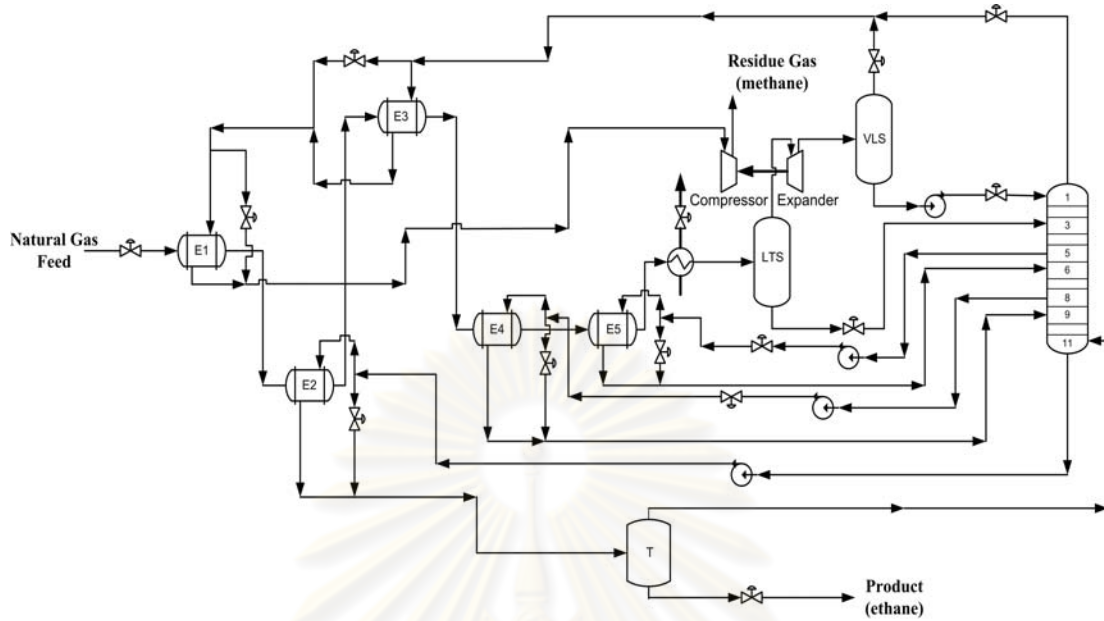

Figure 4.11: The Process Flowchart for Alternative 1

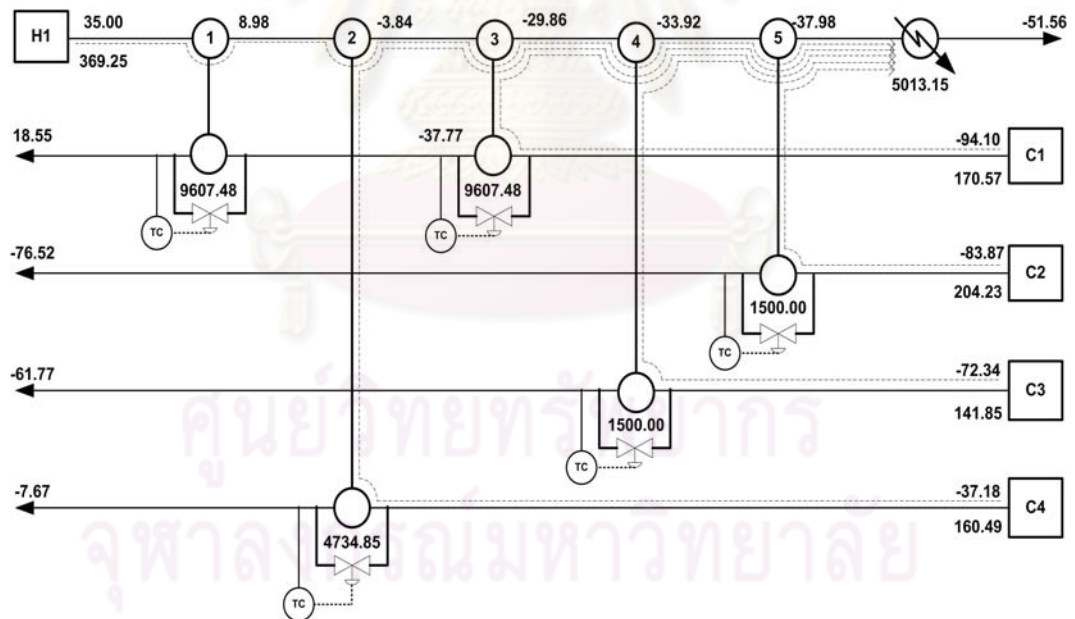

Figure 4.12: The Process Flowchart for Alternative 1

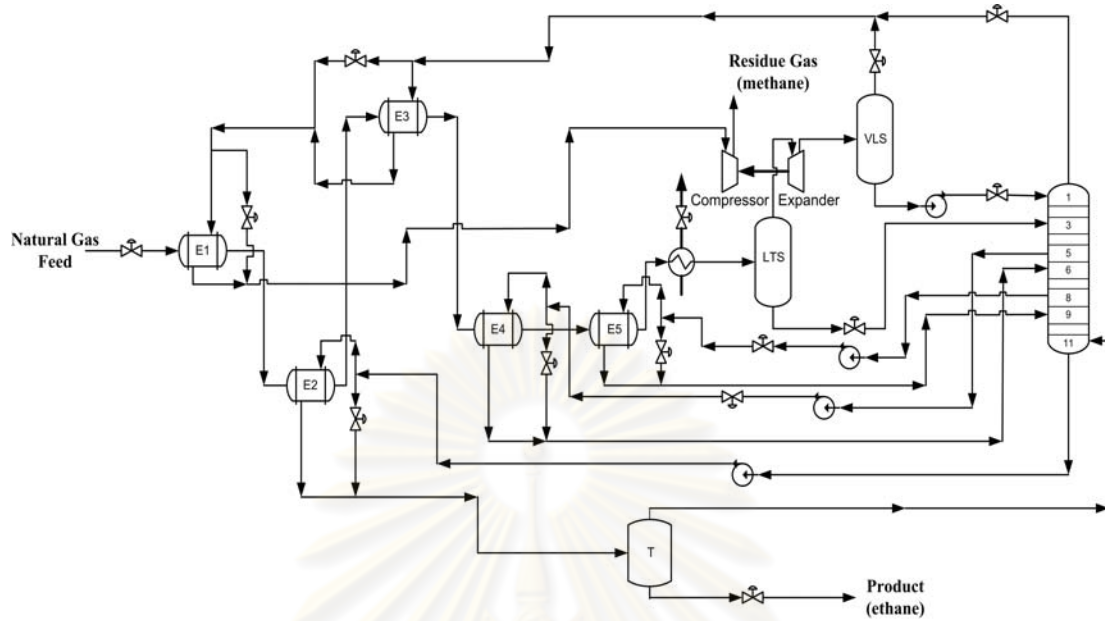

Figure 4.13: The Process Flowchart for Alternative 2

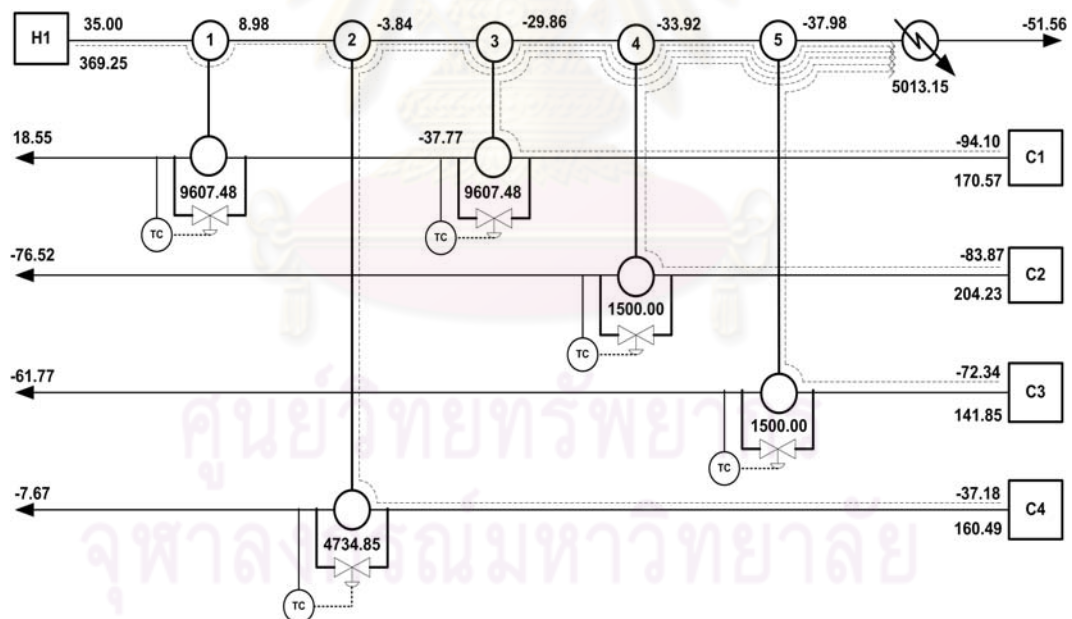

Figure 4.14: The Process Flowchart for Alternative 2

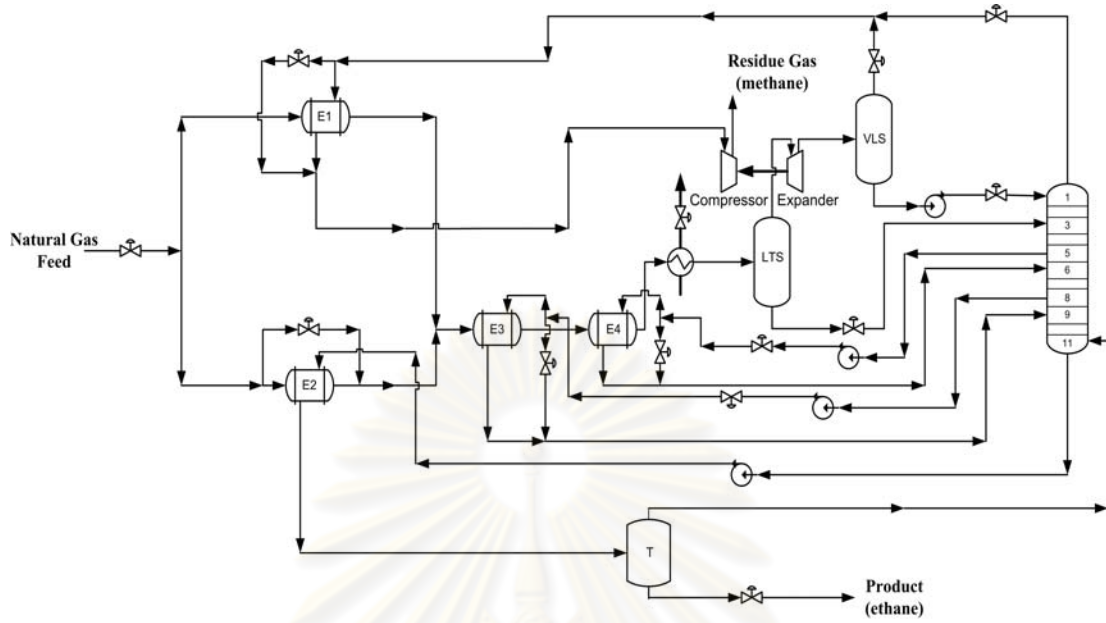

Figure 4.15: The Process Flowchart for Alternative 3

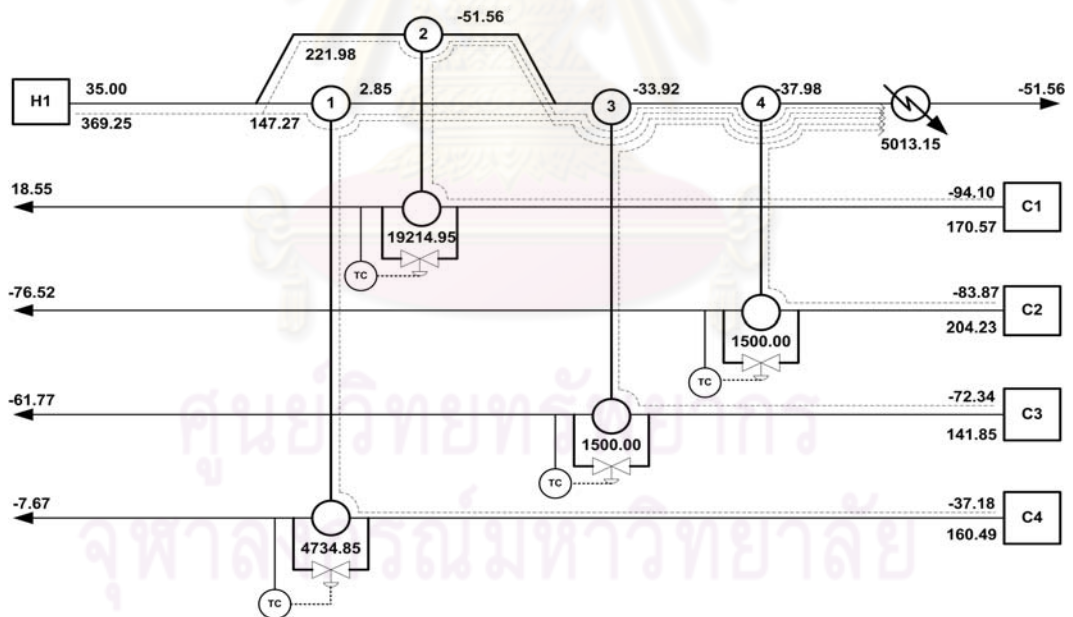

Figure 4.16: The Process Flowchart for Alternative 3

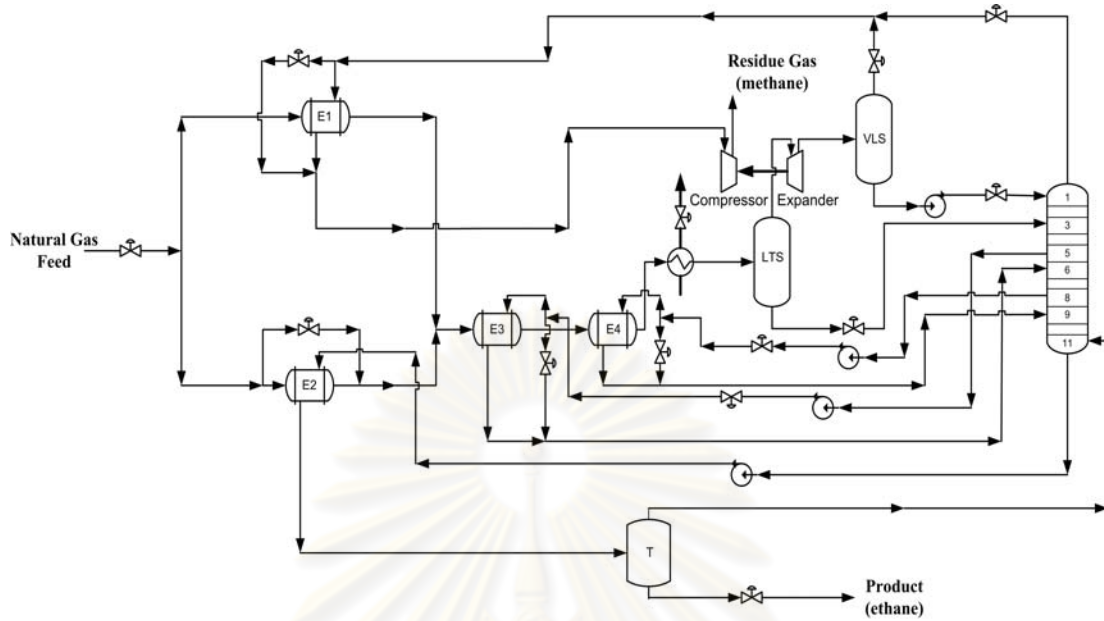

Figure 4.17: The Process Flowchart for Alternative 4

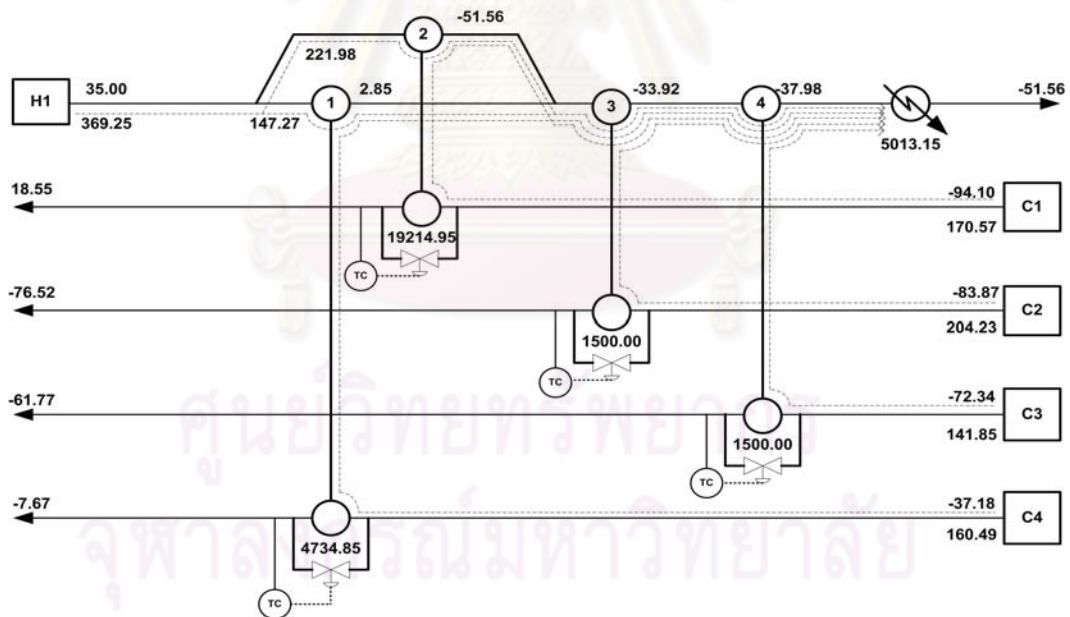

Figure 4.18: The Process Flowchart for Alternative 4

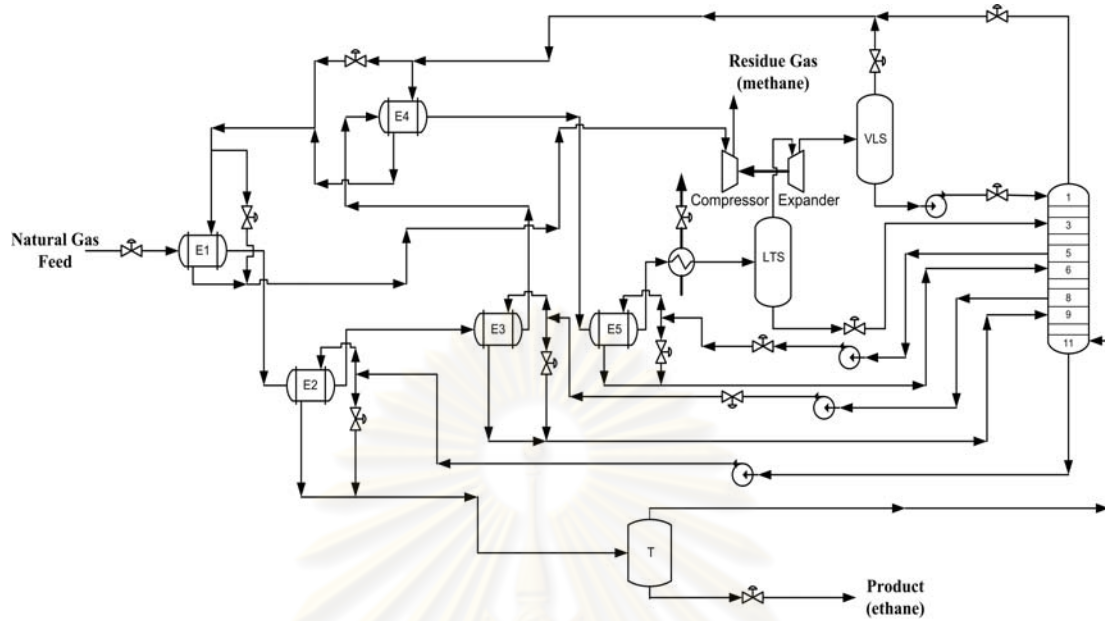

Figure 4.19: The Process Flowchart for Alternative 5

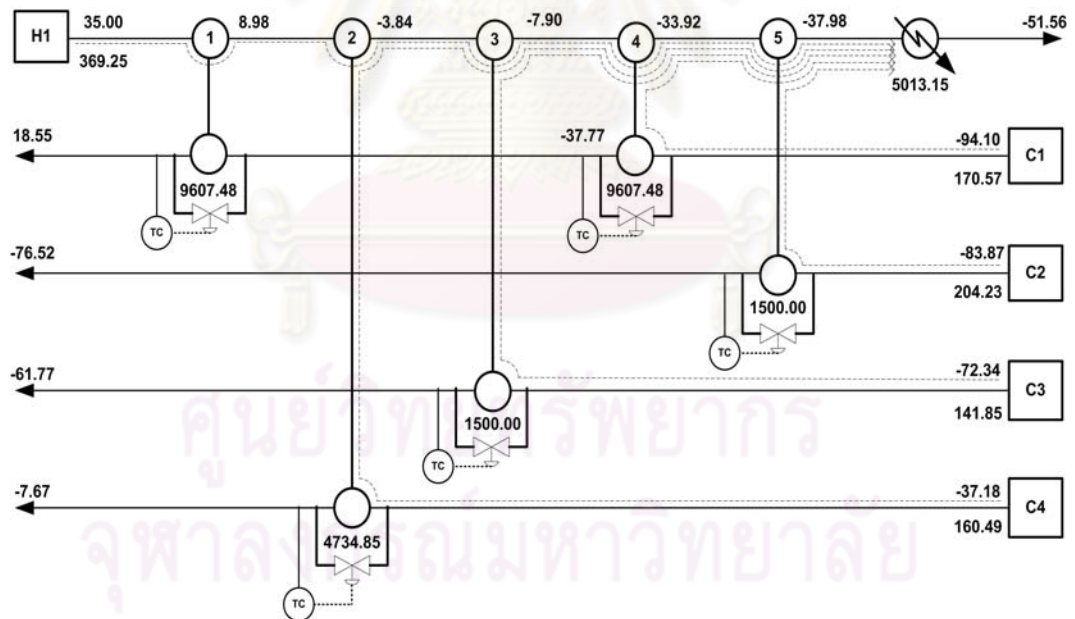

Figure 4.20: The Process Flowchart for Alternative 5

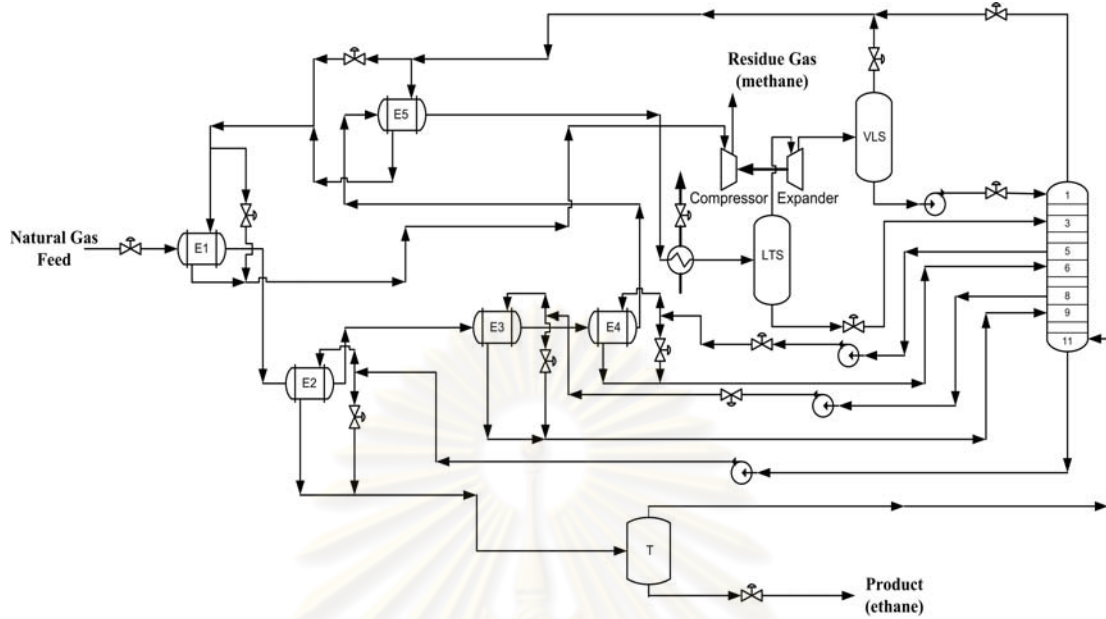

Figure 4.21: The Process Flowchart for Alternative 6

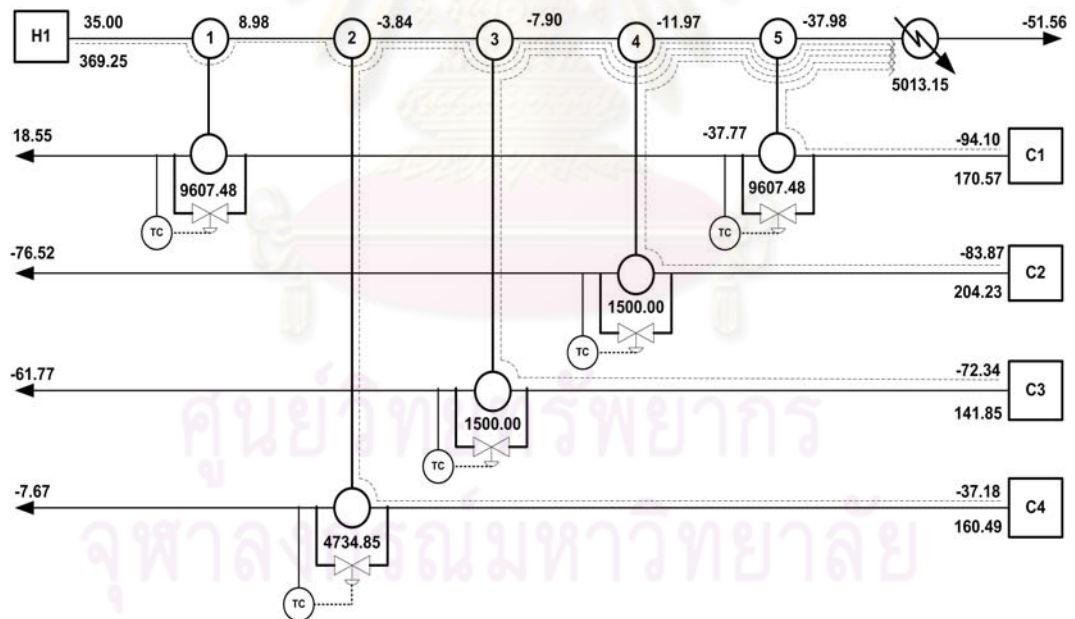

Figure 4.22: The Process Flowchart for Alternative 6

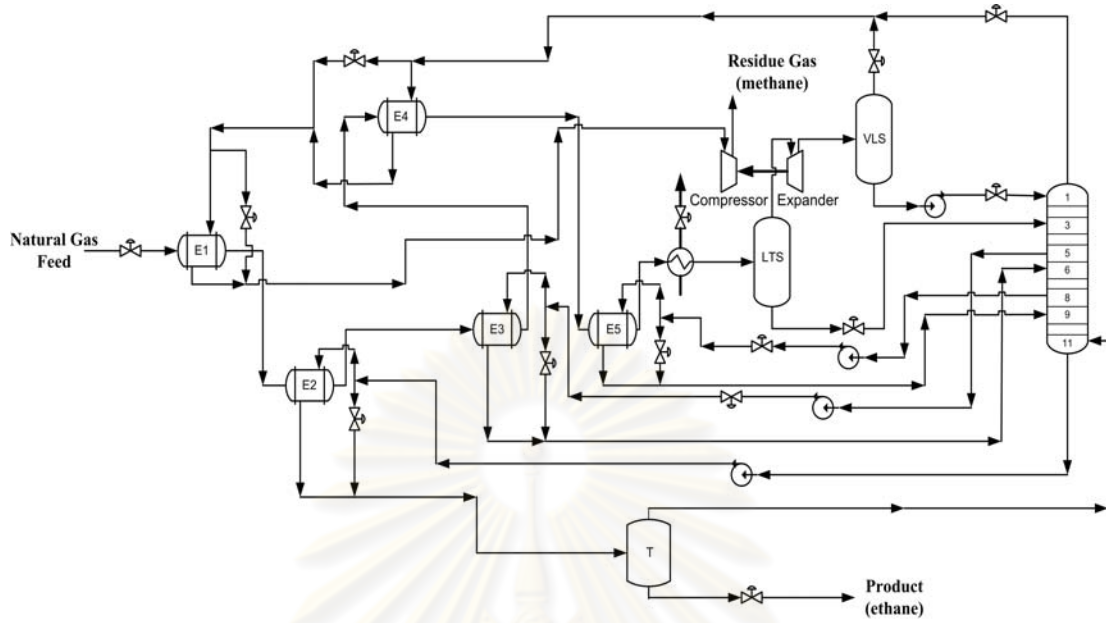

Figure 4.23: The Process Flowchart for Alternative 7

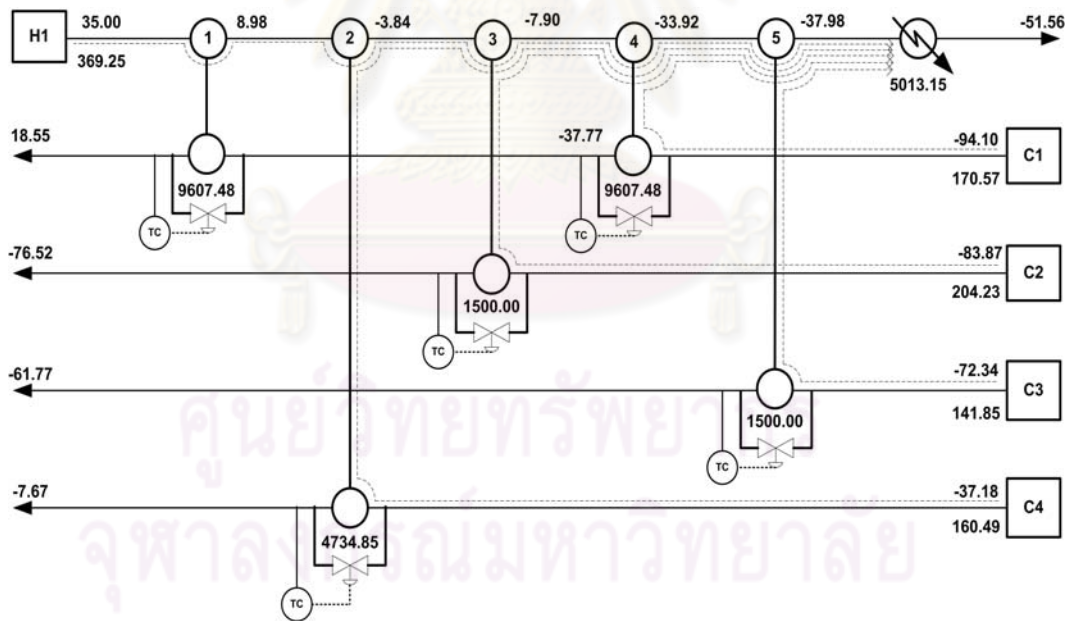

Figure 4.24: The Process Flowchart for Alternative 7

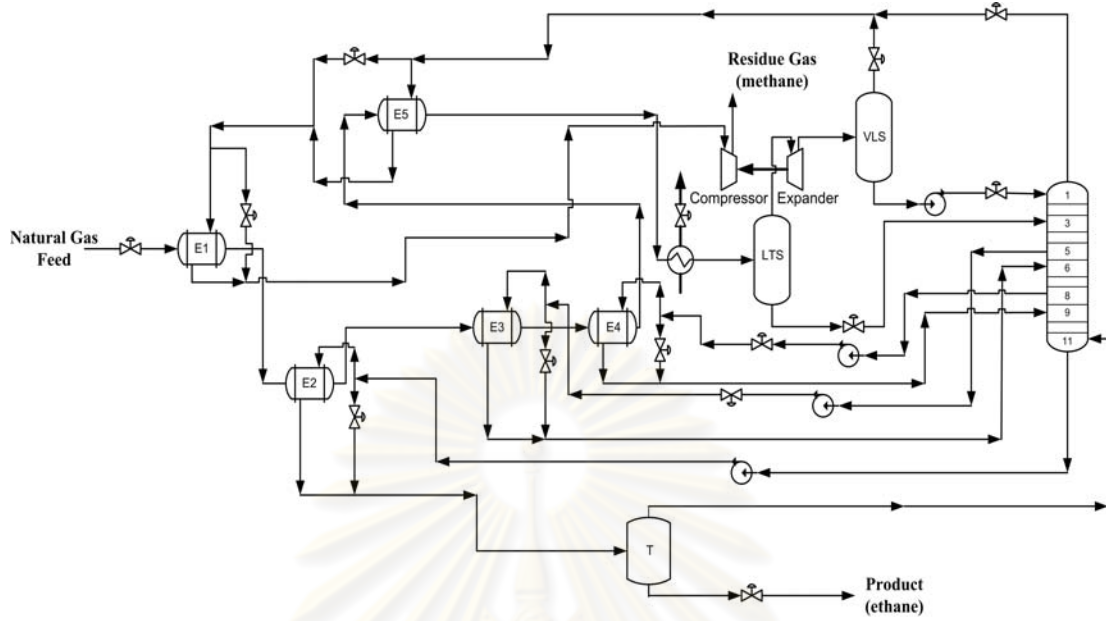

Figure 4.25: The Process Flowchart for Alternative 8

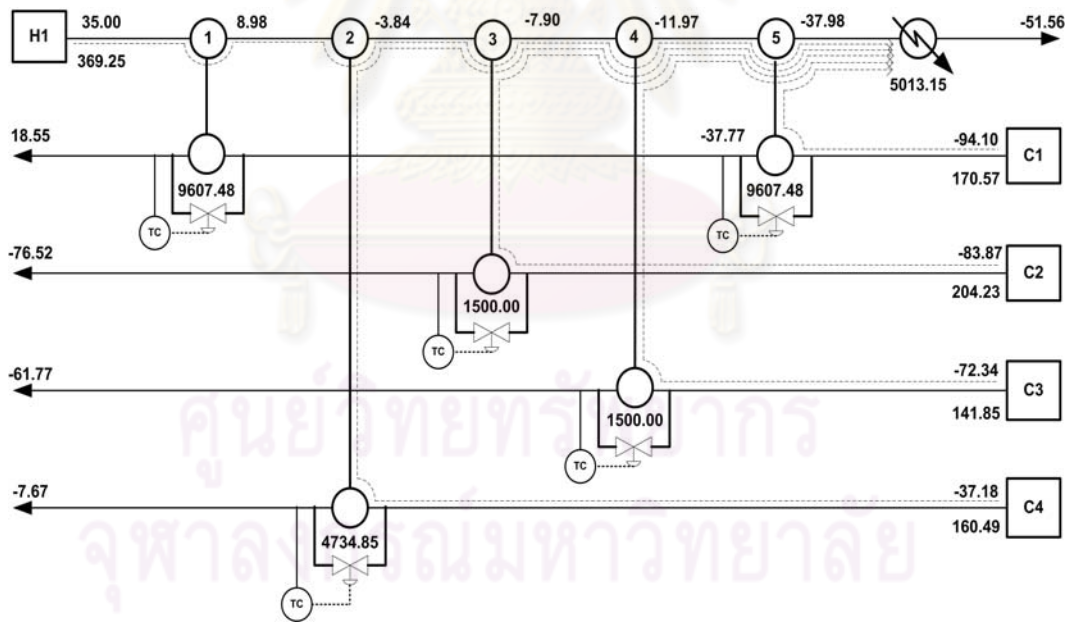

Figure 4.26: The Process Flowchart for Alternative 8

CHAPTER V

CONTROL STRUCTURE DESIGN AND DYNAMIC SIMULATION

Maintaining the plant energy and mass balances are the essential task of plantwide for a complex plant consists of recycle streams and energy integration when the disturbance load come through the process. The control system is needed to reject loads and regulate an entire process into a design condition to achieve its objectives therefore our purpose of this chapter is to present the new control structures of energy integrated process. Moreover, the three designed control structures are also compared between base case and alternatives of the TEP based on rigorous dynamic simulation by using the commercial software HYSYS.

5.1 Plantwide Control Strategies

The plantwide control structures can be applied to the modules. Here, the nine-step approach of Luyben (1999) and Fixture point theorem (Wongsri, 2008) are selected for demonstration on each of the TEP module and discussed below.

5.1.1 Nine-step approach of Luyben

This approach is used to design the first control structure of the TEP and we will use this control structure to design the continue control structure. The approach discussed below.

Step1. Establish Control Objectives

For this process, the control objectives are to control the impurity of methane in the ethane product at 5.67 mole% based on the steady state base case operating conditions (Akman and Konukman, 2005).

Step2. Determine Control Degree of Freedom

The base case for a natural gas expander plant has 13 control degrees of freedom; 4 utility streams, 1 expander power and 8 control valves. For Alt1, Alt2 Alt5, Alt6, Alt7 and Alt8, there are 15 control degrees of freedom; 1 utility stream, 1 expander power and 13 control valves. For Alt3 and Alt4, there are 14 control degrees of freedom; 1 utility stream, 1 expander power and 12 control valves.

Step3. Establish Energy management system

The hot natural gas feed stream must be removed to decrease temperature and separate compositions. Before the natural gas will enter separation units, it must be dissipated to utility cooler to take a low enough temperature for separation. To ensure heat removal from the process, we must control LTS inlet temperature with the cooler. Furthermore, the energy management can make the path of disturbance load propagation to the separation section.

Step4. Set Production Rate

This process has no reaction sections. So, the production rate setting can be made by level control in the reboiler and control of the natural gas feed. These controls are the production rate setting indirectly.

Step5. Control Product Quality and Handle Safety, Operational, and Environmental

To control the impurity of methane in the ethane product, the reboiler

heat duties is chosen. For the DT in this plant, there are two points of energy entering the tray temperature directly (tray-6 and tray-9 of the DT). The control of impurity of methane in the ethane product can make at these tray in the DT. Therefore, we will control tray-6 and tray-9 temperature in the DT as well. The completion of this step satisfies all of the control objectives for the DT.

Step6. Control Inventories and Fix a Flow in Every Recycle Loop

The natural gas expander plant has no recycle material stream. So, we are not interest the recycle loop. For this step, we consider the inventory control. The most inventory control will concern with level and pressure of the units in the process. In this process, three pressures and three liquid levels must be controlled. For the pressures, there are two separators and one distillation column. The vapor overhead flow of these units is used to control pressure at each unit. For the liquid levels, there are one reboiler of the DT and two separators. The most direct way to control separator level and reboiler level is the liquid bottom flow leaving the separator and reboiler, respectively.

Step7. Check Component Balances

Material balance on each component showed no accumulation of any component in the system. It is not difficult to establish that every component within the system has a means by which to exit the system.

Step8. Control Individual Unit Operations

The pressure in the columns and separators should be controlled. For this process, the interest choice consists of the DT top valve (control DT pressure), expander power (control LTS pressure) and overhead VLS valve (control VLS pressure). Nevertheless, LTS, VLS and reboiler levels should be controlled by using bottom valve of these.

Step9. Optimize Economics or Improve Dynamic Controllability

This step is not considered in this work.

5.1.2 Fixture Point Theorem

For the second and third control structure, we use the Fixture point theorem (Wongsri, 2008). These control structures will be designed by using the first control structure from Luyben's heuristic. The fixture point theorem is provided by Wongsri, 2008 to define the controlled variable which is the most sensitivity. Defined control variable should consider to control and pair with manipulated variable (MV) in the first.

Fixture point theorem analysis:

1. The process is considered at dynamic mode of simulation until it reaches to steady state.
2. Controlled variable (CV) can be arranged to follow the most sensibility of the process variable by step change the MV (change only one MV, the other should be fixed then alternate to other until complete). Study the magnitude of integral absolute error (IAE) of all process variables that deviates from steady state. This thesis considers six process variables including temperature, pressure, flow rate, composition, tank level and stage temperature.
3. Consider CV that give the most deviation from steady state (high IAE score) to match with MV, after that will consider the next CV to match with other MV.

5.2 Design of Plantwide Control Structure

In this work, we apply the nine steps of the plantwide control structure (Luyben, 1998) to design control structure for the TEP process. The first control

structure (CS1) is design by using these steps. The second and third control structure (CS2 and CS3) will be designed by using the Fixture point theorem (Wongsri, 2008). The control structures of alternatives are similar to base case but their networks are different. In the networks, the base case uses utility heat exchanger but the alternatives use the process-to-process heat exchanger. Therefore, in the networks, the manipulated variables of base case is different with alternatives, which base case uses utility but alternatives use the bypass valve of heat exchanger as the manipulated variables. The objectives for this process listed below:

1. Maintain process variable at desired values
2. Keep process operating conditions within equipment constraints
3. Minimize variability of the product rate and the product quality during disturbance
4. Minimize the disturbance propagation

In all of these control structures (CS1, CS2 and CS3), the same loops are used as follows:

- Valve V1 is manipulated to control the natural gas feed molar flow.
- Valve V2 is manipulated to control the low temperature separator (LTS) level.
- Valve V3 is manipulated to control the vapor liquid separator (VLS) level.
- Valve V4 is manipulated to control the vapor liquid separator (VLS) vessel pressure.
- Valve V5 is manipulated to control the demethanizer tower (DT) overhead pressure.
- Expander power is manipulated to control the VLS vessel pressure.
- Cooler duty is manipulated to control the LTS inlet temperature.

5.2.1 Design of control structures for the TEP base case

For the base case of the TEP, CS1 control structure, shown in Figure 5.1, is designed by using the nine steps of the plantwide control structure of Luyben (1998). The CS2 and CS3 control structure, shown in Figure 5.2 and 5.3, respectively, is designed by using the Fixture point theorem (Wongsri, 2008). The same loops of these control structures are used as follows:

- Valve V6 is manipulated to control the E2 cold-outlet temperature.
- Valve V7 is manipulated to control the E1 cold-outlet temperature.
- Heat duty of exchanger E-104 is manipulated to control the DT tray-6 temperature.
- Heat duty of exchanger E-102 is manipulated to control the DT tray-9 temperature.

For the CS1 control structure, the impurity of methane in the ethane product is controlled by manipulating the heat duty of exchanger E-101 (or DT reboiler duty). The DT base level is controlled by manipulating the DT bottom valve (V8).

For the CS2 control structure, the impurity of methane in the ethane product is not controlled but it will be controlled by controlling the temperature at bottom tray in DT. The DT bottom tray temperature and DT base level are controlled by manipulating the DT bottom valve (V8) and heat duty of exchanger E-101, respectively.

The CS3 control structure develops from CS1 control structure with cascade control between methane impurity in the product and DT bottom tray temperature. The cascade control is used to improve control system performance and ensure the disturbance in the process. The cascade control is controlled by manipulating the heat duty of exchanger E-101. The DT base level is controlled by manipulating the DT bottom valve (V8).

The control structure and controller parameter for CS1, CS2 and CS3 control structures are given in Table 5.1. The P controllers are employed for level loops, PI controllers for the pressure and flow loops and PID controllers for temperature and composition loops.

5.2.2 Design of Control Structures for the TEP Alternative 1

For the alternative 1 of the TEP, CS1, CS2 and CS3 control structure show in Figure 5.4, 5.5 and 5.6, respectively. Their control structures are similar to control structures of the base case alternative but its network is different. The same loops of these control structures in the alternative 1 are used as follows:

- Valve V6 is manipulated to control the E3 cold-outlet temperature.
- Valve V7 is manipulated to control the E1 cold-outlet temperature.
- Valve V9 is manipulated to control the tray-5 side stream flow rate.
- Valve V10 is manipulated to control the DT tray-6 temperature.
- Valve V11 is manipulated to control the tray-8 side stream flow rate.
- Valve V12 is manipulated to control the DT tray-9 temperature.

For the CS1 control structure, the impurity of methane in the ethane product is controlled by manipulating the bypass cold stream valve (V13) of exchanger E2. The DT base level is controlled by manipulating the DT bottom valve (V8).

For the CS2 control structure, the impurity of methane in the ethane product is not controlled but it will be controlled by controlling the temperature at bottom tray in DT. The DT bottom tray temperature and DT base level are controlled by manipulating the DT bottom valve (V8) and bypass cold stream valve (V13) of exchanger E2, respectively.

The CS3 control structure develops from CS1 control structure with cascade control between methane impurity in the product and DT bottom tray temperature. The cascade control is used to improve control system performance and ensure the disturbance in the process. The cascade control is controlled by manipulating the bypass cold stream valve (V13) of exchanger E2. The DT base level is controlled by manipulating the DT bottom valve (V8).

The control structure and controller parameter for CS1, CS2 and CS3 control structure are given in Table 5.2. The P controllers are employed for level loops, PI controllers for the pressure and flow loops and PID controllers for temperature and composition loops.

5.2.3 Design of Control Structures for the TEP Alternative 2

For the alternative 2 of the TEP, CS1, CS2 and CS3 control structure show in Figure 5.7, 5.8 and 5.9, respectively. Their control structures are similar to control structures of the alternative 1. In the different networks between Alt2 and Alt 1, the network of alternative 2 will exchange between side stream tray-5 and hot natural gas after exchanger E3, and before side stream tray-8 will exchange. The same loops of these control structures are similar to alternative 1. All of the control structures in this alternative are similar to the alternative 1.

The control structure and controller parameter for CS1, CS2 and CS3 control structure are given in Table 5.3. The P controllers are employed for level loops, PI controllers for the pressure and flow loops and PID controllers for temperature and composition loops.

5.2.4 Design of Control Structures for the TEP Alternative 3

For the alternative 3 of the TEP, CS1, CS2 and CS3 control structure show in Figure 5.10, 5.11 and 5.12, respectively. Their control structures are similar to control structures of the alternative 1. In the different networks between Alt3 and Alt 1, the network of alternative 3 will have 4 heat exchangers and stream splitting to match the cold stream. The same loops of these control structures are similar to alternative 1 but it will not have the exchanger E3 for above.

For the CS1 control structure, the impurity of methane in the ethane product is controlled by manipulating the bypass hot stream valve (V13) of exchanger E2. The DT base level is controlled by manipulating the DT bottom valve (V8).

For the CS2 control structure, the impurity of methane in the ethane product is not controlled but it will be controlled by controlling the temperature at bottom tray in DT. The DT bottom tray temperature and DT base level are controlled by manipulating the DT bottom valve (V8) and bypass hot stream valve (V13) of exchanger E2, respectively.

The CS3 control structure develops from CS1 control structure with cascade control between methane impurity in the product and DT bottom tray temperature. The cascade control is used to improve control system performance and ensure the disturbance in the process. The cascade control is controlled by manipulating the bypass hot stream valve (V13) of exchanger E2. The DT base level is controlled by manipulating the DT bottom valve (V8).

The control structure and controller parameter for CS1, CS2 and CS3 control structure are given in Table 5.4. The P controllers are employed for level loops, PI controllers for the pressure and flow loops and PID controllers for temperature and composition loops.

5.2.5 Design of Control Structures for the TEP Alternative 4

For the alternative 4 of the TEP, CS1, CS2 and CS3 control structure show in Figure 5.13, 5.14 and 5.15, respectively. Their control structures are similar to control structures of the alternative 3. In the different networks between Alt4 and Alt 3, the network of alternative 4 will exchange between side stream tray-5 and hot natural gas after exchanger E1 and E2, and before side stream tray-8 will exchange. The same loops of these control structures are similar to alternative 3. All of the control structures in this alternative are similar to the alternative 3.

The control structure and controller parameter for CS1, CS2 and CS3 control structure are given in Table 5.5. The P controllers are employed for level loops, PI controllers for the pressure and flow loops and PID controllers for temperature and composition loops.

5.2.6 Design of Control Structures for the TEP Alternative 5

For the alternative 5 of the TEP, CS1, CS2 and CS3 control structure show in Figure 5.16, 5.17 and 5.18, respectively. Their control structures are similar to control structures of the alternative 1. In the different networks between Alt5 and Alt 1, the network of alternative 5 will exchange between side stream tray-8 and hot natural gas after exchanger E2, and before methane residue gas stream will exchange. The same loops of these control structures are similar to alternative 1. All of the control structures in this alternative are similar to the alternative 1.

The control structure and controller parameter for CS1, CS2 and CS3 control structure are given in Table 5.6. The P controllers are employed for level loops, PI controllers for the pressure and flow loops and PID controllers for temperature and composition loops.

5.2.7 Design of Control Structures for the TEP Alternative 6

For the alternative 6 of the TEP, CS1, CS2 and CS3 control structure show in Figure 5.19, 5.20 and 5.21, respectively. Their control structures are similar to control structures of the alternative 5. In the different networks between Alt 6 and Alt 5, the network of alternative 6 will exchange between side stream tray-5 and hot natural gas after exchanger E3 (cold side stream tray-8 exchange hot natural gas), and before methane residue gas stream will exchange. The same loops of these control structures are similar to alternative 5. All of the control structures in this alternative are similar to the alternative 5.

The control structure and controller parameter for CS1, CS2 and CS3 control structure are given in Table 5.7. The P controllers are employed for level loops, PI controllers for the pressure and flow loops and PID controllers for temperature and composition loops.

5.2.8 Design of Control Structures for the TEP Alternative 7

For the alternative 7 of the TEP, CS1, CS2 and CS3 control structure show in Figure 5.22, 5.23 and 5.24, respectively. Their control structures are similar to control structures of the alternative 2. In the different networks between Alt7 and Alt 2, the network of alternative 7 will exchange between side stream tray-5 and hot natural gas after exchanger E2, and before methane residue gas stream will exchange. The same loops of these control structures are similar to alternative 2. All of the control structures in this alternative are similar to the alternative 2.

The control structure and controller parameter for CS1, CS2 and CS3 control structure are given in Table 5.8. The P controllers are employed for level loops, PI controllers for the pressure and flow loops and PID controllers for

temperature and composition loops.

5.2.9 Design of Control Structures for the TEP Alternative 8

For the alternative 8 of the TEP, CS1, CS2 and CS3 control structure show in Figure 5.19, 5.20 and 5.21, respectively. Their control structures are similar to control structures of the alternative 7. In the different networks between Alt 8 and Alt 7, the network of alternative 8 will exchange between side stream tray-8 and hot natural gas after exchanger E3 (cold side stream tray-5 exchange hot natural gas), and before methane residue gas stream will exchange. The same loops of these control structures are similar to alternative 7. All of the control structures in this alternative are similar to the alternative 7.

The control structure and controller parameter for CS1, CS2 and CS3 control structure are given in Table 5.9. The P controllers are employed for level loops, PI controllers for the pressure and flow loops and PID controllers for temperature and composition loops.

Table 5.1: Control Structure and Controller Parameter for the TEP Base Case: Control Structure 1 (CS1), Control Structure 2 (CS2) and Control Structure 3 (CS3)

Controller	controlled variable	manipulated variable		Type	Kc	Ti	Td
FC.in	natural gas feed	natural gas feed valve (V1)		PI	0.5	0.3	-
LC.LTS	LTS liquid level	LTS bottom valve (V2)		P	2	-	-
PC.LTS	LTS pressure	expander power (E-100)		PI	2	10	-
LC.VLS	VLS liquid level	VLS bottom valve (V3)		P	2	-	-
PC.VLS	VLS pressure	VLS overhead valve (V4)		PI	2	10	-
TC.E1	E1 cold-outlet temp	E1 bypass cold stream valve (V7)		PID	4.022	0.312	0.069
TC.E2	E2 cold-outlet temp	E2 bypass cold stream valve (V6)		PID	4.019	0.309	0.069
TC.cooler	LTS inlet temperature	heat duty of exchanger E-103		PID	4.381	0.307	0.068
PC.dist	DT overhead pressure	DT overhead valve (V5)		PI	2	10	-
LC.reb	DT reboiler liquid level	CS1	DT bottom valve (V8)	P	2	-	-
		CS2	heat duty of exchanger E-101	P	1.5	-	-
TC.stage6	DT tray-6 temperature	heat duty of exchanger E-104		PID	5.126	1.694	0.377
TC.stage9	DT tray-9 temperature	heat duty of exchanger E-102		PID	3.630	1.954	0.434
CC.21	DT bottom methane mole fraction	CS1	heat duty of exchanger E-101	PID	0.861	5.366	1.192
		CS3	TC.bottom	PID	0.428	4.768	1.060
TC.bottom	DT bottom temperature	CS2	DT bottom valve (V8)	PID	2.768	4.730	1.051
		CS3	heat duty of exchanger E-101	PID	1.474	3.095	0.688

ศูนย์วิทยทรัพยากร
จุฬาลงกรณ์มหาวิทยาลัย

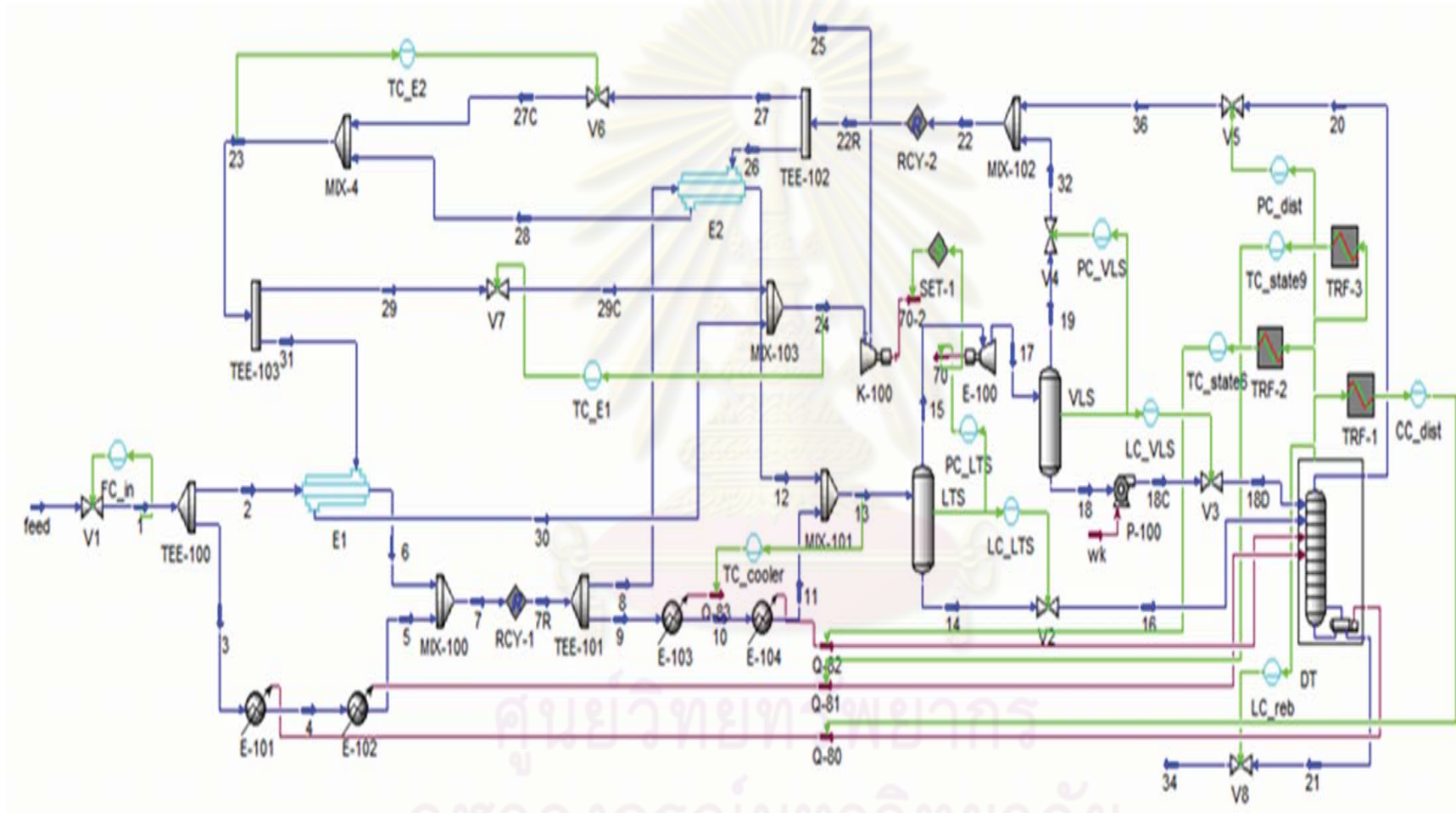

Figure 5.1: Application of the control structure 1 (CS1) to the TEP (Base Case)

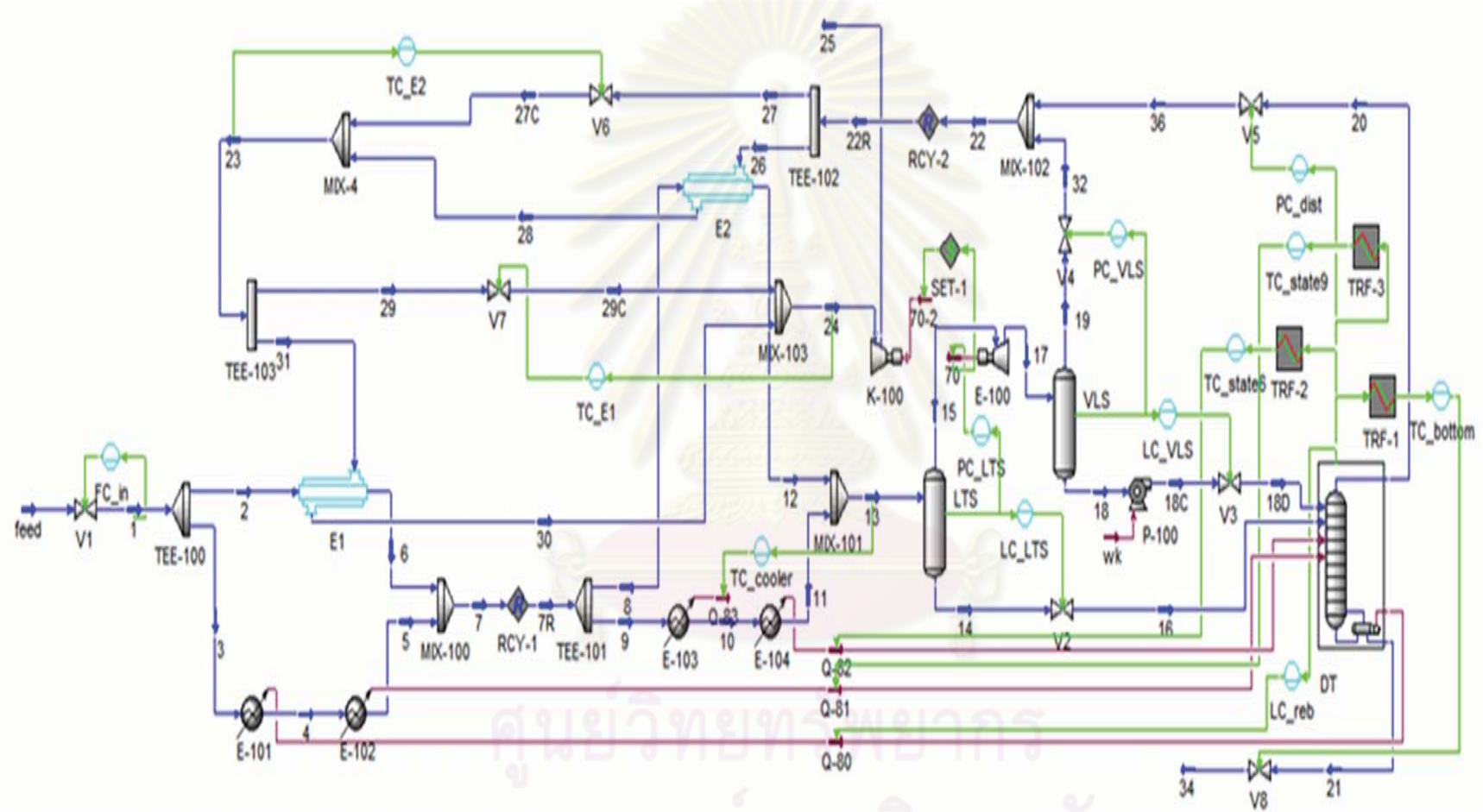

Figure 5.2: Application of the control structure 2 (CS2) to the TEP (Base Case)

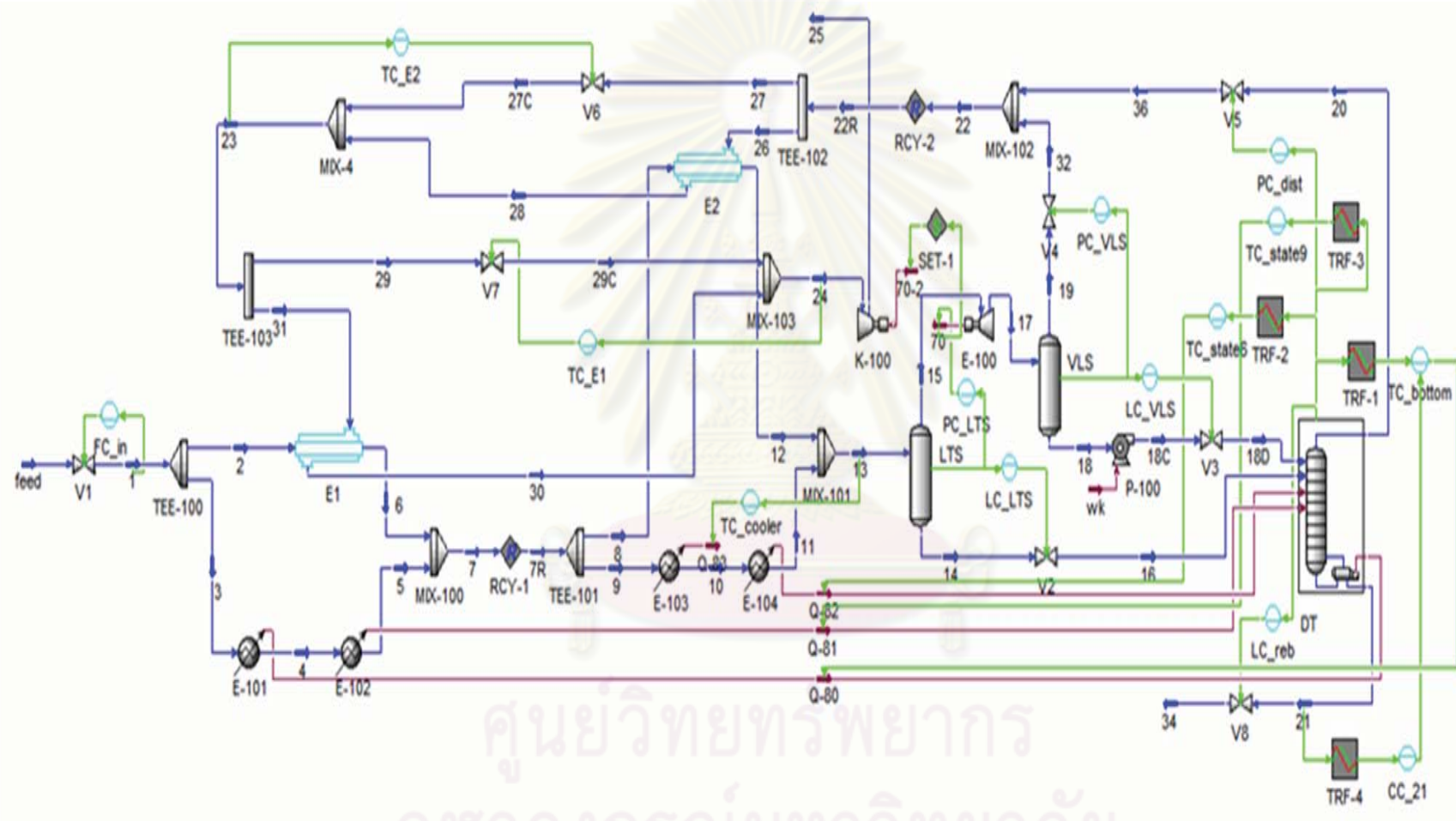

Figure 5.3: Application of the control structure 3 (CS3) to the TEP (Base Case)

Table 5.2: Control Structure and Controller Parameter for the TEP Alternative 1: Control Structure 1 (CS1), Control Structure 2 (CS2) and Control Structure 3 (CS3)

Controller	controlled variable	manipulated variable		Type	Kc	Ti	Td
FC_in	natural gas feed	natural gas feed valve (V1)		PI	0.5	0.3	-
LC_LTS	LTS liquid level	LTS bottom valve (V2)		P	2	-	-
PC_LTS	LTS pressure	expander power (E-100)		PI	2	10	-
LC_VLS	VLS liquid level	VLS bottom valve (V3)		P	2	-	-
PC_VLS	VLS pressure	VLS overhead valve (V4)		PI	2	10	-
TC_E1	E1 cold-outlet temp	E1 bypass cold stream valve (V7)		PID	3.730	0.320	0.071
TC_E3	E3 cold-outlet temp	E3 bypass cold stream valve (V6)		PID	3.622	0.212	0.047
TC_cooler	LTS inlet temperature	heat duty of exchanger E6		PID	4.206	0.318	0.071
PC_dist	DT overhead pressure	DT overhead valve (V5)		PI	2	10	-
LC_reb	DT base level	CS1	DT base valve (V8)	P	2	-	-
		CS2	E2 bypass cold stream valve (V13)	P	1.5	-	-
FC_stage5	Tray-5 side stream flow rate	Tray-5 side stream valve (V9)		PI	0.3502	0.0084	-
TC_stage6	DT tray-6 temperature	E5 bypass cold stream valve (V10)		PID	26.518	1.337	0.297
FC_stage8	Tray-8 side stream flow rate	Tray-8 side stream valve(V11)		PI	0.3796	0.0083	-
TC_stage9	DT tray-9 temperature	E4 bypass cold stream valve (V12)		PID	11.438	1.907	0.424
CC_21	DT bottom methane mole fraction	CS1	E2 bypass cold stream valve (V13)	PID	5.285	4.020	0.893
		CS3	TC_bottom	PID	2.457	4.552	1.011
TC_bottom	DT bottom temperature	CS2	DT base valve (V8)	PID	10.924	1.853	0.412
		CS3	E2 bypass cold stream valve (V13)	PID	10.730	1.777	0.395

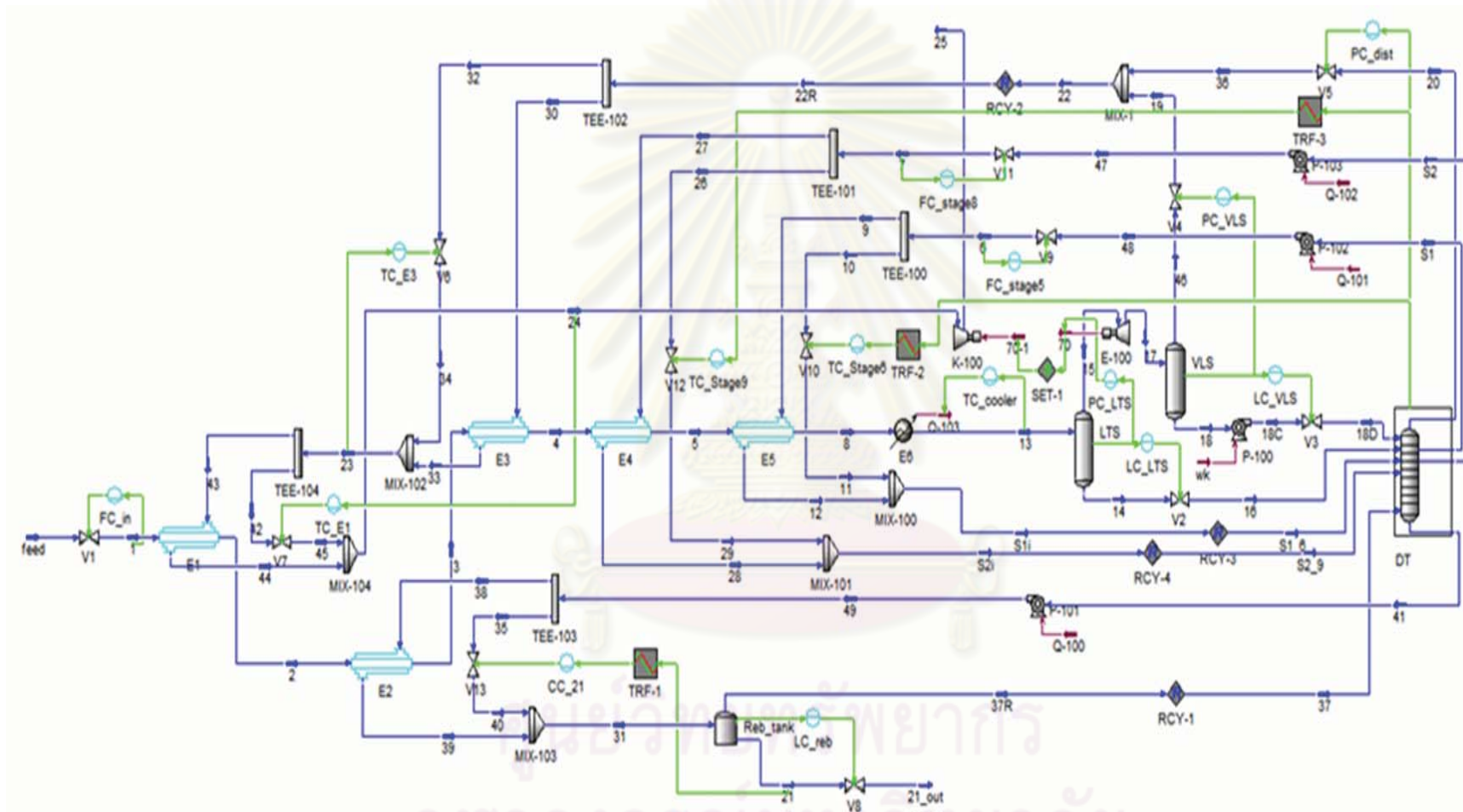

Figure 5.4: Application of the control structure 1 (CS1) to the TEP Alternative 1

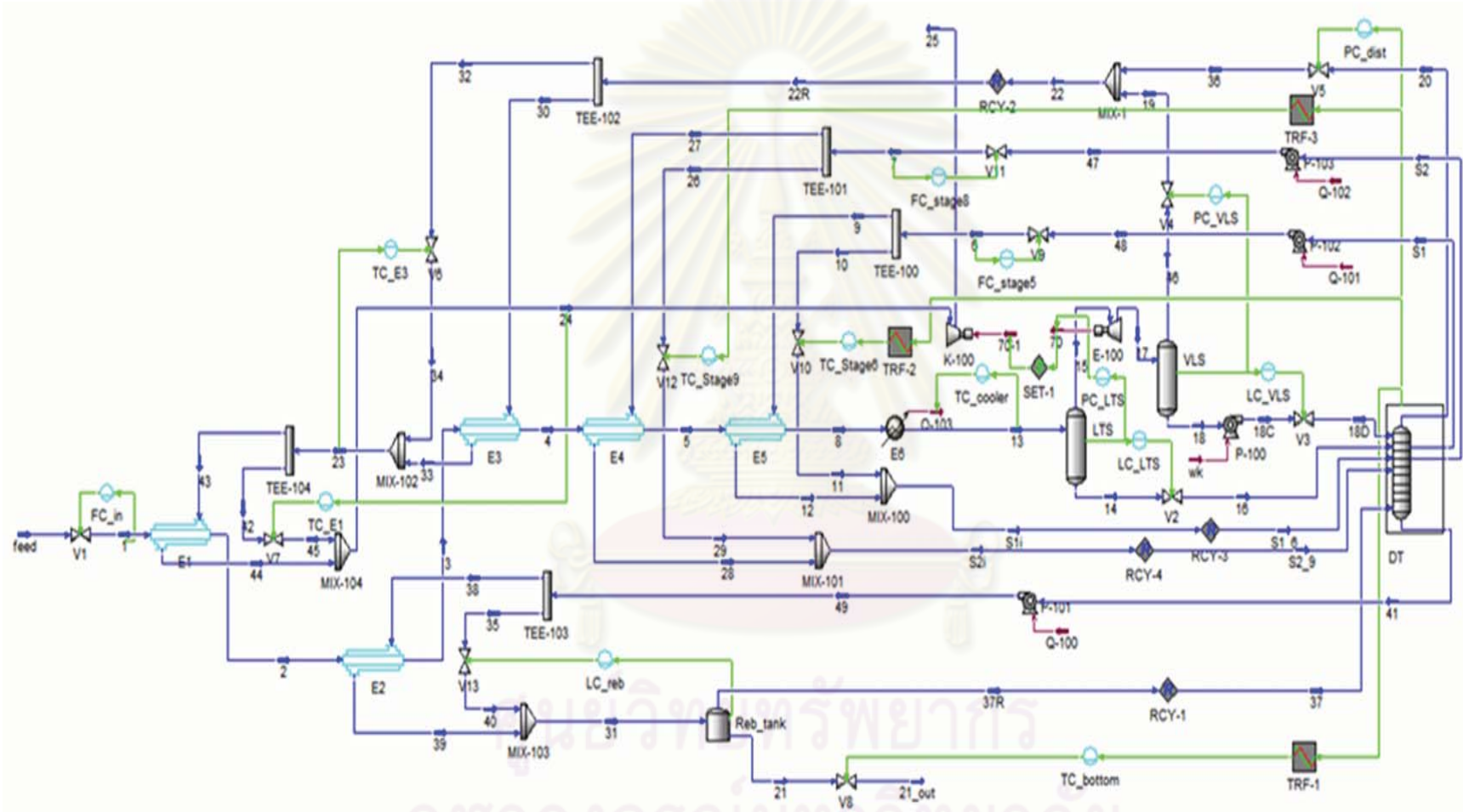

Figure 5.5: Application of the control structure 2 (CS2) to the TEP Alternative 1

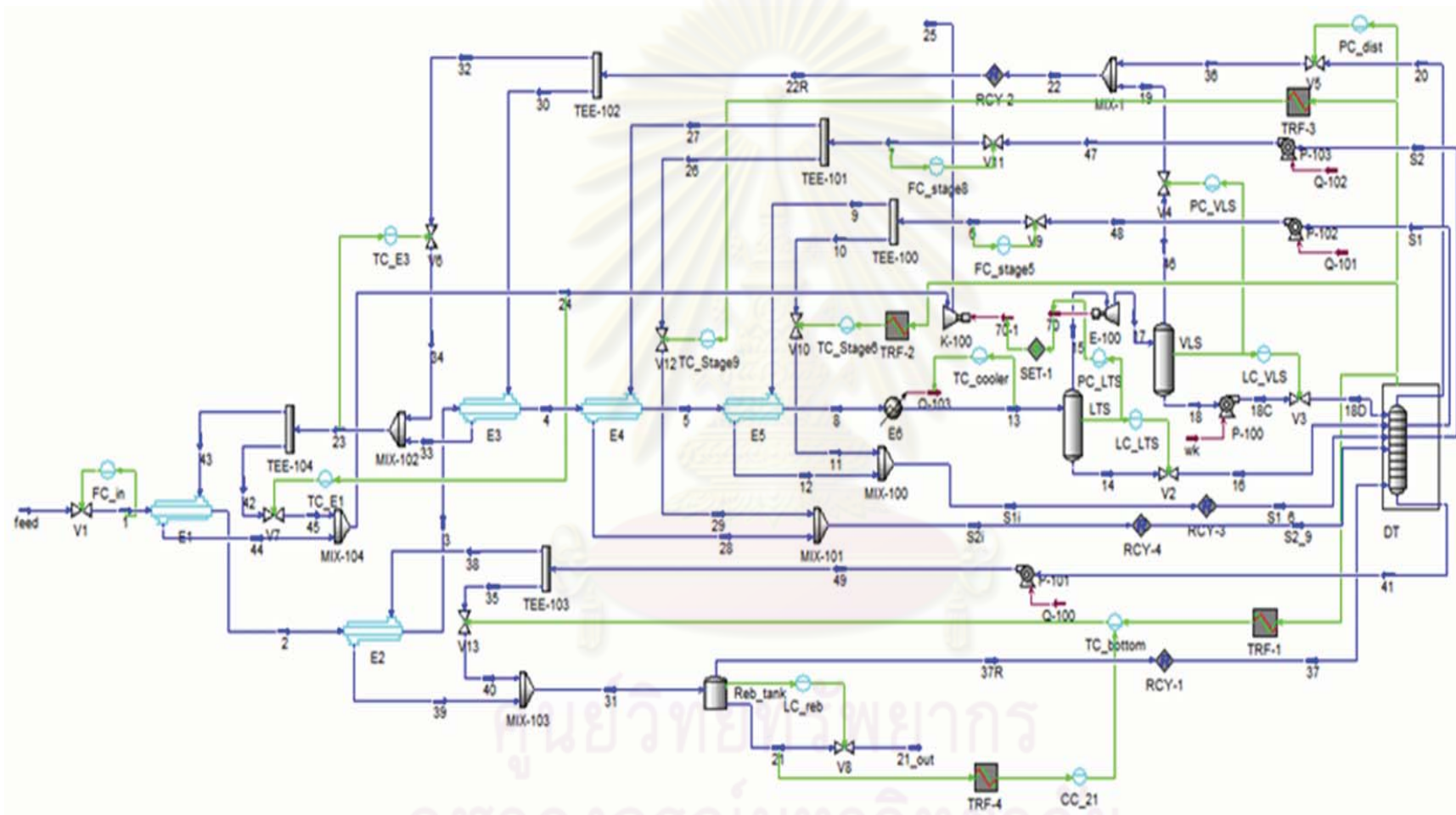

Figure 5.6: Application of the control structure 3 (CS3) to the TEP Alternative 1

Table 5.3: Control Structure and Controller Parameter for the TEP Alternative 2: Control Structure 1 (CS1), Control Structure 2 (CS2) and Control Structure 3 (CS3)

Controller	controlled variable	manipulated variable		Type	Kc	Ti	Td
FC_in	natural gas feed	natural gas feed valve (V1)		PI	0.5	0.3	-
LC_LTS	LTS liquid level	LTS bottom valve (V2)		P	2	-	-
PC_LTS	LTS pressure	expander power (E-100)		PI	2	10	-
LC_VLS	VLS liquid level	VLS bottom valve (V3)		P	2	-	-
PC_VLS	VLS pressure	VLS overhead valve (V4)		PI	2	10	-
TC_E1	E1 cold-outlet temp	E1 bypass cold stream valve (V7)		PID	3.731	0.320	0.071
TC_E3	E3 cold-outlet temp	E3 bypass cold stream valve (V6)		PID	3.624	0.209	0.046
TC_cooler	LTS inlet temperature	heat duty of exchanger E6		PID	4.226	0.315	0.070
PC_dist	DT overhead pressure	DT overhead valve (V5)		PI	2	10	-
LC_reb	DT base level	CS1	DT base valve (V8)	P	2	-	-
		CS2	E2 bypass cold stream valve (V13)	P	1.5	-	-
FC_stage5	Tray-5 side stream flow rate	Tray-5 side stream valve (V9)		PI	0.3497	0.0084	-
TC_stage6	DT tray-6 temperature	E4 bypass cold stream valve (V10)		PID	26.584	1.274	0.283
FC_stage8	Tray-8 side stream flow rate	Tray-8 side stream valve(V11)		PI	0.3784	0.0083	-
TC_stage9	DT tray-9 temperature	E5 bypass cold stream valve (V12)		PID	10.982	1.823	0.405
CC_21	DT bottom methane mole fraction	CS1	E2 bypass cold stream valve (V13)	PID	5.255	4.034	0.896
		CS3	TC_bottom	PID	2.476	4.519	1.004
TC_bottom	DT bottom temperature	CS2	DT base valve (V8)	PID	11.039	1.839	0.409
		CS3	E2 bypass cold stream valve (V13)	PID	10.801	1.778	0.395

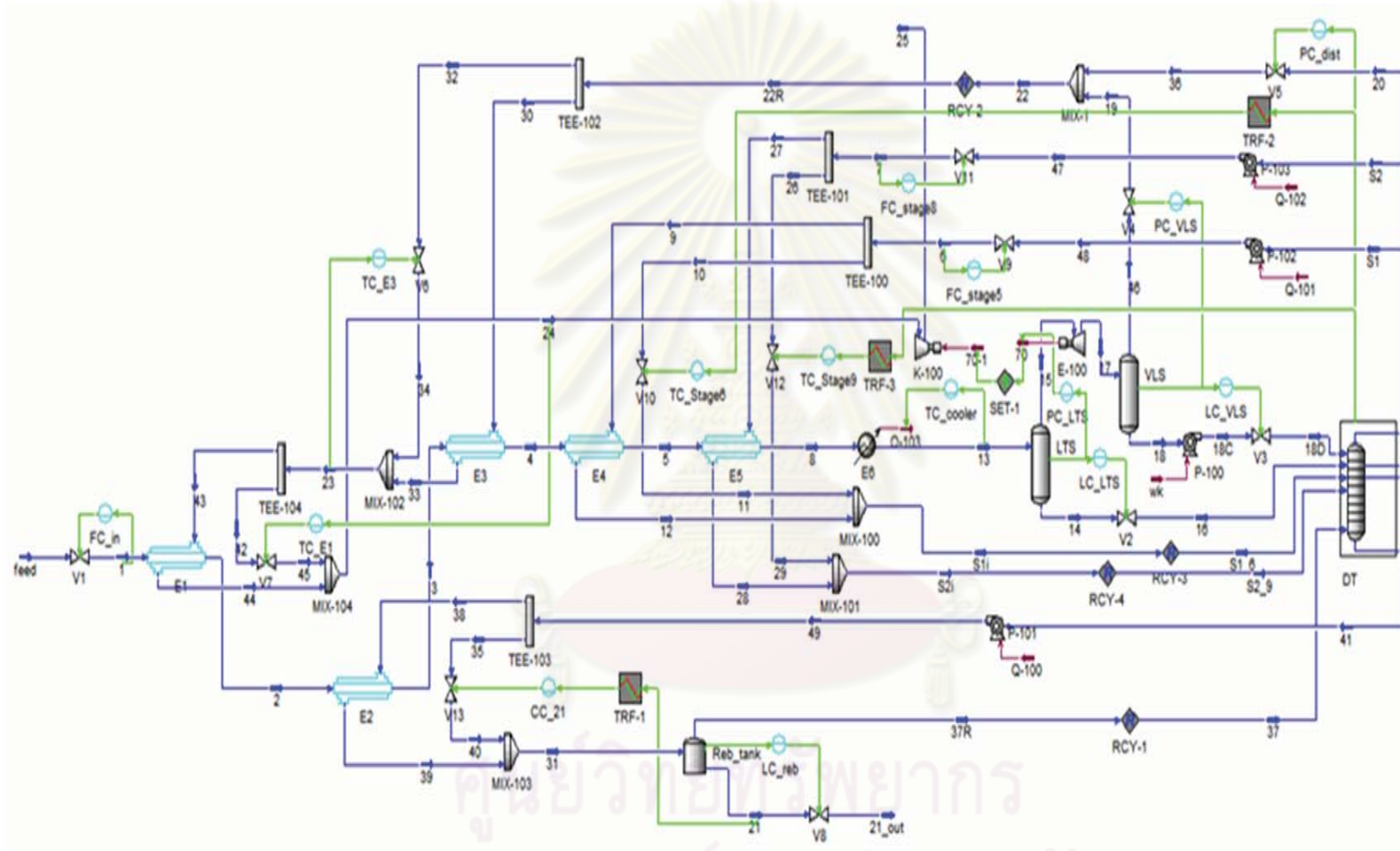

Figure 5.7: Application of the control structure 1 (CS1) to the TEP Alternative 2

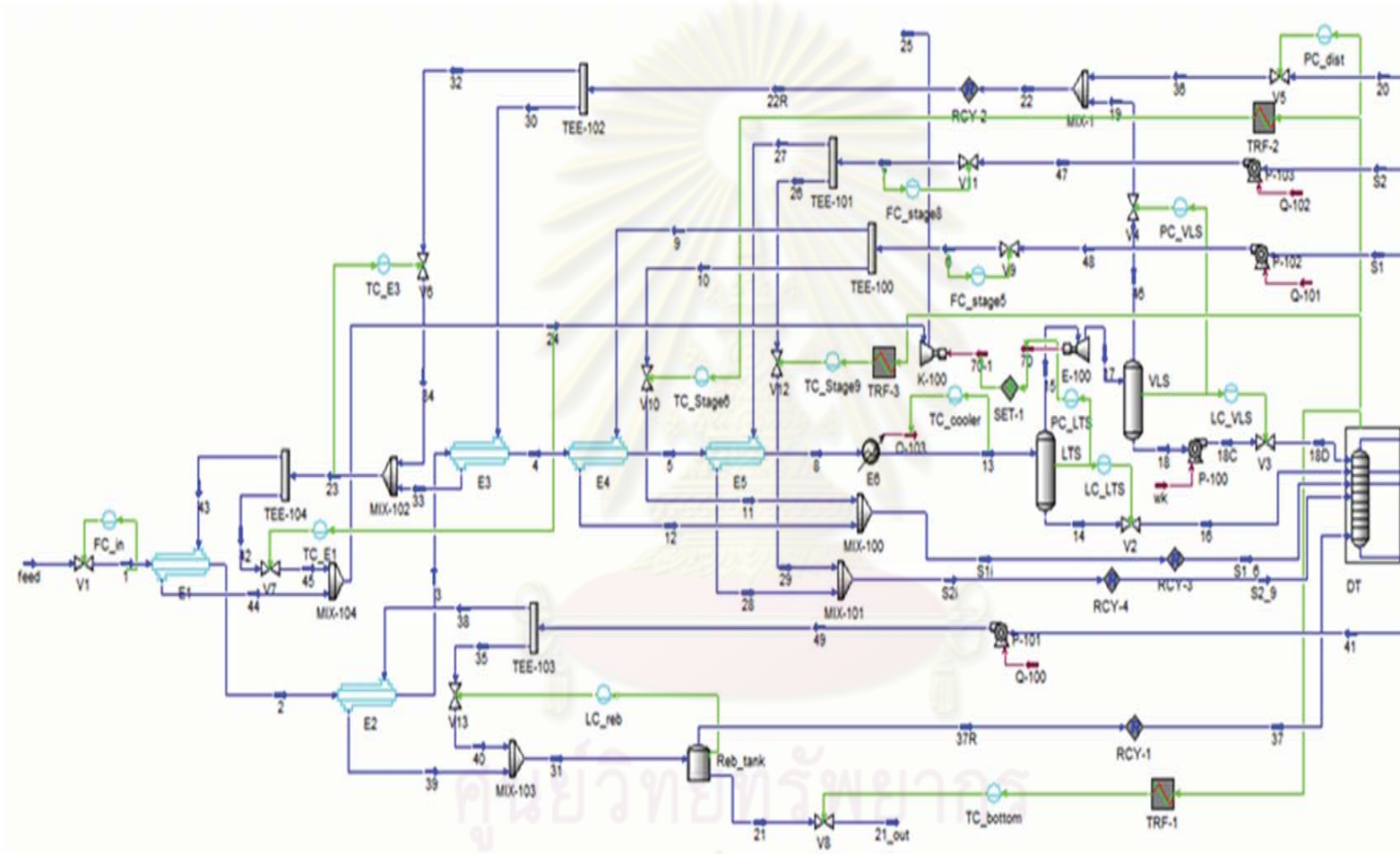

Figure 5.8: Application of the control structure 2 (CS2) to the TEP Alternative 2

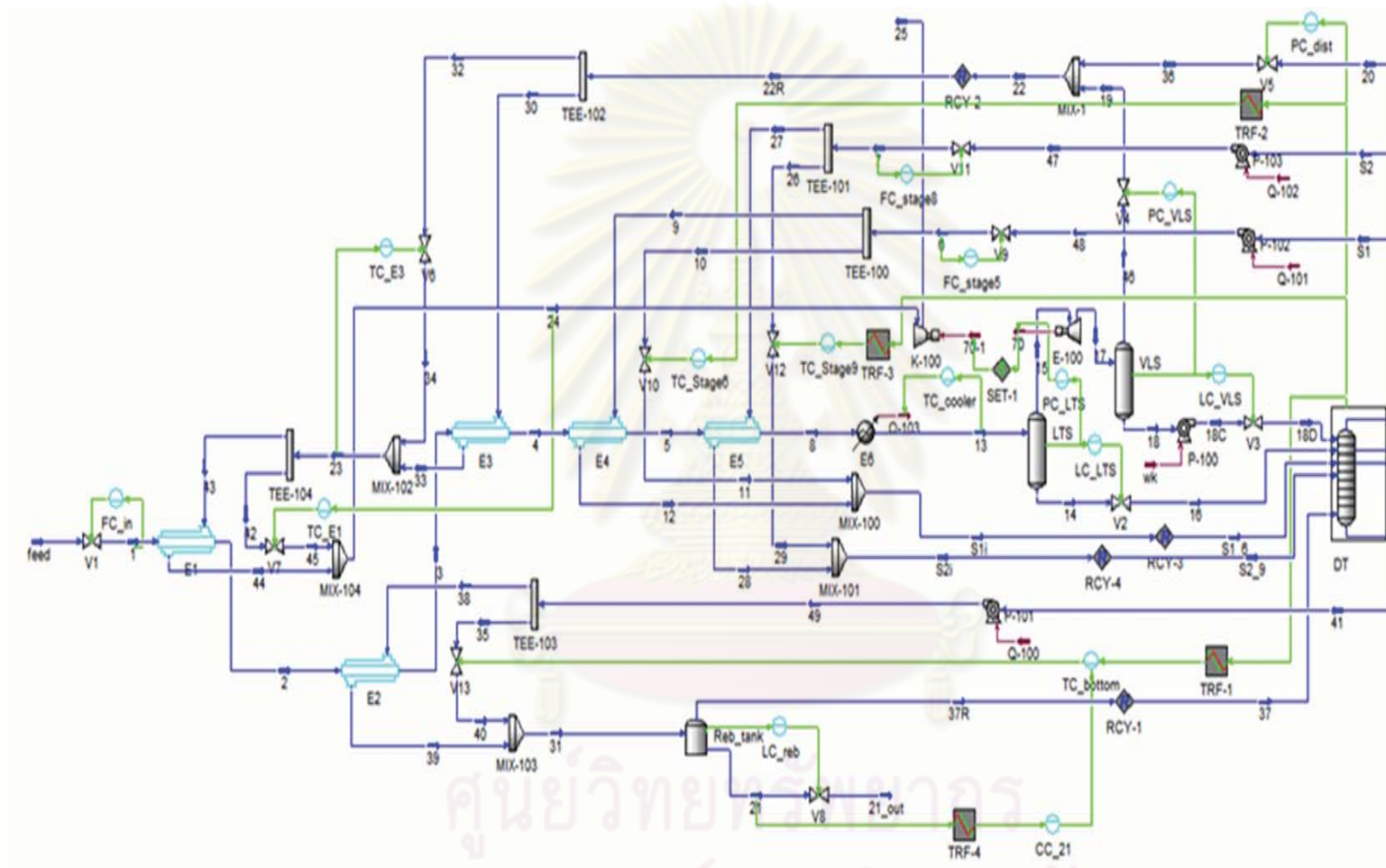

Figure 5.9: Application of the control structure 3 (CS3) to the TEP Alternative 2

Table 5.4: Control Structure and Controller Parameter for the TEP Alternative 3: Control Structure 1 (CS1), Control Structure 2 (CS2) and Control Structure 3 (CS3)

Controller	controlled variable	manipulated variable		Type	Kc	Ti	Td
FC_in	natural gas feed	natural gas feed valve (V1)		PI	0.5	0.3	-
LC_LTS	LTS liquid level	LTS bottom valve (V2)		P	2	-	-
PC_LTS	LTS pressure	expander power (E-100)		PI	2	10	-
LC_VLS	VLS liquid level	VLS bottom valve (V3)		P	2	-	-
PC_VLS	VLS pressure	VLS overhead valve (V4)		PI	2	10	-
TC_E1	E1 cold-outlet temp	E1 bypass cold stream valve (V7)		PID	3.209	0.331	0.074
TC_cooler	LTS inlet temperature	heat duty of exchanger E5		PID	6.734	0.187	0.042
PC_dist	DT overhead pressure	DT overhead valve (V5)		PI	2	10	-
LC_reb	DT base level	CS1	DT base valve (V8)	P	2	-	-
		CS2	E2 bypass hot stream valve (V13)	P	1.5	-	-
FC_stage5	Tray-5 side stream flow rate	Tray-5 side stream valve (V9)		PI	0.3503	0.0084	-
TC_stage6	DT tray-6 temperature	E4 bypass cold stream valve (V10)		PID	25.921	1.447	0.321
FC_stage8	Tray-8 side stream flow rate	Tray-8 side stream valve(V11)		PI	0.3791	0.0083	-
TC_stage9	DT tray-9 temperature	E3 bypass cold stream valve (V12)		PID	12.677	1.774	0.394
CC_21	DT bottom methane mole fraction	CS1	E2 bypass hot stream valve (V13)	PID	7.808	3.733	0.830
		CS3	TC_bottom	PID	3.787	4.423	0.983
TC_bottom	DT bottom temperature	CS2	DT base valve (V8)	PID	11.707	1.747	0.388
		CS3	E2 bypass hot stream valve (V13)	PID	12.026	2.219	0.493

จุฬาลงกรณ์มหาวิทยาลัย

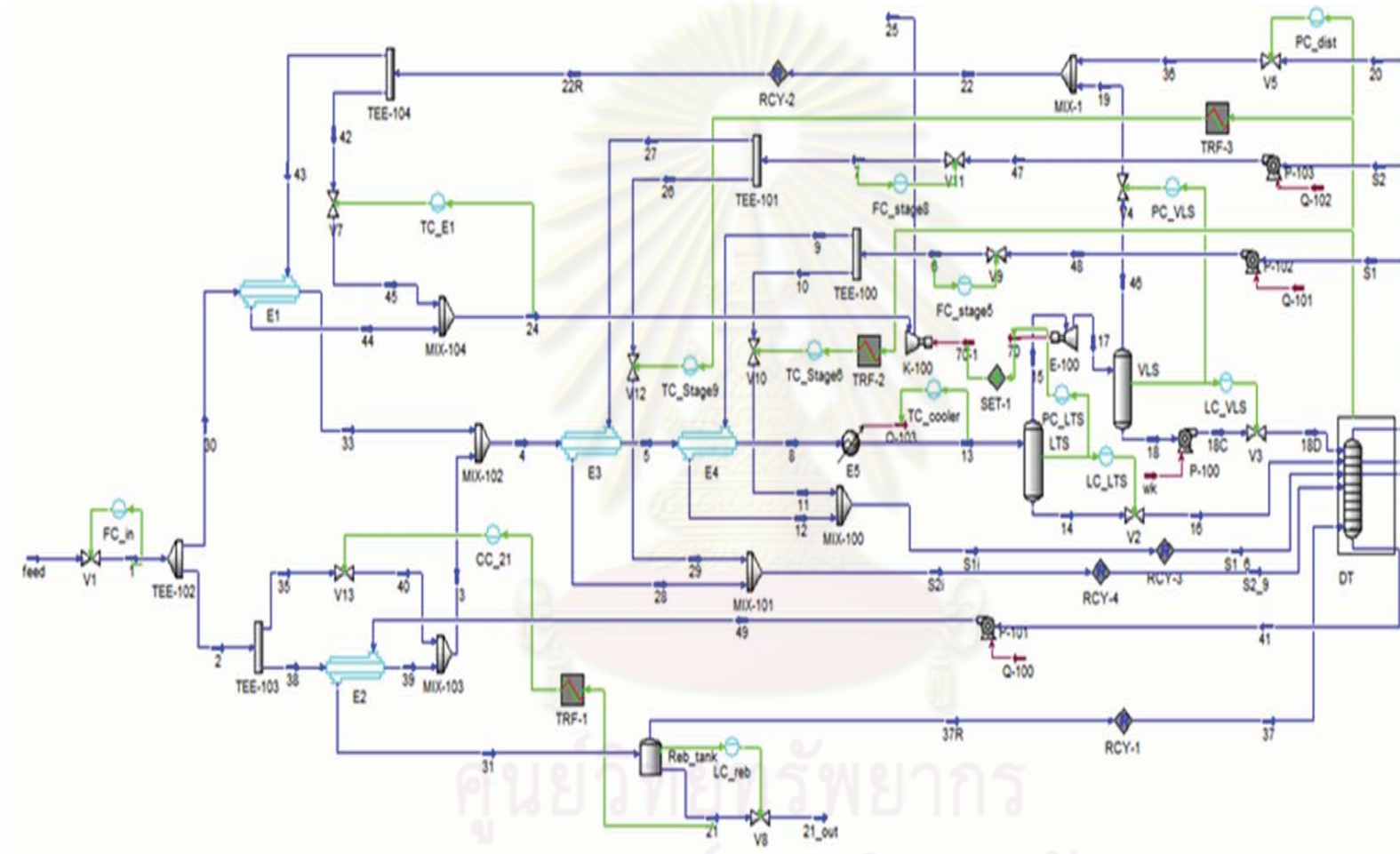

Figure 5.10: Application of the control structure 1 (CS1) to the TEP Alternative 3

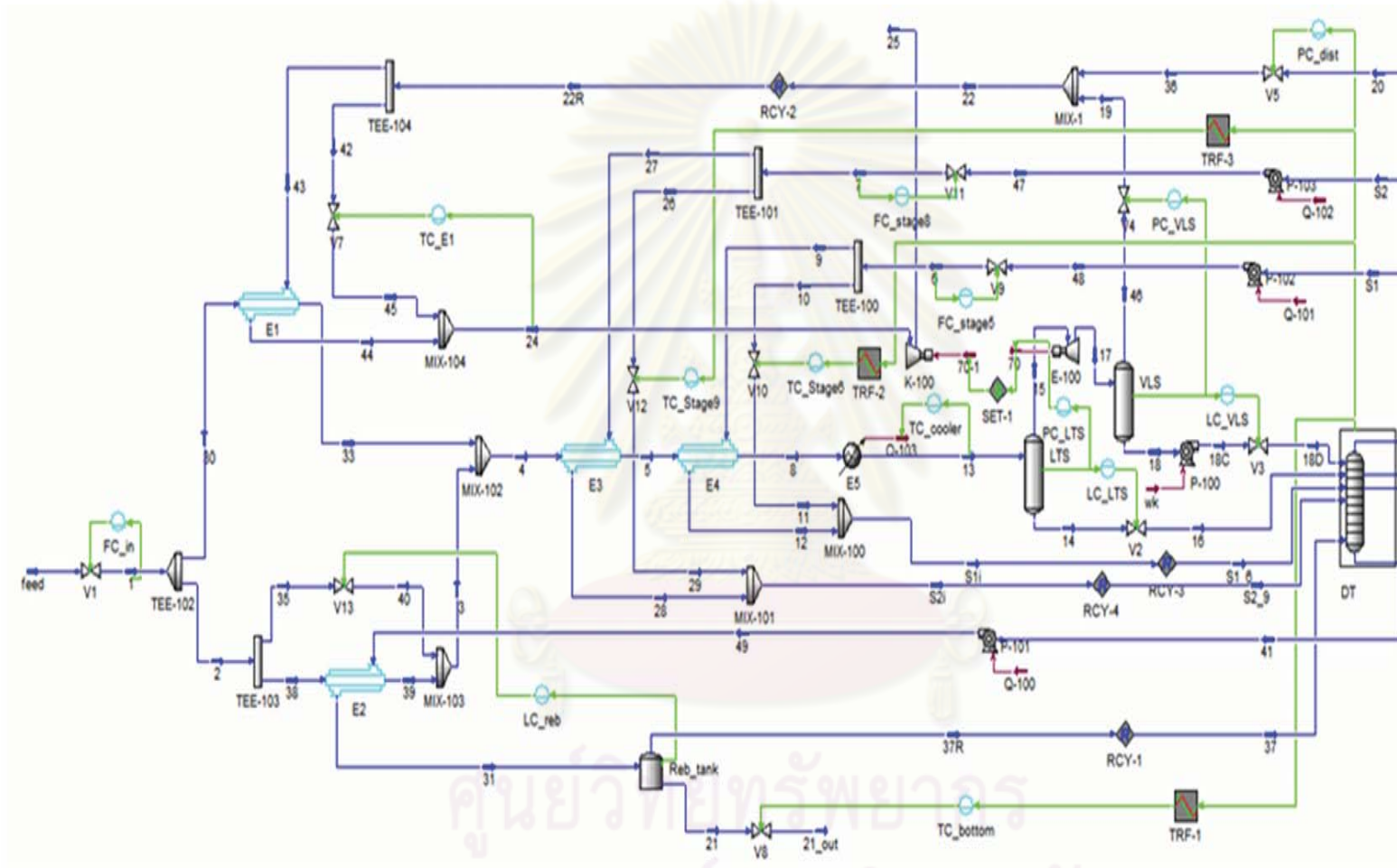

Figure 5.11: Application of the control structure 2 (CS2) to the TEP Alternative 3

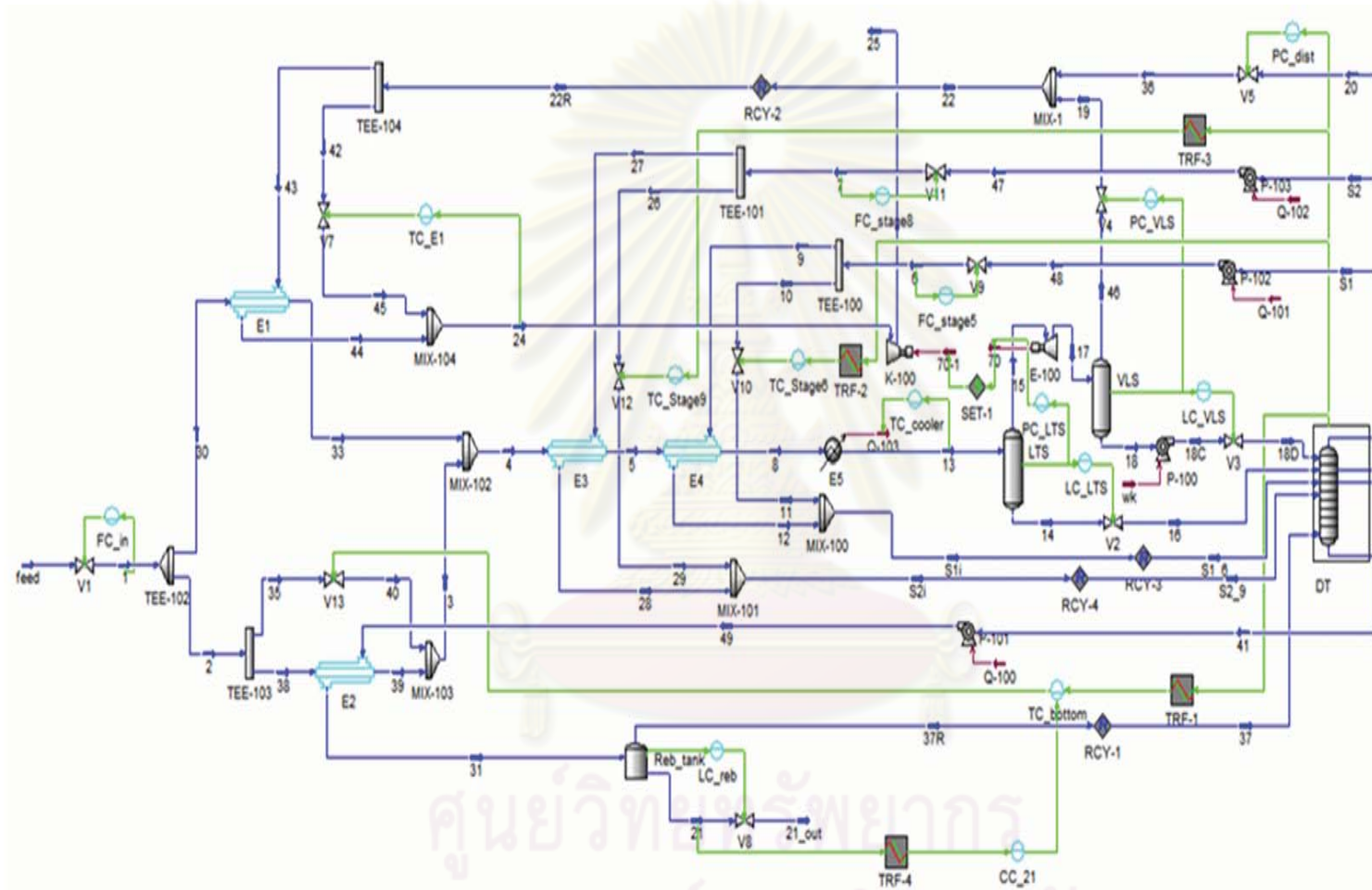

Figure 5.12: Application of the control structure 3 (CS3) to the TEP Alternative 3

Table 5.5: Control Structure and Controller Parameter for the TEP Alternative 4: Control Structure 1 (CS1), Control Structure 2 (CS2) and Control Structure 3 (CS3)

Controller	controlled variable	manipulated variable		Type	Kc	Ti	Td
FC_in	natural gas feed	natural gas feed valve (V1)		PI	0.5	0.3	-
LC_LTS	LTS liquid level	LTS bottom valve (V2)		P	2	-	-
PC_LTS	LTS pressure	expander power (E-100)		PI	2	10	-
LC_VLS	VLS liquid level	VLS bottom valve (V3)		P	2	-	-
PC_VLS	VLS pressure	VLS overhead valve (V4)		PI	2	10	-
TC_E1	E1 cold-outlet temp	E1 bypass cold stream valve (V7)		PID	3.359	0.328	0.073
TC_cooler	LTS inlet temperature	heat duty of exchanger E5		PID	6.734	0.187	0.042
PC_dist	DT overhead pressure	DT overhead valve (V5)		PI	2	10	-
LC_reb	DT base level	CS1	DT base valve (V8)	P	2	-	-
		CS2	E2 bypass hot stream valve (V13)	P	1.5	-	-
FC_stage5	Tray-5 side stream flow rate	Tray-5 side stream valve (V9)		PI	0.3497	0.0084	-
TC_stage6	DT tray-6 temperature	E4 bypass cold stream valve (V10)		PID	27.241	1.249	0.278
FC_stage8	Tray-8 side stream flow rate	Tray-8 side stream valve(V11)		PI	0.3784	0.0083	-
TC_stage9	DT tray-9 temperature	E3 bypass cold stream valve (V12)		PID	12.711	1.622	0.360
CC_21	DT bottom methane mole fraction	CS1	E2 bypass hot stream valve (V13)	PID	6.927	3.786	0.841
		CS3	TC_bottom	PID	3.019	4.605	1.023
TC_bottom	DT bottom temperature	CS2	DT base valve (V8)	PID	11.316	1.769	0.393
		CS3	E2 bypass hot stream valve (V13)	PID	10.451	2.159	0.480

จุฬาลงกรณ์มหาวิทยาลัย

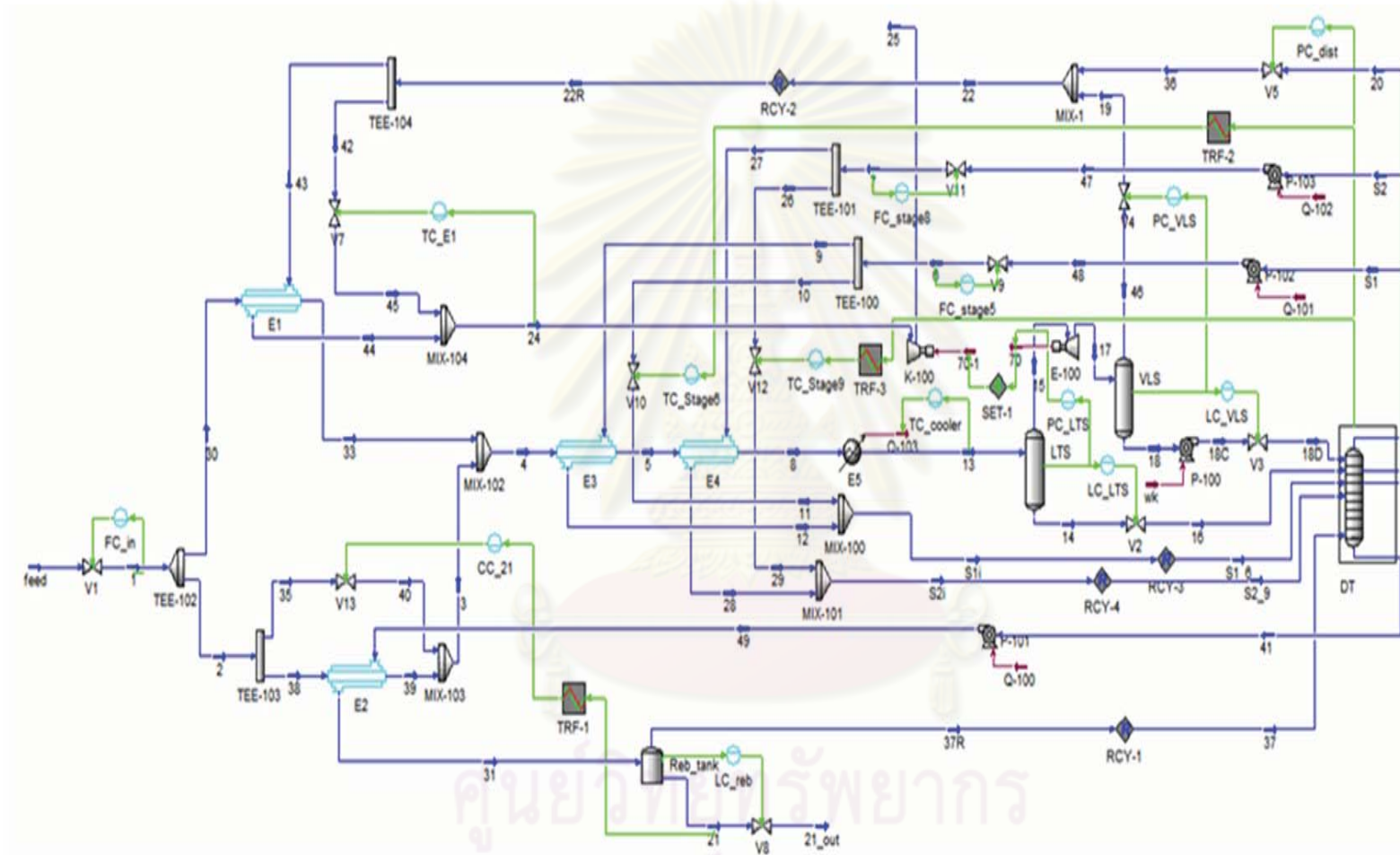

Figure 5.13: Application of the control structure 1 (CS1) to the TEP Alternative 4

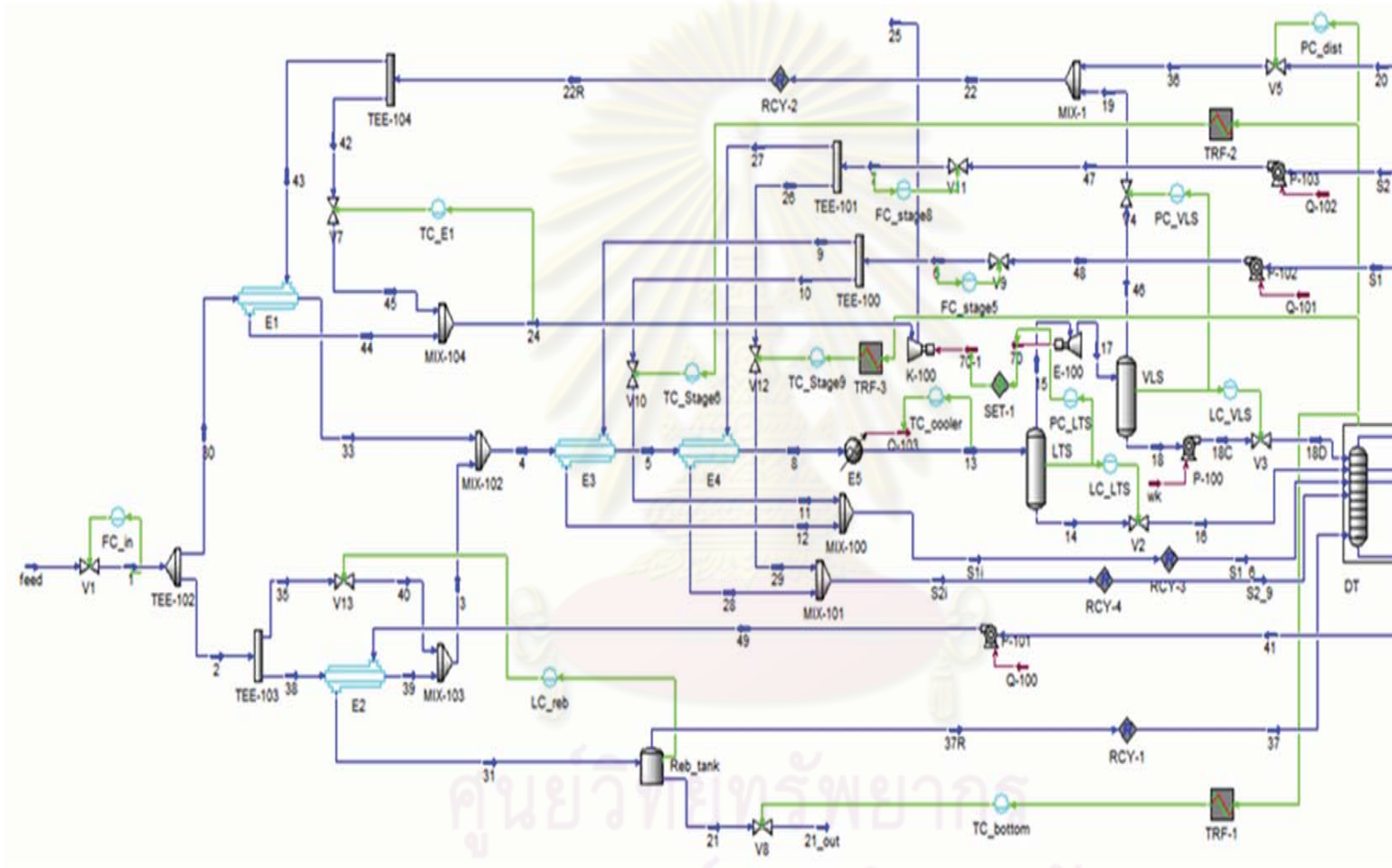

Figure 5.14: Application of the control structure 2 (CS2) to the TEP Alternative 4

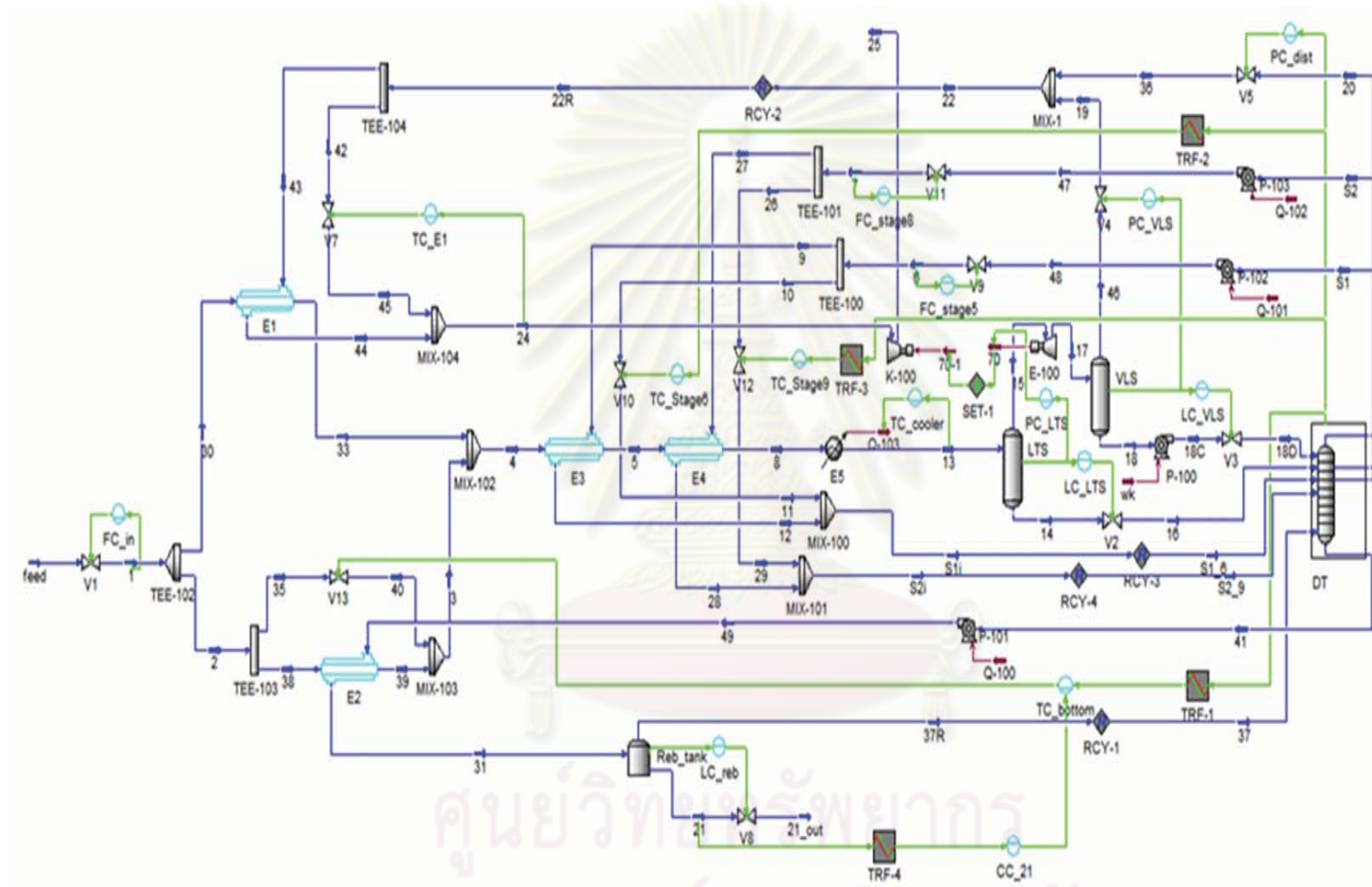

Figure 5.15: Application of the control structure 3 (CS3) to the TEP Alternative 4

Table 5.6: Control Structure and Controller Parameter for the TEP Alternative 5: Control Structure 1 (CS1), Control Structure 2 (CS2) and Control Structure 3 (CS3)

Controller	controlled variable	manipulated variable		Type	Kc	Ti	Td
FC_in	natural gas feed	natural gas feed valve (V1)		PI	0.5	0.3	-
LC_LTS	LTS liquid level	LTS bottom valve (V2)		P	2	-	-
PC_LTS	LTS pressure	expander power (E-100)		PI	2	10	-
LC_VLS	VLS liquid level	VLS bottom valve (V3)		P	2	-	-
PC_VLS	VLS pressure	VLS overhead valve (V4)		PI	2	10	-
TC_E1	E1 cold-outlet temp	E1 bypass cold stream valve (V7)		PID	3.769	0.319	0.071
TC_E4	E4 cold-outlet temp	E4 bypass cold stream valve (V6)		PID	3.666	0.217	0.048
TC_cooler	LTS inlet temperature	heat duty of exchanger E6		PID	4.127	0.312	0.069
PC_dist	DT overhead pressure	DT overhead valve (V5)		PI	2	10	-
LC_reb	DT base level	CS1	DT base valve (V8)	P	2	-	-
		CS2	E2 bypass cold stream valve (V13)	P	1.5	-	-
FC_stage5	Tray-5 side stream flow rate	Tray-5 side stream valve (V9)		PI	0.3503	0.0084	-
TC_stage6	DT tray-6 temperature	E5 bypass cold stream valve (V10)		PID	26.665	1.300	0.289
FC_stage8	Tray-8 side stream flow rate	Tray-8 side stream valve(V11)		PI	0.3827	0.0083	-
TC_stage9	DT tray-9 temperature	E3 bypass cold stream valve (V12)		PID	21.901	1.277	0.284
CC_21	DT bottom methane mole fraction	CS1	E2 bypass cold stream valve (V13)	PID	5.330	3.995	0.888
		CS3	TC_bottom	PID	2.421	4.564	1.014
TC_bottom	DT bottom temperature	CS2	DT base valve (V8)	PID	10.145	1.972	0.438
		CS3	E2 bypass cold stream valve (V13)	PID	10.469	1.819	0.404

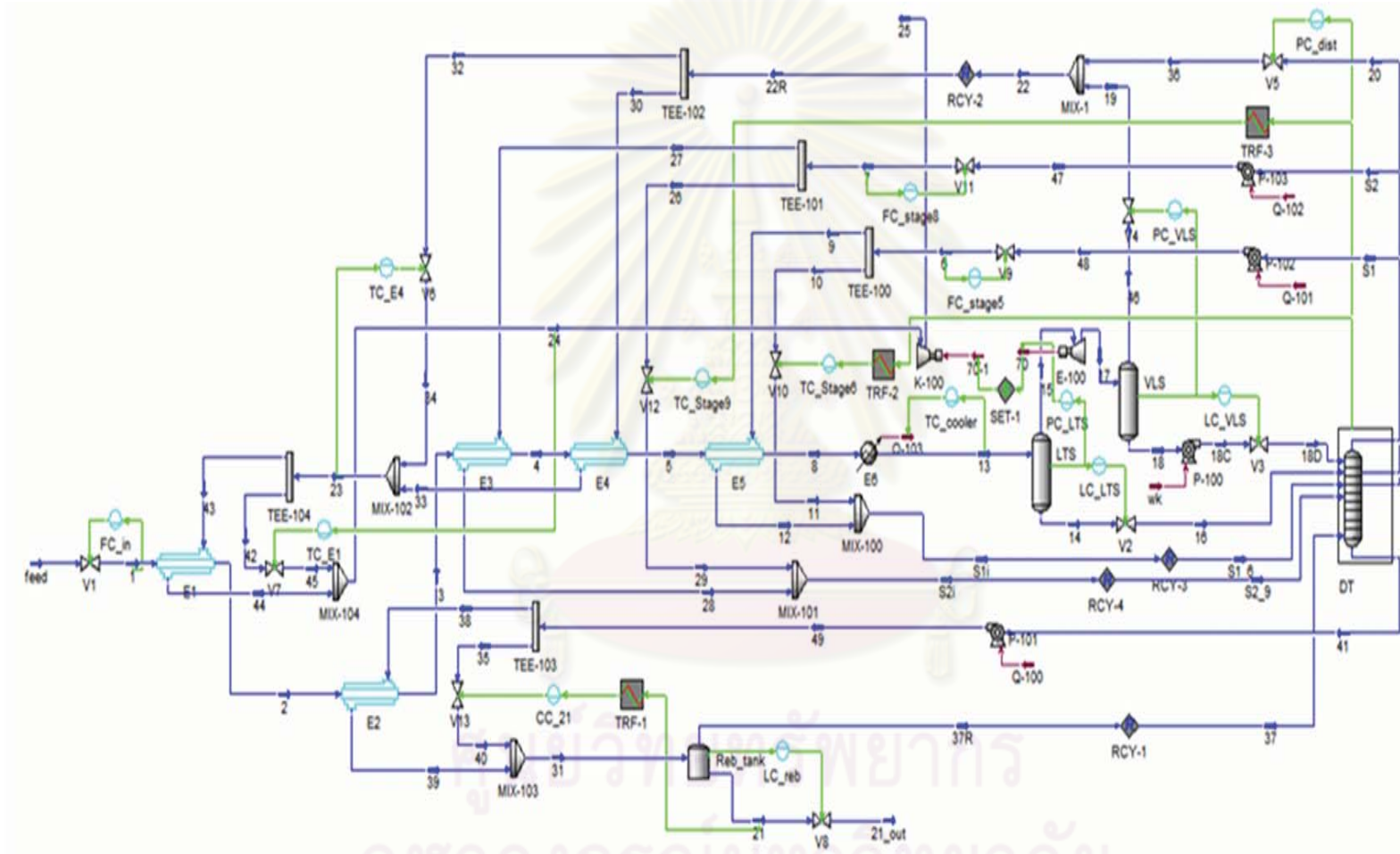

Figure 5.16: Application of the control structure 1 (CS1) to the TEP Alternative 5

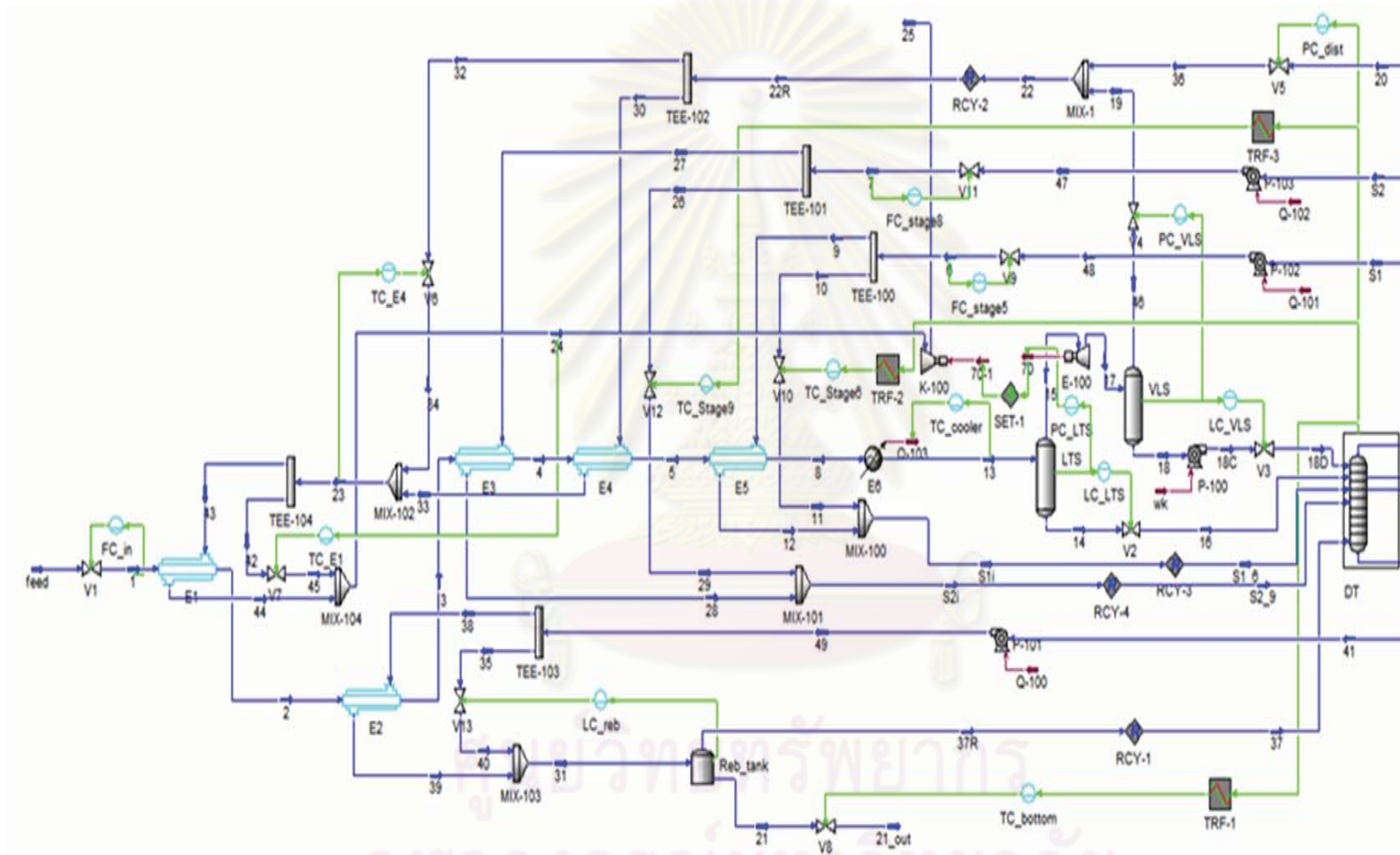

Figure 5.17: Application of the control structure 2 (CS2) to the TEP Alternative 5

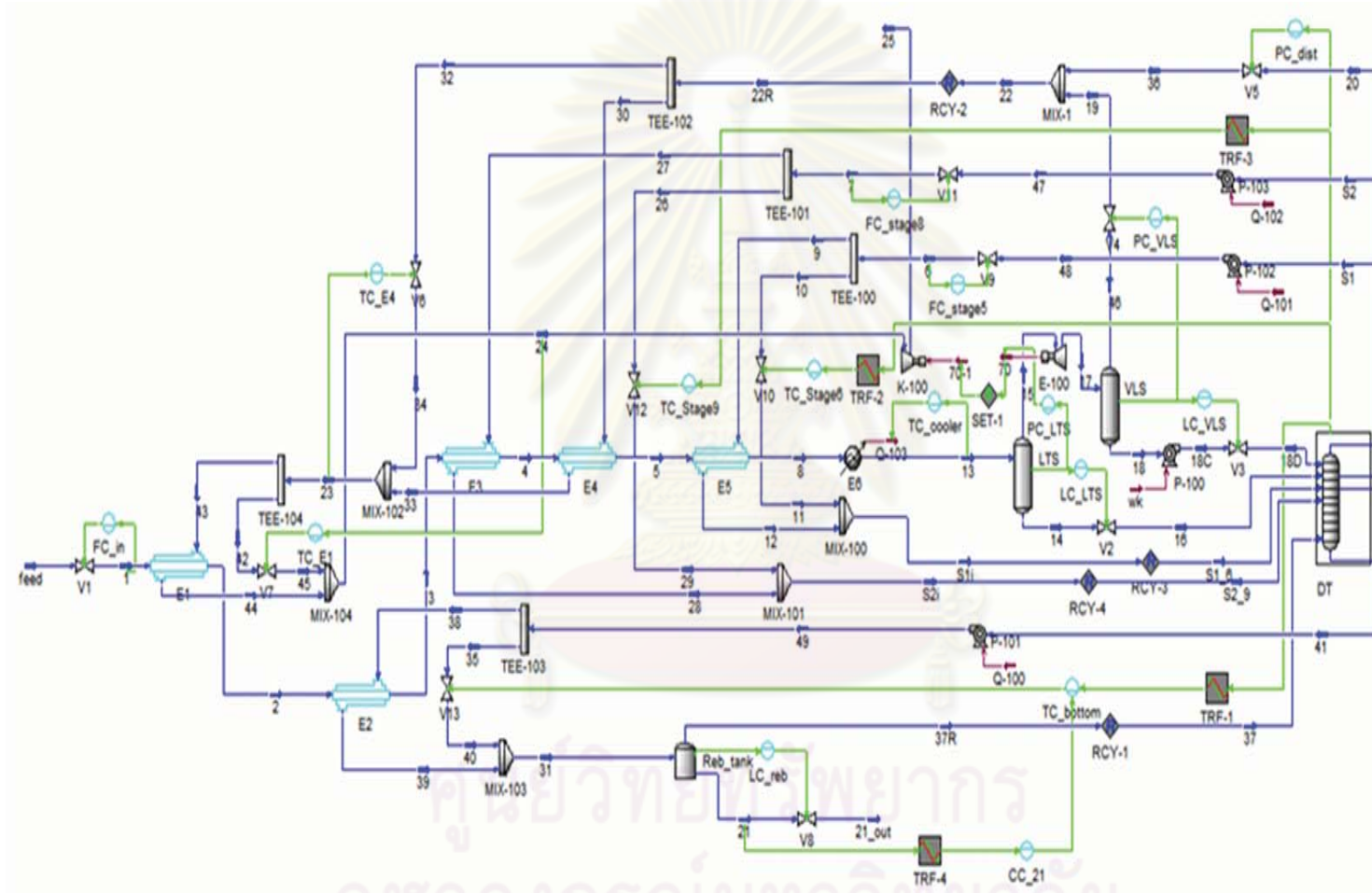

Figure 5.18: Application of the control structure 3 (CS3) to the TEP Alternative 5

Table 5.7: Control Structure and Controller Parameter for the TEP Alternative 6: Control Structure 1 (CS1), Control Structure 2 (CS2) and Control Structure 3 (CS3)

Controller	controlled variable	manipulated variable		Type	Kc	Ti	Td
FC_in	natural gas feed	natural gas feed valve (V1)		PI	0.5	0.3	-
LC_LTS	LTS liquid level	LTS bottom valve (V2)		P	2	-	-
PC_LTS	LTS pressure	expander power (E-100)		PI	2	10	-
LC_VLS	VLS liquid level	VLS bottom valve (V3)		P	2	-	-
PC_VLS	VLS pressure	VLS overhead valve (V4)		PI	2	10	-
TC_E1	E1 cold-outlet temp	E1 bypass cold stream valve (V7)		PID	3.817	0.318	0.071
TC_E5	E5 cold-outlet temp	E5 bypass cold stream valve (V6)		PID	5.694	0.285	0.063
TC_cooler	LTS inlet temperature	heat duty of exchanger E6		PID	3.625	0.327	0.073
PC_dist	DT overhead pressure	DT overhead valve (V5)		PI	2	10	-
LC_reb	DT base level	CS1	DT base valve (V8)	P	2	-	-
		CS2	E2 bypass cold stream valve (V13)	P	1.5	-	-
FC_stage5	Tray-5 side stream flow rate	Tray-5 side stream valve (V9)		PI	0.3481	0.0084	-
TC_stage6	DT tray-6 temperature	E4 bypass cold stream valve (V10)		PID	29.013	1.343	0.299
FC_stage8	Tray-8 side stream flow rate	Tray-8 side stream valve(V11)		PI	0.3823	0.0083	-
TC_stage9	DT tray-9 temperature	E3 bypass cold stream valve (V12)		PID	19.490	1.661	0.369
CC_21	DT bottom methane mole fraction	CS1	E2 bypass cold stream valve (V13)	PID	5.305	4.001	0.889
		CS3	TC_bottom	PID	2.462	4.524	1.005
TC_bottom	DT bottom temperature	CS2	DT base valve (V8)	PID	10.005	1.989	0.442
		CS3	E2 bypass cold stream valve (V13)	PID	10.836	1.792	0.398

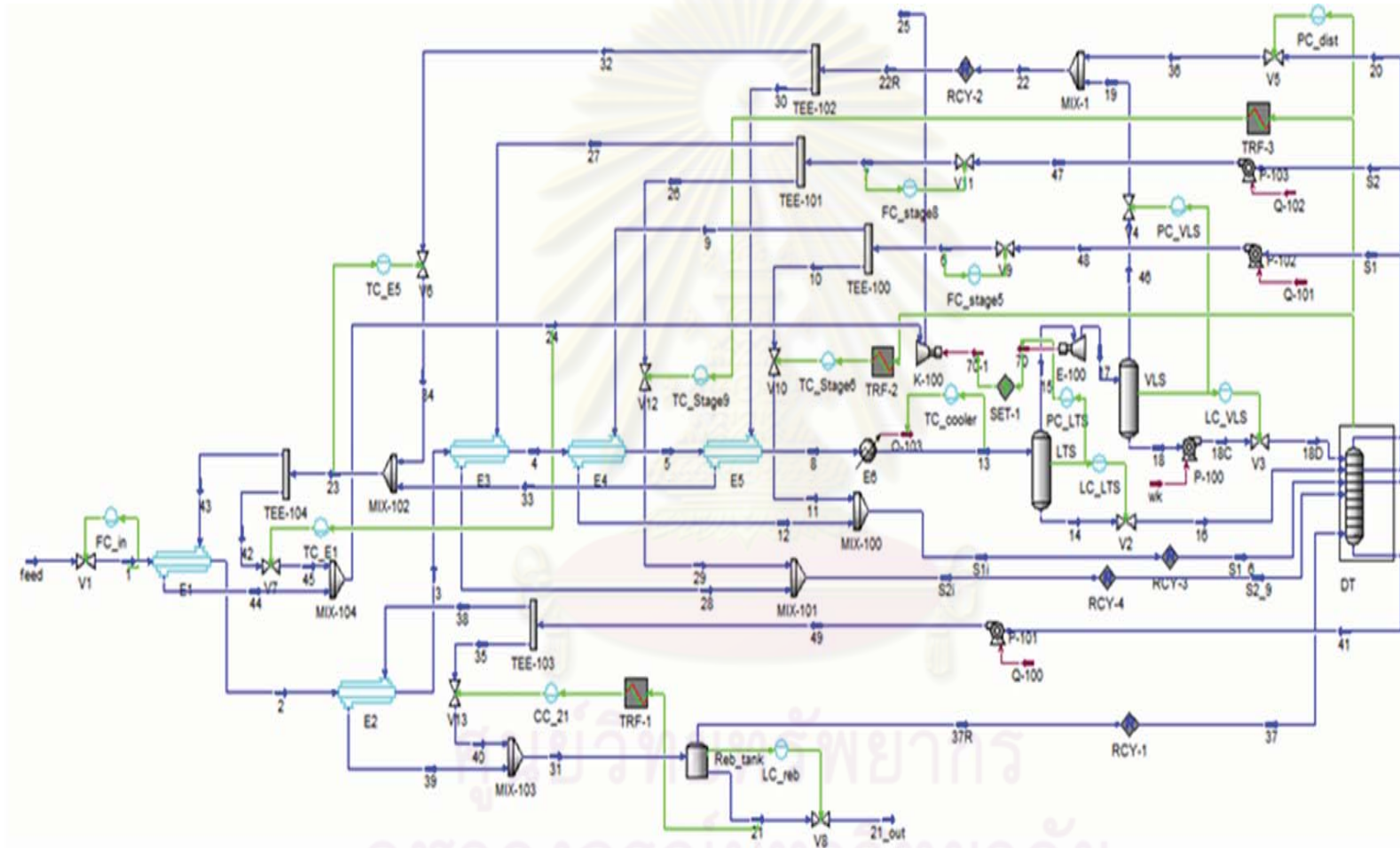

Figure 5.19: Application of the control structure 1 (CS1) to the TEP Alternative 6

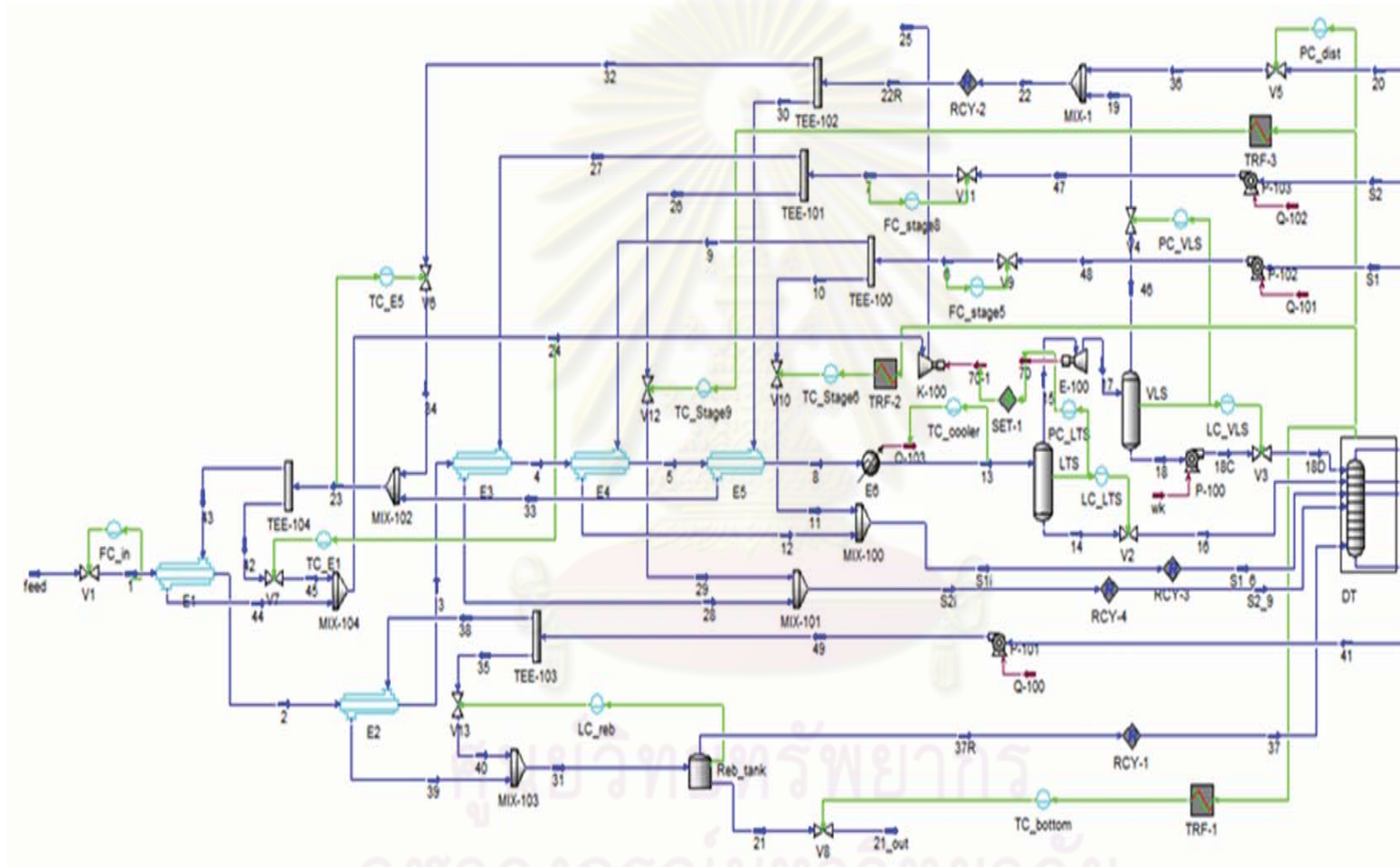

Figure 5.20: Application of the control structure 2 (CS2) to the TEP Alternative 6

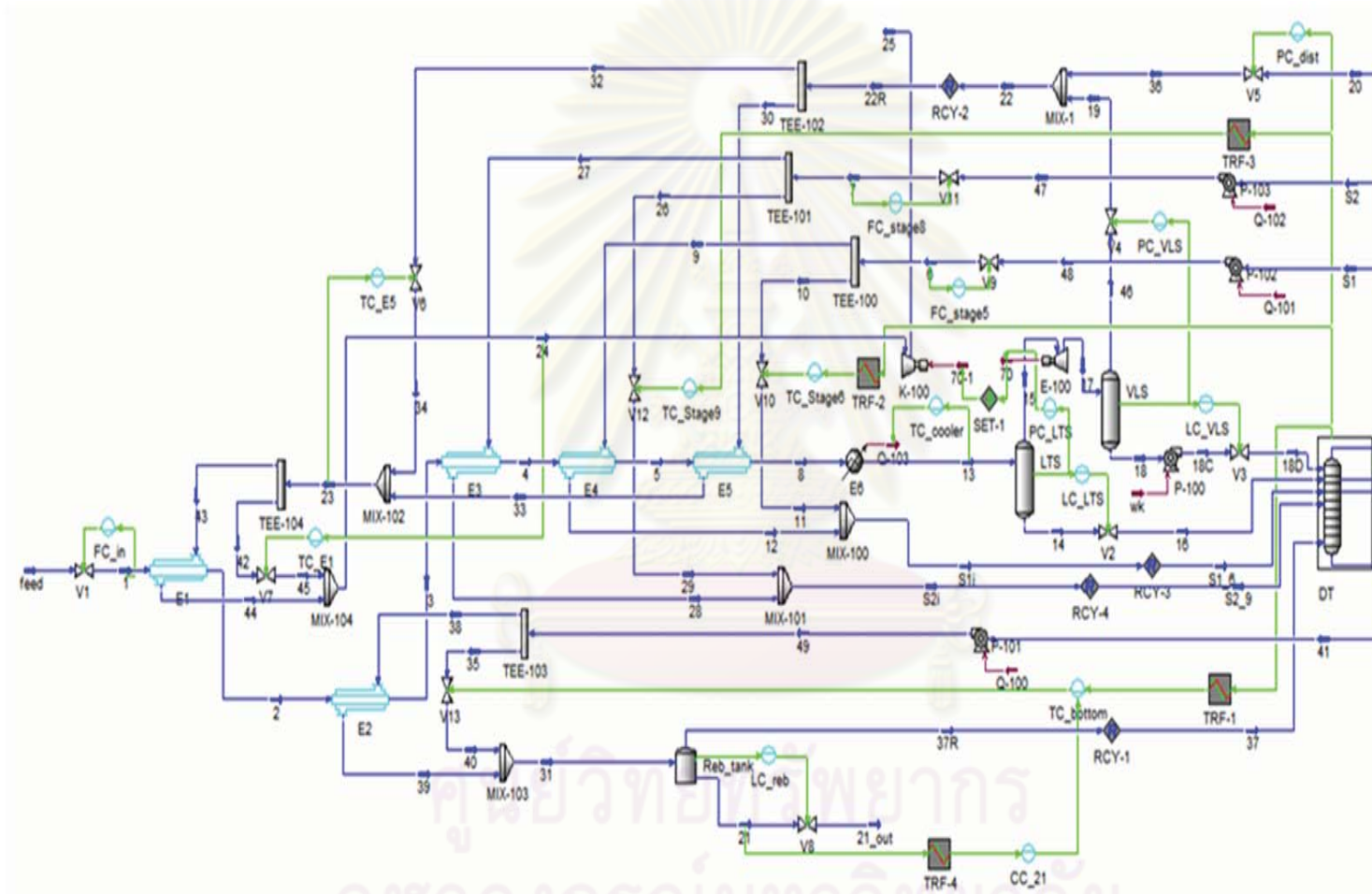

Figure 5.21: Application of the control structure 3 (CS3) to the TEP Alternative 6

Table 5.8: Control Structure and Controller Parameter for the TEP Alternative 7: Control Structure 1 (CS1), Control Structure 2 (CS2) and Control Structure 3 (CS3)

Controller	controlled variable	manipulated variable		Type	Kc	Ti	Td
FC_in	natural gas feed	natural gas feed valve (V1)		PI	0.5	0.3	-
LC_LTS	LTS liquid level	LTS bottom valve (V2)		P	2	-	-
PC_LTS	LTS pressure	expander power (E-100)		PI	2	10	-
LC_VLS	VLS liquid level	VLS bottom valve (V3)		P	2	-	-
PC_VLS	VLS pressure	VLS overhead valve (V4)		PI	2	10	-
TC_E1	E1 cold-outlet temp	E1 bypass cold stream valve (V7)		PID	3.772	0.319	0.071
TC_E4	E4 cold-outlet temp	E4 bypass cold stream valve (V6)		PID	4.008	0.261	0.058
TC_cooler	LTS inlet temperature	heat duty of exchanger E6		PID	4.213	0.310	0.069
PC_dist	DT overhead pressure	DT overhead valve (V5)		PI	2	10	-
LC_reb	DT base level	CS1	DT base valve (V8)	P	2	-	-
		CS2	E2 bypass cold stream valve (V13)	P	1.5	-	-
FC_stage5	Tray-5 side stream flow rate	Tray-5 side stream valve (V9)		PI	0.3471	0.0084	-
TC_stage6	DT tray-6 temperature	E3 bypass cold stream valve (V10)		PID	29.278	1.210	0.269
FC_stage8	Tray-8 side stream flow rate	Tray-8 side stream valve(V11)		PI	0.3785	0.0083	-
TC_stage9	DT tray-9 temperature	E5 bypass cold stream valve (V12)		PID	11.315	1.840	0.409
CC_21	DT bottom methane mole fraction	CS1	E2 bypass cold stream valve (V13)	PID	5.336	3.986	0.886
		CS3	TC_bottom	PID	2.433	4.542	1.009
TC_bottom	DT bottom temperature	CS2	DT base valve (V8)	PID	11.042	1.844	0.410
		CS3	E2 bypass cold stream valve (V13)	PID	11.094	1.729	0.384

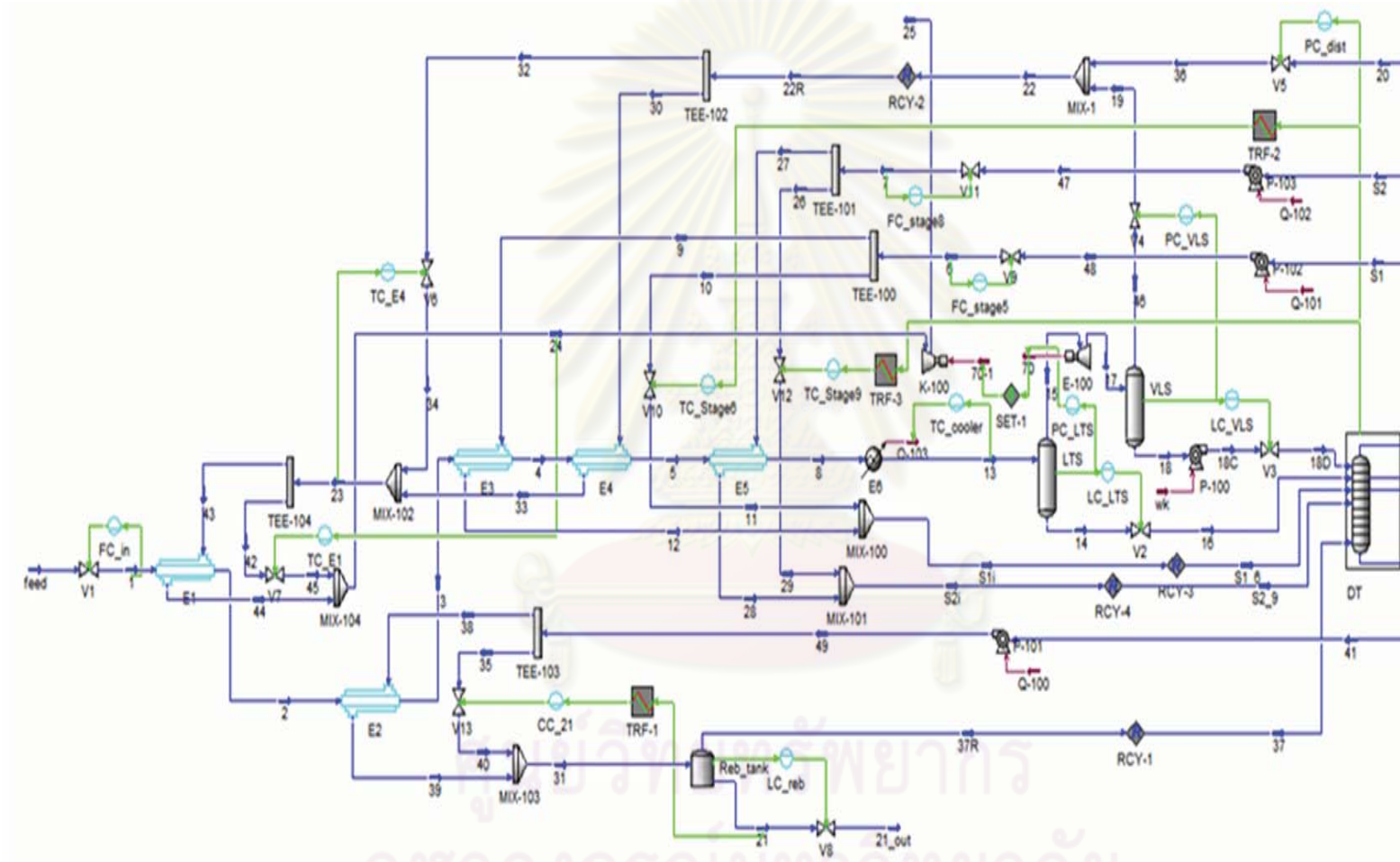

Figure 5.22: Application of the control structure 1 (CS1) to the TEP Alternative 7

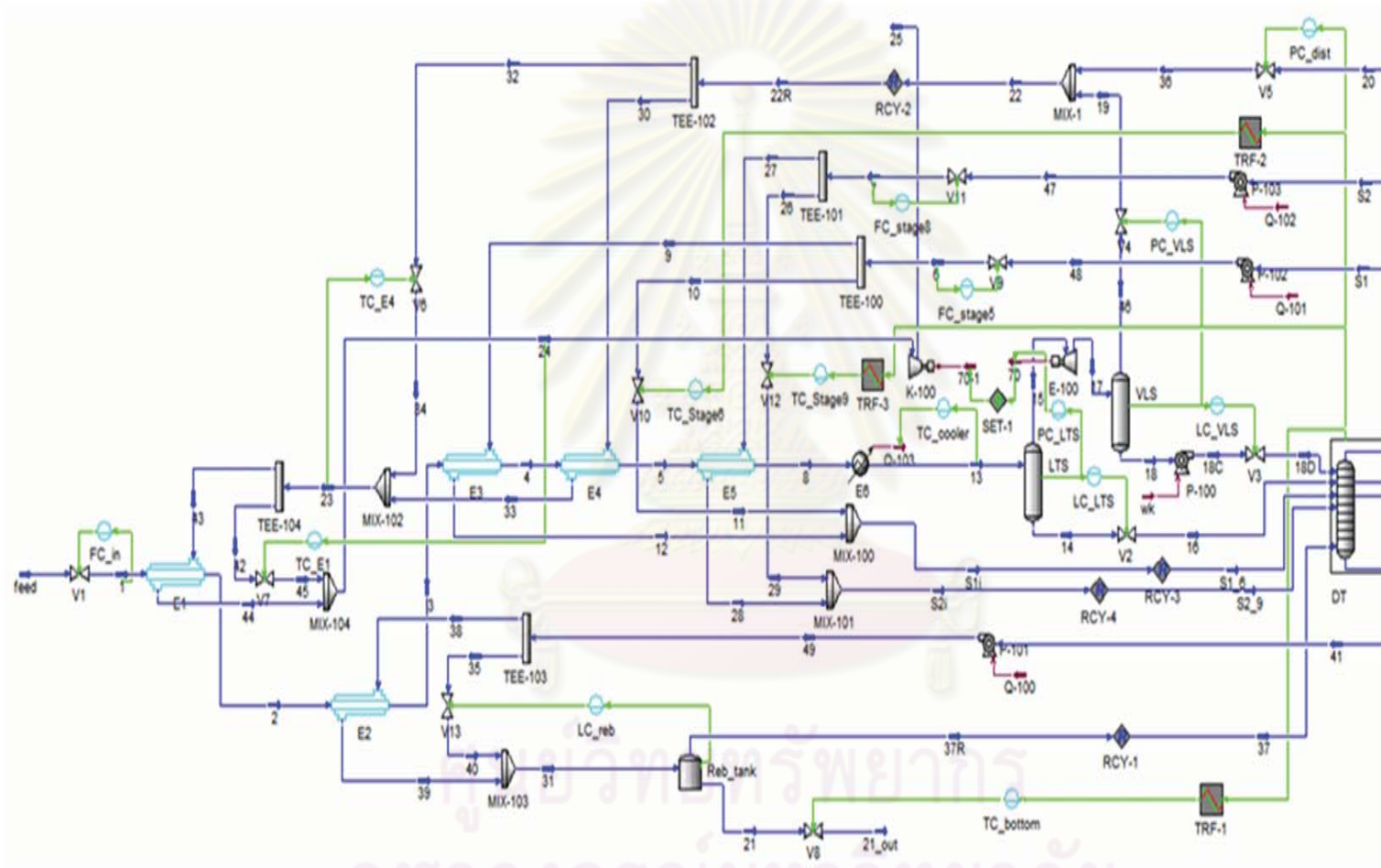

Figure 5.23: Application of the control structure 2 (CS2) to the TEP Alternative 7

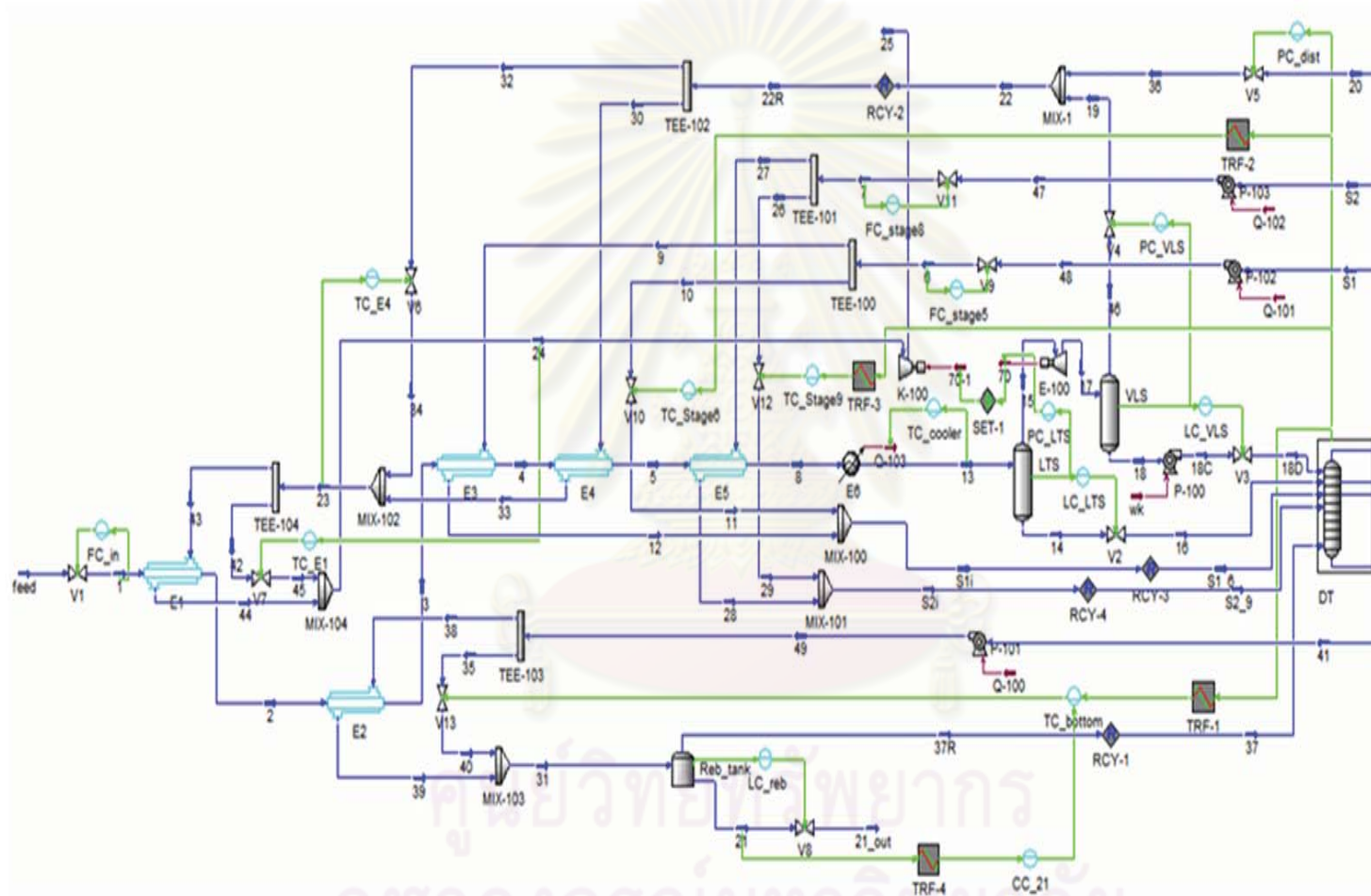

Figure 5.24: Application of the control structure 3 (CS3) to the TEP Alternative 7

Table 5.9: Control Structure and Controller Parameter for the TEP Alternative 8: Control Structure 1 (CS1), Control Structure 2 (CS2) and Control Structure 3 (CS3)

Controller	controlled variable	manipulated variable		Type	Kc	Ti	Td
FC_in	natural gas feed	natural gas feed valve (V1)		PI	0.5	0.3	-
LC_LTS	LTS liquid level	LTS bottom valve (V2)		P	2	-	-
PC_LTS	LTS pressure	expander power (E-100)		PI	2	10	-
LC_VLS	VLS liquid level	VLS bottom valve (V3)		P	2	-	-
PC_VLS	VLS pressure	VLS overhead valve (V4)		PI	2	10	-
TC_E1	E1 cold-outlet temp	E1 bypass cold stream valve (V7)		PID	3.807	0.318	0.071
TC_E5	E5 cold-outlet temp	E5 bypass cold stream valve (V6)		PID	5.719	0.285	0.063
TC_cooler	LTS inlet temperature	heat duty of exchanger E6		PID	3.628	0.325	0.072
PC_dist	DT overhead pressure	DT overhead valve (V5)		PI	2	10	-
LC_reb	DT base level	CS1	DT base valve (V8)	P	2	-	-
		CS2	E2 bypass cold stream valve (V13)	P	1.5	-	-
FC_stage5	Tray-5 side stream flow rate	Tray-5 side stream valve (V9)		PI	0.3469	0.0084	-
TC_stage6	DT tray-6 temperature	E3 bypass cold stream valve (V10)		PID	29.475	1.203	0.267
FC_stage8	Tray-8 side stream flow rate	Tray-8 side stream valve(V11)		PI	0.3814	0.0083	-
TC_stage9	DT tray-9 temperature	E4 bypass cold stream valve (V12)		PID	18.561	1.695	0.377
CC_21	DT bottom methane mole fraction	CS1	E2 bypass cold stream valve (V13)	PID	5.305	3.993	0.887
		CS3	TC_bottom	PID	2.457	4.525	1.006
TC_bottom	DT bottom temperature	CS2	DT base valve (V8)	PID	10.156	1.965	0.437
		CS3	E2 bypass cold stream valve (V13)	PID	11.349	1.711	0.380

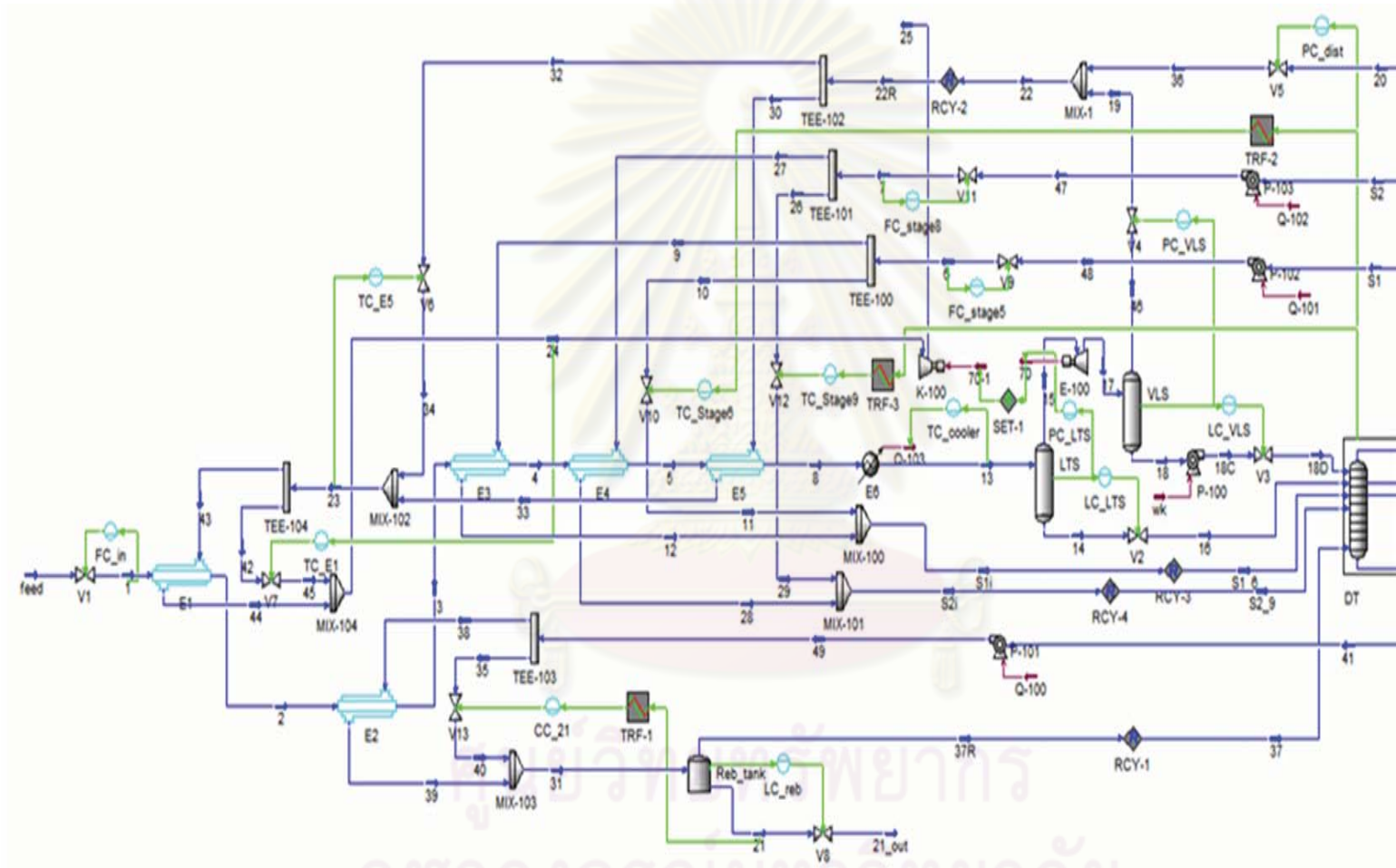

Figure 5.25: Application of the control structure 1 (CS1) to the TEP Alternative 8

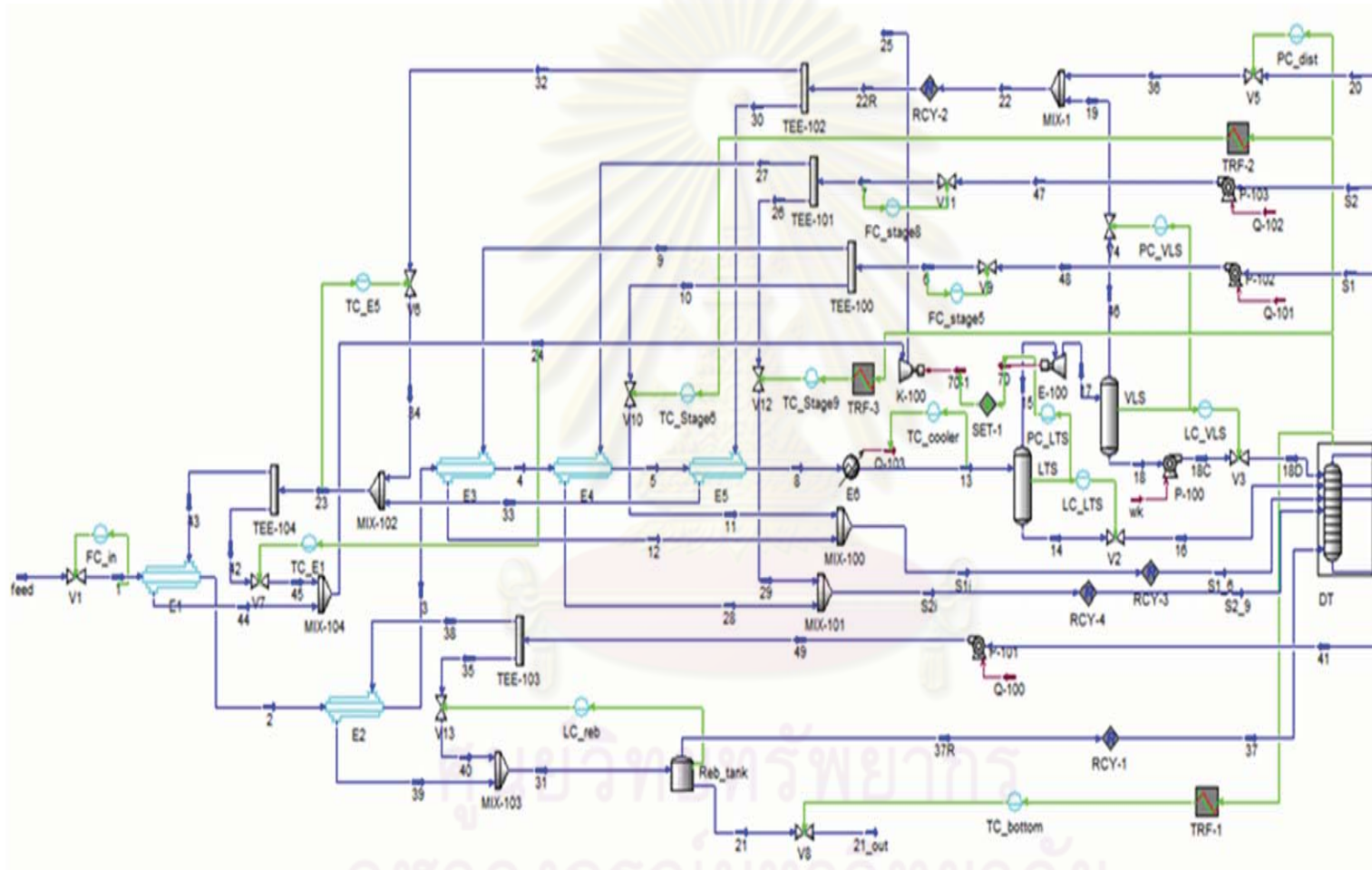

Figure 5.26: Application of the control structure 2 (CS2) to the TEP Alternative 8

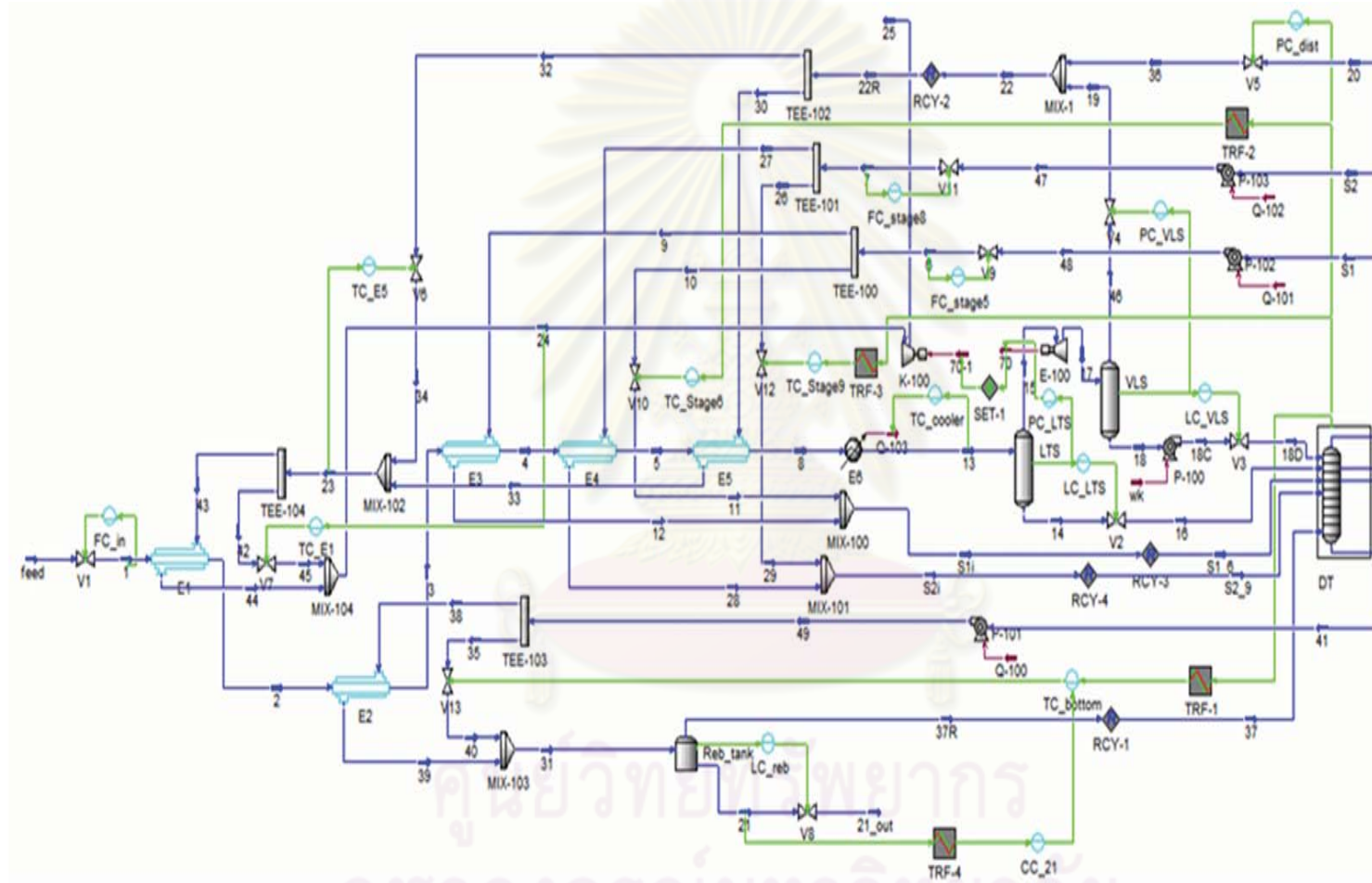

Figure 5.27: Application of the control structure 3 (CS3) to the TEP Alternative 8

5.3 Dynamic Simulation Results

In order to illustrate the dynamic behaviors of the control structures, two kinds of disturbances: thermal and material disturbances are used in evaluation of the plantwide control structures. Two types of disturbance are used to test response of the system: (1) Change in the natural gas feed temperature and (2) Change in the natural gas feed flow rate. Two disturbance loads are used to evaluate the dynamic performance of the control structures (CS1, CS2, and CS3) for the typical and heat-integrated plant of the TEP.

Temperature controllers are PIDs which are tuned using relay feedback. Two temperature measurement lags of 0.5 minute are included in the two temperature loops (6th and 9th tray temperature of Demethanizer Column). Flow and pressure controller are PIs and their parameters are heuristic values. Proportional-only level controllers are used and their parameters are heuristics values. Methane composition is measured and controlled using PID controller. All control valves are half-open at nominal operating condition.

Three control structures (CS1, CS2, and CS3) are implemented on 9 heat-integrated processes which are base case, Alt1, Alt2, Alt3, Alt4, Alt5, alt6, Alt7 and Alt8.

5.3.1 Dynamic Simulation Results for the TEP Base Case

Two disturbance loads are used to evaluate the dynamic performance of the control structures (CS1, CS2 and CS3) for the TEP base case.

Change in the natural gas feed temperature

Figure 5.28, 5.29 and 5.30 show the dynamic responses of the control systems of the TEP base case to a change in the natural gas feed temperature. In

order to make this disturbance, first the natural gas feed temperature is increased from 35.62 °C to 40.62 °C at time equals 10 minutes, and the temperature is decreased from 40.62 °C to 30.62 °C at time equals 210 minutes, then its temperature is returned to its nominal value of 35.62 °C at time equals 410 minutes to 600 minutes (Figure 5.28.a, 5.29.a and 5.30.a).

The three control structures (CS1, CS2 and CS3) give the same result for shifting the thermal disturbance load in natural gas feed stream to cooler as follows. In the first the hot natural gas inlet temperature is increased and then both the hot LTS inlet and methane-rich residue cold outlet temperature of E1 increase suddenly and return to the set point rapidly because these points are controlled. This disturbance load is shifted to the cooler utility. Therefore, the cooler duty will be increased to a new steady state value in this case for all control structures, shown in Figure 5.28.d, 5.29.d and 5.30.d. For decreasing hot natural gas inlet temperature, the hot LTS inlet and methane-rich residue cold outlet temperature of E1 decrease suddenly and return to the set point rapidly. This disturbance load is shifted to the cooler utility. Therefore, the cooler duty will be decreased to a new steady state value in this case.

As can be seen, this disturbance load has a little bit effect to the impurity of methane in the product for all control structures (CS1, CS2 and CS3). However, the CS3 control structure can handle this disturbance load more than CS1 and CS2 control structure because this control structure reaches to the set point faster than others. For control of the DT tray temperature, the tray-6 and tray-9 temperature are well controlled but the dynamic response of CS3 control structure is smoother than CS1 and CS2 control structure.

Change in the natural gas feed flow rate

Figure 5.31, 5.32 and 5.33 show the dynamic responses of the control systems of the TEP base case to a change in the natural gas feed temperature. In

order to make this disturbance, first the natural gas feed temperature is increased from 5000 kmole/hr to 5250 kmole/hr at time equals 10 minutes, and the temperature is decreased from 5250 kmole/hr to 4750 kmole/hr at time equals 210 minutes, then its temperature is returned to its nominal value of 5000 kmole/hr at time equals 410 minutes to 600 minutes (Figure 5.31.a, 5.32.a and 5.33.a).

The dynamic result can be seen that when the hot natural gas flow rate increases, the cooler duty (Q-83) increases to maintain the LTS inlet temperature, and when the hot flow rate decreases, the cooler duty (Q-83) decreases as well. In Figure 5.31.d, 5.32.d and 5.33.d, the cooler duty has overshoot because the LTS inlet temperature has overshoot occurred. For the LTS inlet temperature, CS2 control structure is more oscillatory than CS1 and CS3 control structure.

As can be seen, this disturbance has high effect to impurity of methane in the ethane product for all control structures (CS1, CS2 and CS3). The CS2 control structure for this loop is more oscillatory than CS1 and CS3 control structure. However, the CS3 control structure can handle this disturbance load more than CS1 and CS2 control structure because this control structure reaches to the set point faster than others. For control of the DT tray temperature, the tray-6 and tray-9 temperature are slightly well controlled but tray-9 temperature has oscillation occurred and the dynamic response of CS3 control structure is less oscillatory than CS1 and CS2 control structure. As a result, the dynamic response of CS3 control structure is smoother than CS1 and CS2 control structure.

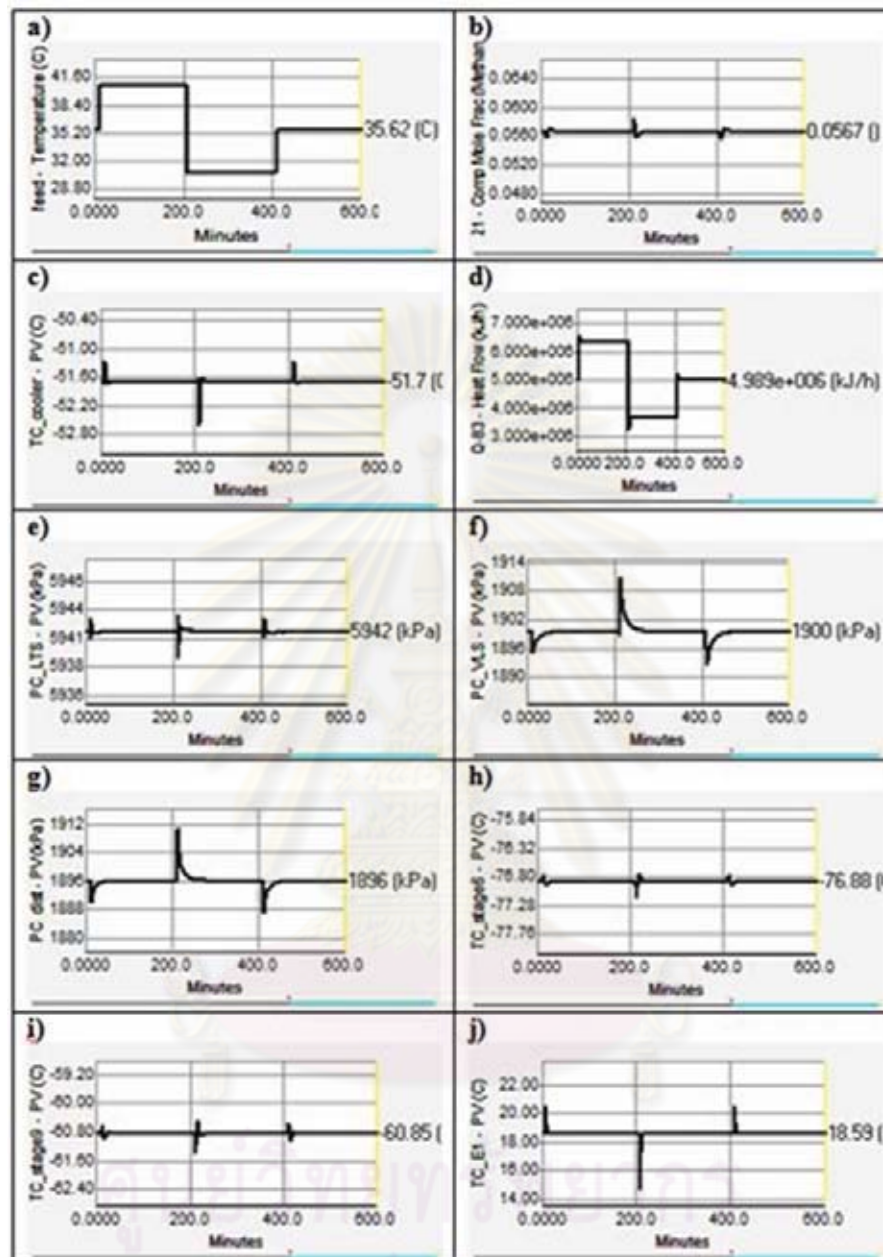

Figure 5.28: Dynamic responses of the natural gas expander plant (Basecase) to a change in the natural gas feed temperature: CS1, where: (a) the variation natural gas feed temperature, (b) the methane impurity of product, (c) the LTS inlet temperature, (d) the cooler duty, (e) the LTS vessel pressure, (f) the VLS vessel pressure, (g) the DT top stage pressure, (h) the 6th stage temperature of DT, (i) the 9th stage temperature of DT, (j) the cold outlet temperature of exchanger E1

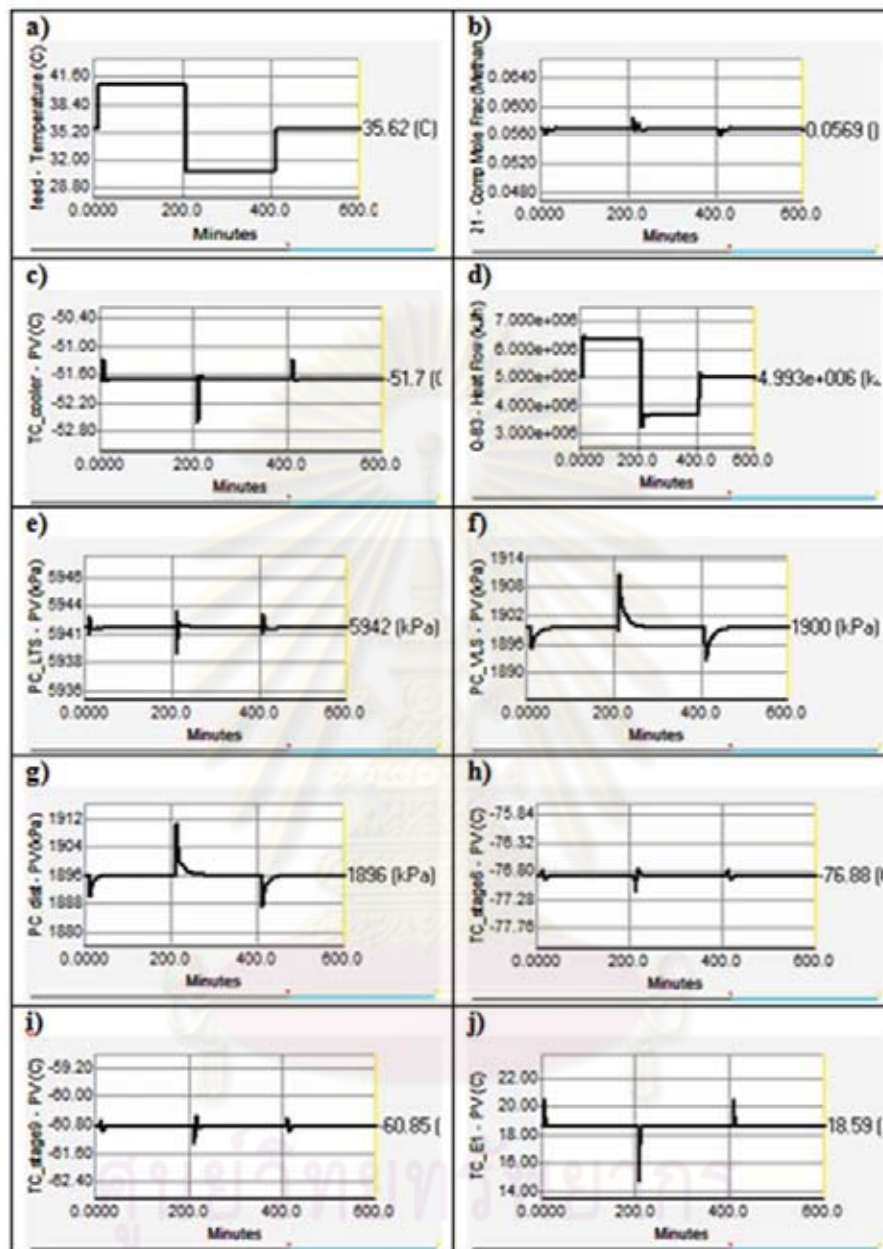

Figure 5.29: Dynamic responses of the natural gas expander plant (Basecase) to a change in the natural gas feed temperature: CS₂, where: (a) the variation natural gas feed temperature, (b) the methane impurity of product, (c) the LTS inlet temperature, (d) the cooler duty, (e) the LTS vessel pressure, (f) the VLS vessel pressure, (g) the DT top stage pressure, (h) the 6th stage temperature of DT, (i) the 9th stage temperature of DT, (j) the cold outlet temperature of exchanger E1

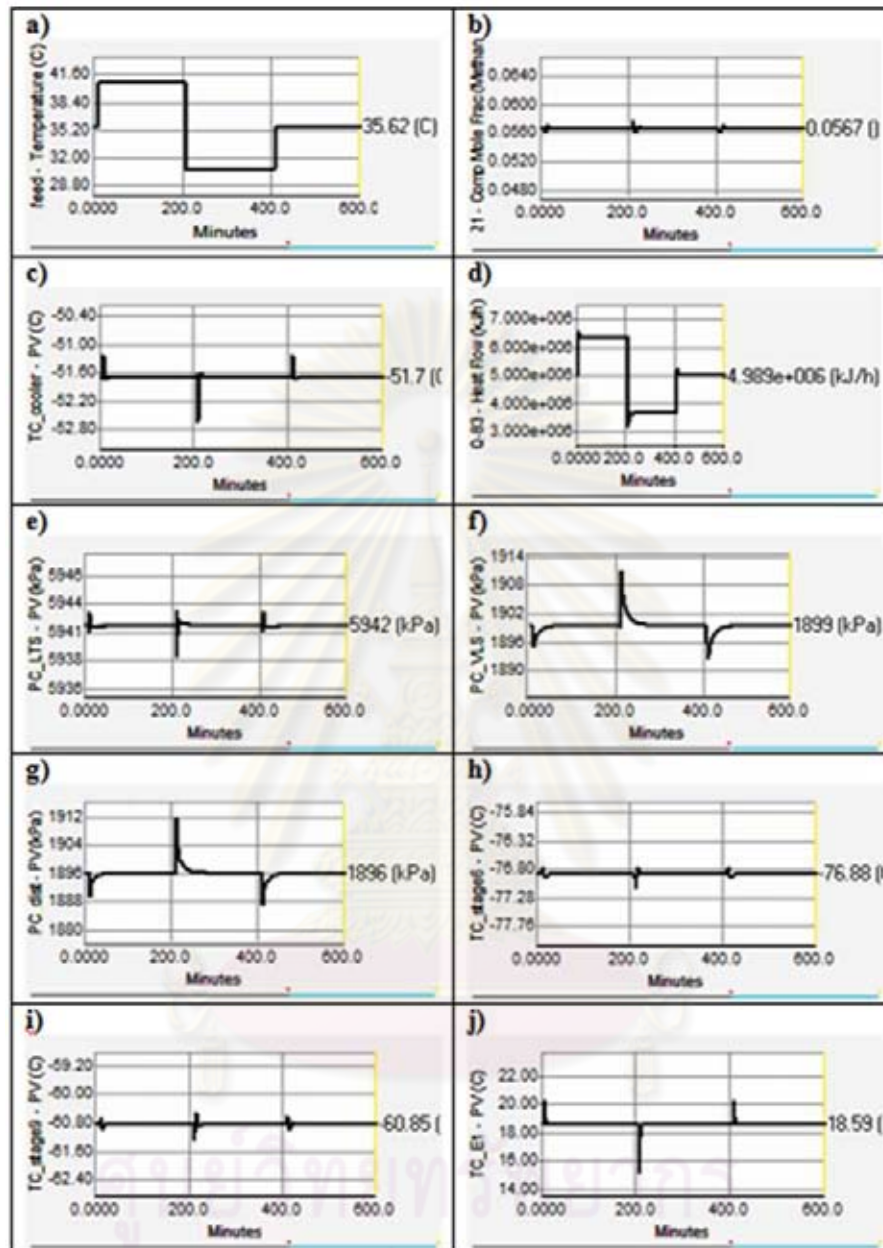

Figure 5.30: Dynamic responses of the natural gas expander plant (Basecase) to a change in the natural gas feed temperature: CS3, where: (a) the variation natural gas feed temperature, (b) the methane impurity of product, (c) the LTS inlet temperature, (d) the cooler duty, (e) the LTS vessel pressure, (f) the VLS vessel pressure, (g) the DT top stage pressure, (h) the 6th stage temperature of DT, (i) the 9th stage temperature of DT, (j) the cold outlet temperature of exchanger E1

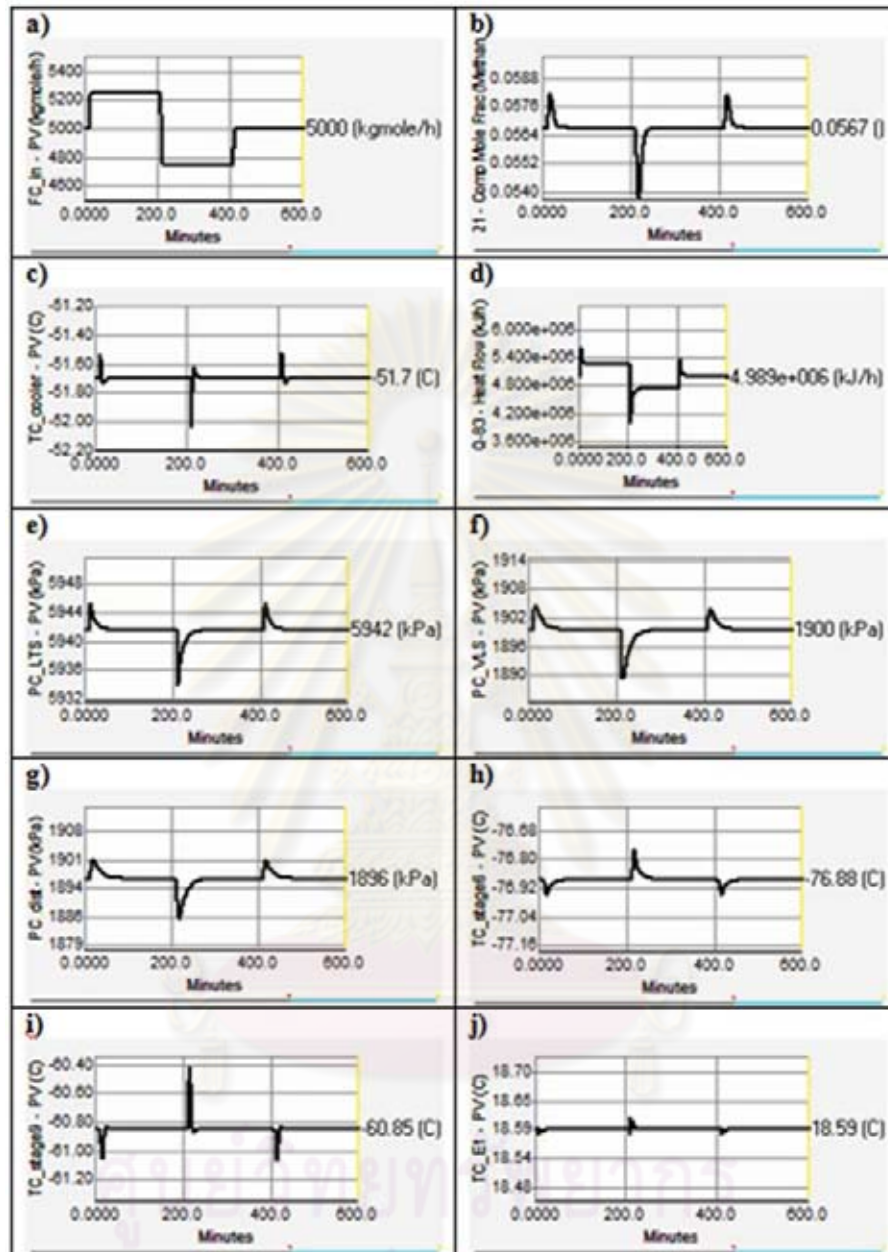

Figure 5.31: Dynamic responses of the natural gas expander plant (Basecase) to a change in the natural gas feed flow rate: CS1, where: (a) the variation natural gas feed flow rate, (b) the methane impurity of product, (c) the LTS inlet temperature, (d) the cooler duty, (e) the LTS vessel pressure, (f) the VLS vessel pressure, (g) the DT top stage pressure, (h) the 6th stage temperature of DT, (i) the 9th stage temperature of DT, (j) the cold outlet temperature of exchanger E1

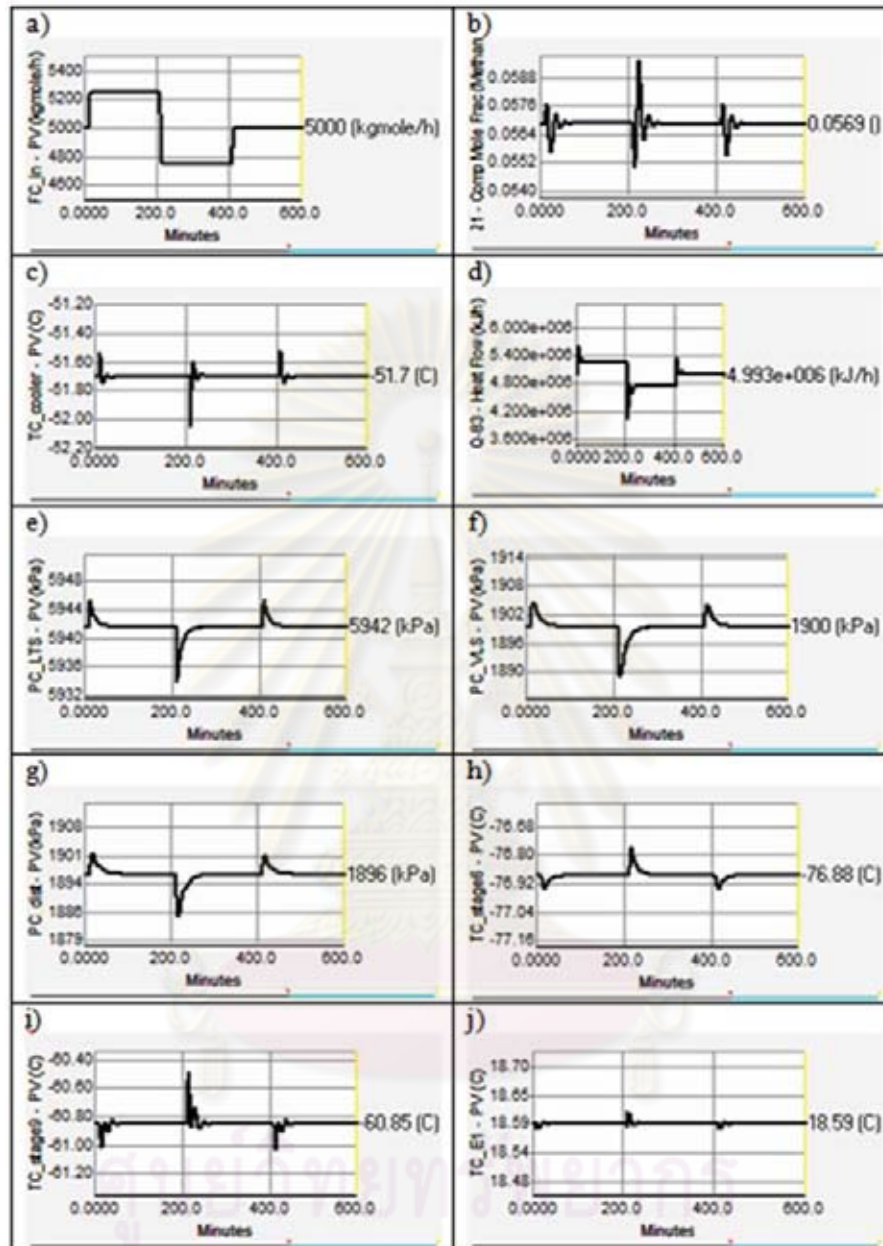

Figure 5.32: Dynamic responses of the natural gas expander plant (Basecase) to a change in the natural gas feed flow rate: CS₂, where: (a) the variation natural gas feed flow rate, (b) the methane impurity of product, (c) the LTS inlet temperature, (d) the cooler duty, (e) the LTS vessel pressure, (f) the VLS vessel pressure, (g) the DT top stage pressure, (h) the 6th stage temperature of DT, (i) the 9th stage temperature of DT, (j) the cold outlet temperature of exchanger E1

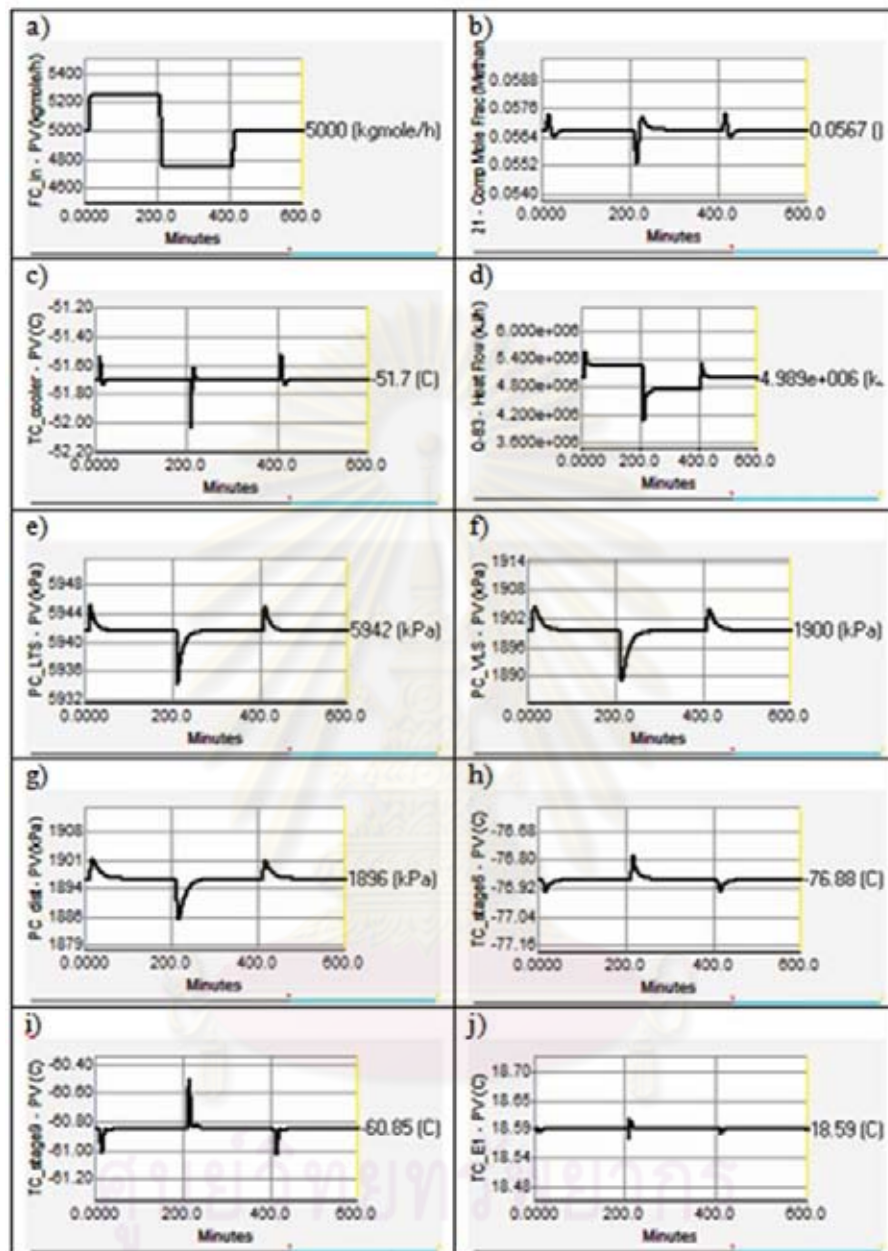

Figure 5.33: Dynamic responses of the natural gas expander plant (Basecase) to a change in the natural gas feed flow rate: CS3, where: (a) the variation natural gas feed flow rate, (b) the methane impurity of product, (c) the LTS inlet temperature, (d) the cooler duty, (e) the LTS vessel pressure, (f) the VLS vessel pressure, (g) the DT top stage pressure, (h) the 6th stage temperature of DT, (i) the 9th stage temperature of DT, (j) the cold outlet temperature of exchanger E1

5.3.2 Dynamic Simulation Results for the TEP Alternative 1

Three disturbance loads are used to evaluate the dynamic performance of the control structures (CS1, CS2 and CS3) for the TEP alternative 1.

Change in the natural gas feed temperature

Figure 5.34, 5.35 and 5.36 show the dynamic responses of the control systems of the TEP alternative 1 to a change in the natural gas feed temperature. In order to make this disturbance, first the natural gas feed temperature is increased from $35.62\text{ }^{\circ}\text{C}$ to $40.62\text{ }^{\circ}\text{C}$ at time equals 10 minutes, and the temperature is decreased from $40.62\text{ }^{\circ}\text{C}$ to $30.62\text{ }^{\circ}\text{C}$ at time equals 210 minutes, then its temperature is returned to its nominal value of $35.62\text{ }^{\circ}\text{C}$ at time equals 410 minutes to 600 minutes (Figure 5.34.a, 5.35.a and 5.36.a).

The three control structures (CS1, CS2 and CS3) give the same result for shifting the thermal disturbance load in natural gas feed stream to cooler as follows. In the first, the hot natural gas inlet temperature is increased and then both the hot LTS inlet temperature and methane-rich residue cold outlet temperature of E1 increase suddenly and return to the set point rapidly because these points are controlled. This disturbance load is shifted to the cooler utility. Therefore, the cooler duty will be increased to a new steady state value in this case for all control structures, shown in Figure 5.34.d, 5.35.d and 5.36.d. For decreasing hot natural gas inlet temperature, the hot LTS inlet and methane-rich residue cold outlet temperature of E1 decrease suddenly and return to the set point rapidly. This disturbance load is shifted to the cooler utility. Therefore, the cooler duty will be decreased to a new steady state value in this case.

As can be seen, this disturbance load has an effect to the impurity of methane in the product more than the base case alternative for all control struc-

tures (CS1, CS2 and CS3). The CS2 control structure for this loop is oscillatory and return to the set point. However, the CS3 control structure can handle this disturbance load more than CS1 and CS2 control structure because this control structure reaches to the set point faster than others. For control of the DT tray temperature, the tray-6 and tray-9 temperature are well controlled. However, the dynamic response of CS3 control structure is smoother than CS1 and CS2 control structure.

Change in the natural gas feed flow rate

Figure 5.37, 5.38 and 5.39 show the dynamic responses of the control systems of the TEP alternative 1 to a change in the natural gas feed temperature. In order to make this disturbance, first the natural gas feed temperature is increased from 5000 kmole/hr to 5250 kmole/hr at time equals 10 minutes, and the temperature is decreased from 5250 kmole/hr to 4750 kmole/hr at time equals 210 minutes, then its temperature is returned to its nominal value of 5000 kmole/hr at time equals 410 minutes to 600 minutes (Figure 5.37.a, 5.38.a and 5.39.a).

The dynamic result can be seen that when the hot natural gas flow rate increases, the cooler duty (Q-83) increases to maintain the LTS inlet temperature, and when the hot flow rate decreases, the cooler duty (Q-83) decreases as well. In Figure 5.37.d, 5.38.d and 5.39.d, the cooler duty has overshoot which is similar to the base case alternative. For the LTS inlet temperature, CS2 control structure is more oscillatory than CS1 and CS3 control structure. However, the dynamic response of alternative 1 is better than the dynamic response of base case in this load.

As can be seen, this disturbance has a little bit effect to impurity of methane in the ethane product for all control structures (CS1, CS2 and CS3). The CS2 control structure for this loop has oscillation and reaches to the set point lower than CS1 and CS3 control structure. Therefore, the CS3 control structure

can handle this disturbance load more than CS1 and CS2 control structure. For control of the DT tray temperature, the tray-6 and tray-9 temperature are slightly well controlled. However, the dynamic response of CS3 control structure reaches to the set point faster than CS1 and CS2 control structure. As a result, the dynamic response of CS3 control structure is smoother than CS1 and CS2 control structure.

5.3.3 Dynamic Simulation Results for the TEP Alternative 2

Three disturbance loads are used to evaluate the dynamic performance of the control structures (CS1, CS2 and CS3) for the TEP alternative 2.

Change in the natural gas feed temperature

Figure 5.40, 5.41 and 5.42 show the dynamic responses of the control systems of the TEP alternative 2 to a change in the natural gas feed temperature. In order to make this disturbance, first the natural gas feed temperature is increased from $35.62\text{ }^{\circ}\text{C}$ to $40.62\text{ }^{\circ}\text{C}$ at time equals 10 minutes, and the temperature is decreased from $40.62\text{ }^{\circ}\text{C}$ to $30.62\text{ }^{\circ}\text{C}$ at time equals 210 minutes, then its temperature is returned to its nominal value of $35.62\text{ }^{\circ}\text{C}$ at time equals 410 minutes to 600 minutes (Figure 5.40.a, 5.41.a and 5.42.a).

The three control structures (CS1, CS2 and CS3) give the same result for shifting the thermal disturbance load in natural gas feed stream to cooler as follows. The dynamic responses of alternative 2 are similar to those of alternative 1 for all loops in the process but all control structures of alternative 2 have the response a little better than alternative 1.

As can be seen, this disturbance load has an effect to the impurity of methane in the product less than the alternative 1 for all control structures (CS1,

CS2 and CS3). The responses of composition and tray temperature loop in this alternative are similar to those in alternative 1.

Change in the natural gas feed flow rate

Figure 5.43, 5.44 and 5.45 show the dynamic responses of the control systems of the TEP alternative 2 to a change in the natural gas feed temperature. In order to make this disturbance, first the natural gas feed temperature is increased from 5000 kmole/hr to 5250 kmole/hr at time equals 10 minutes, and the temperature is decreased from 5250 kmole/hr to 4750 kmole/hr at time equals 210 minutes, then its temperature is returned to its nominal value of 5000 kmole/hr at time equals 410 minutes to 600 minutes (Figure 5.43.a, 5.44.a and 5.45.a).

As can be seen, the responses of this alternative are similar to those of alternative 1 for all control structures (CS1, CS2 and CS3) in each loop. However, the CS3 control structure has the responses better than CS1 and CS2 control structure like the alternative 1.

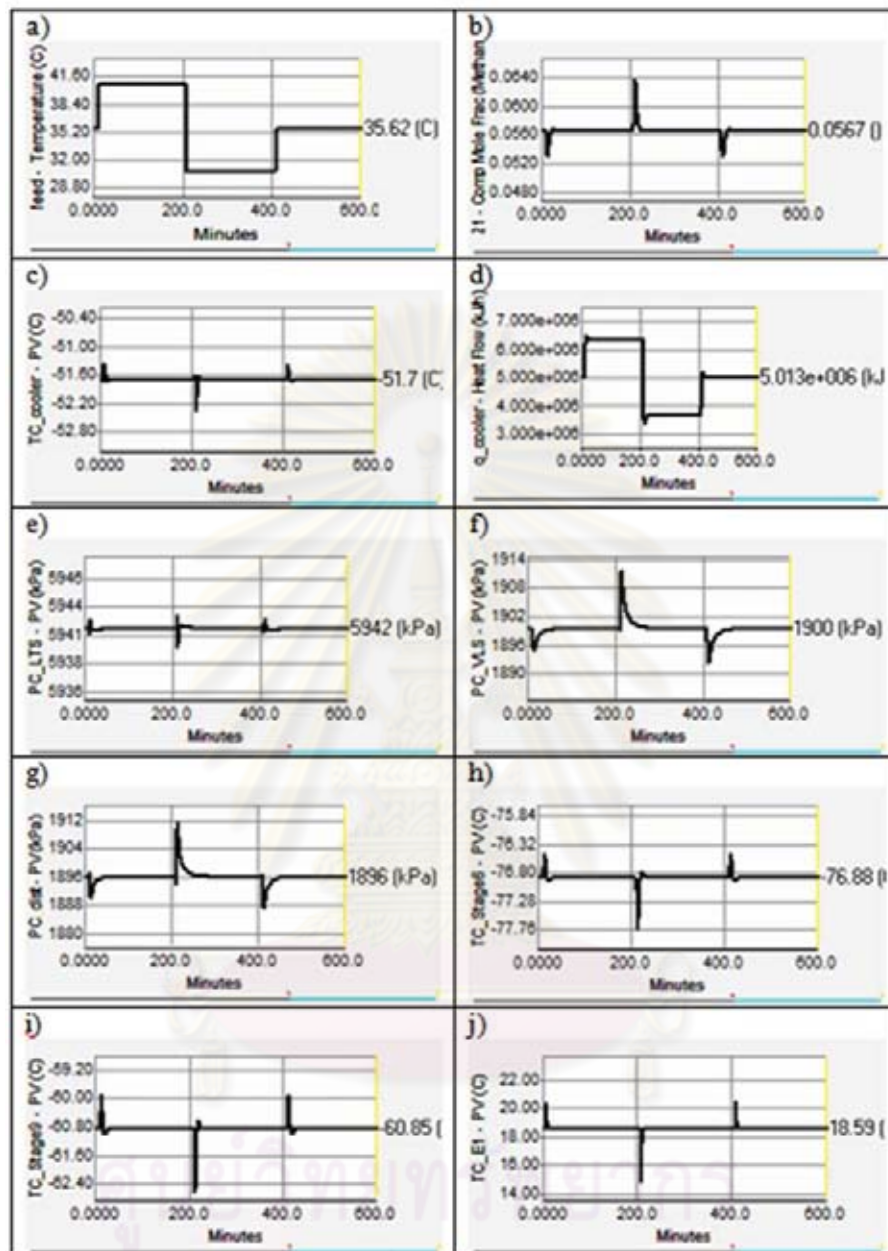

Figure 5.34: Dynamic responses of the natural gas expander plant (Alt1) to a change in the natural gas feed temperature: CS1, where: (a) the variation natural gas feed temperature, (b) the methane impurity of product, (c) the LTS inlet temperature, (d) the cooler duty, (e) the LTS vessel pressure, (f) the VLS vessel pressure, (g) the DT top stage pressure, (h) the 6th stage temperature of DT, (i) the 9th stage temperature of DT, (j) the cold outlet temperature of exchanger E1

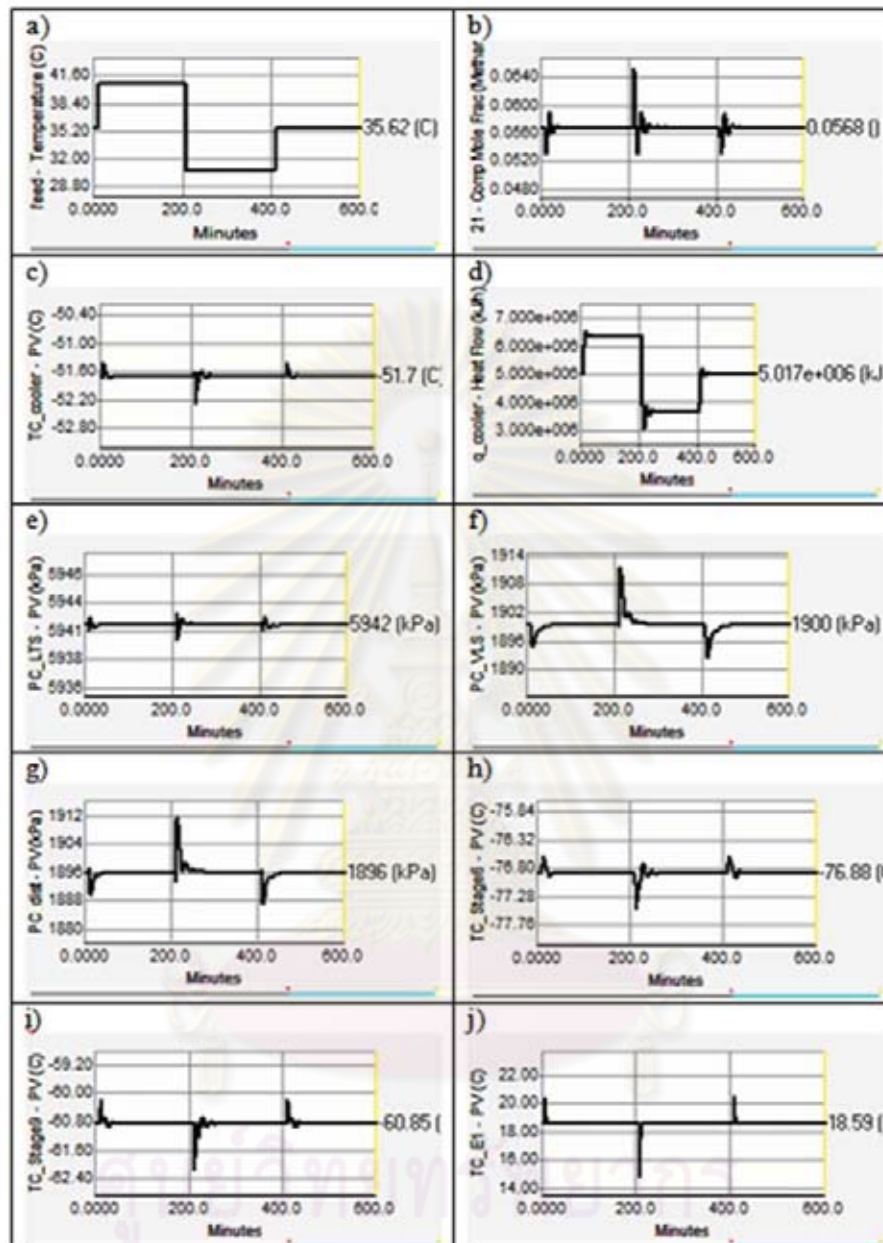

Figure 5.35: Dynamic responses of the natural gas expander plant (Alt1) to a change in the natural gas feed temperature: CS₂, where: (a) the variation natural gas feed temperature, (b) the methane impurity of product, (c) the LTS inlet temperature, (d) the cooler duty, (e) the LTS vessel pressure, (f) the VLS vessel pressure, (g) the DT top stage pressure, (h) the 6th stage temperature of DT, (i) the 9th stage temperature of DT, (j) the cold outlet temperature of exchanger E1

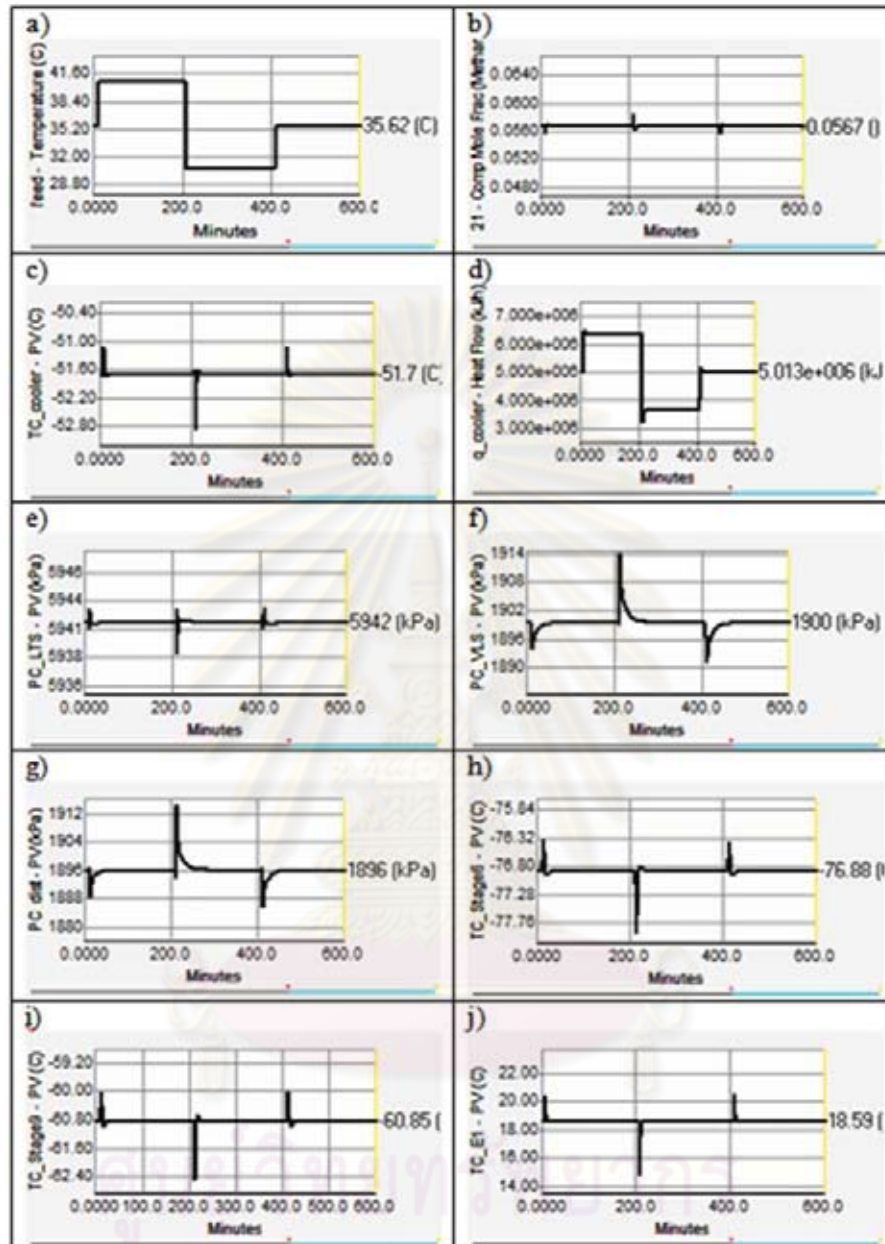

Figure 5.36: Dynamic responses of the natural gas expander plant (Alt1) to a change in the natural gas feed temperature: CS3, where: (a) the variation natural gas feed temperature, (b) the methane impurity of product, (c) the LTS inlet temperature, (d) the cooler duty, (e) the LTS vessel pressure, (f) the VLS vessel pressure, (g) the DT top stage pressure, (h) the 6th stage temperature of DT, (i) the 9th stage temperature of DT, (j) the cold outlet temperature of exchanger E1

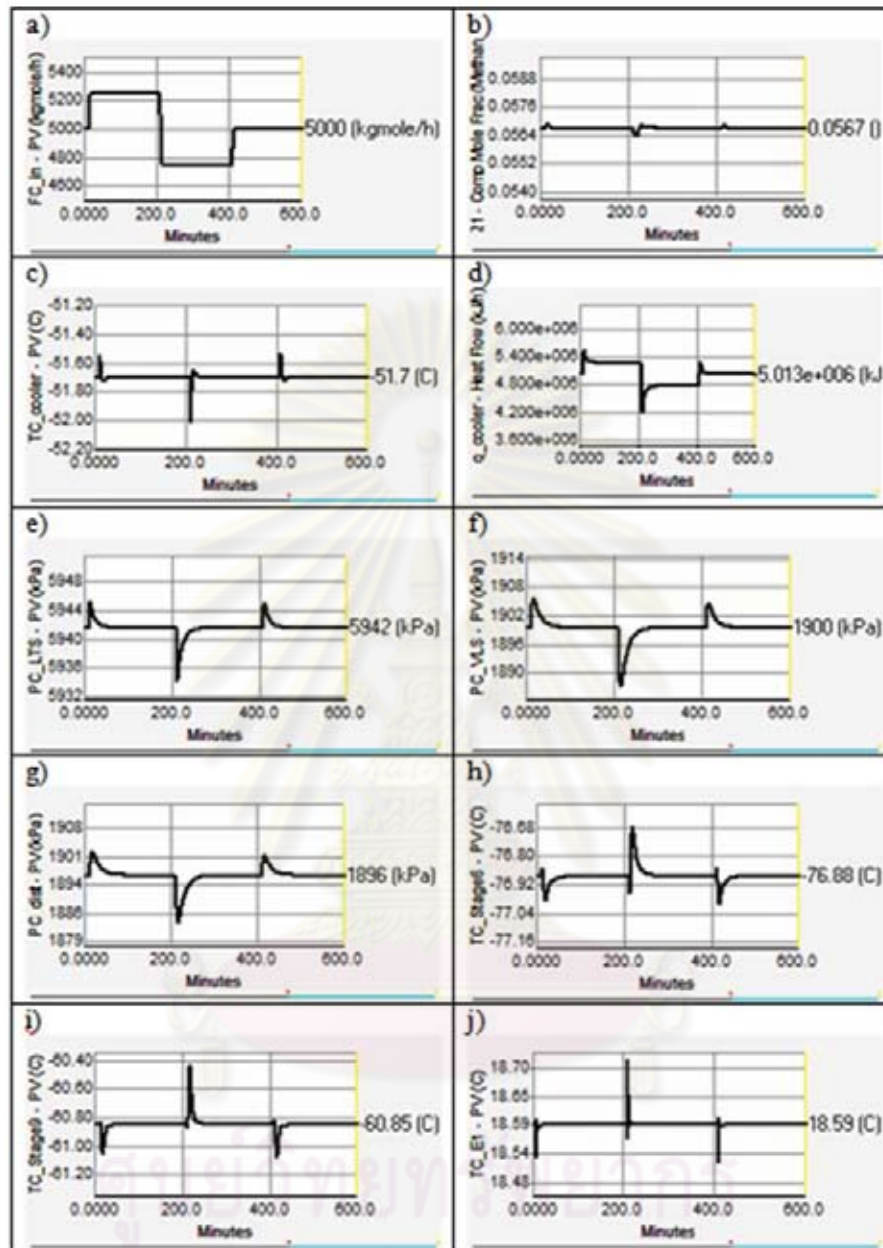

Figure 5.37: Dynamic responses of the natural gas expander plant (Alt1) to a change in the natural gas feed flow rate: CS1, where: (a) the variation natural gas feed flow rate, (b) the methane impurity of product, (c) the LTS inlet temperature, (d) the cooler duty, (e) the LTS vessel pressure, (f) the VLS vessel pressure, (g) the DT top stage pressure, (h) the 6th stage temperature of DT, (i) the 9th stage temperature of DT, (j) the cold outlet temperature of exchanger E1

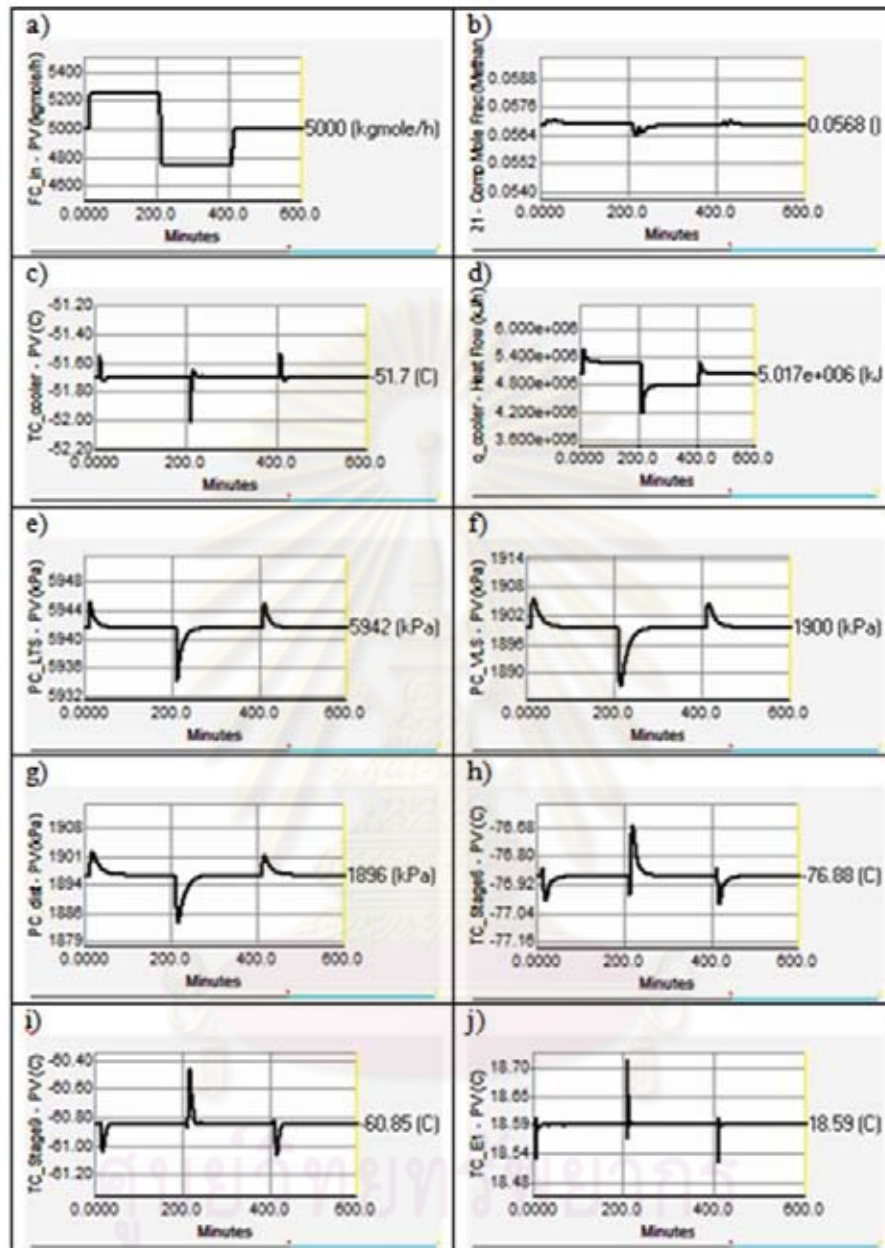

Figure 5.38: Dynamic responses of the natural gas expander plant (Alt1) to a change in the natural gas feed flow rate: CS₂, where: (a) the variation natural gas feed flow rate, (b) the methane impurity of product, (c) the LTS inlet temperature, (d) the cooler duty, (e) the LTS vessel pressure, (f) the VLS vessel pressure, (g) the DT top stage pressure, (h) the 6th stage temperature of DT, (i) the 9th stage temperature of DT, (j) the cold outlet temperature of exchanger E1

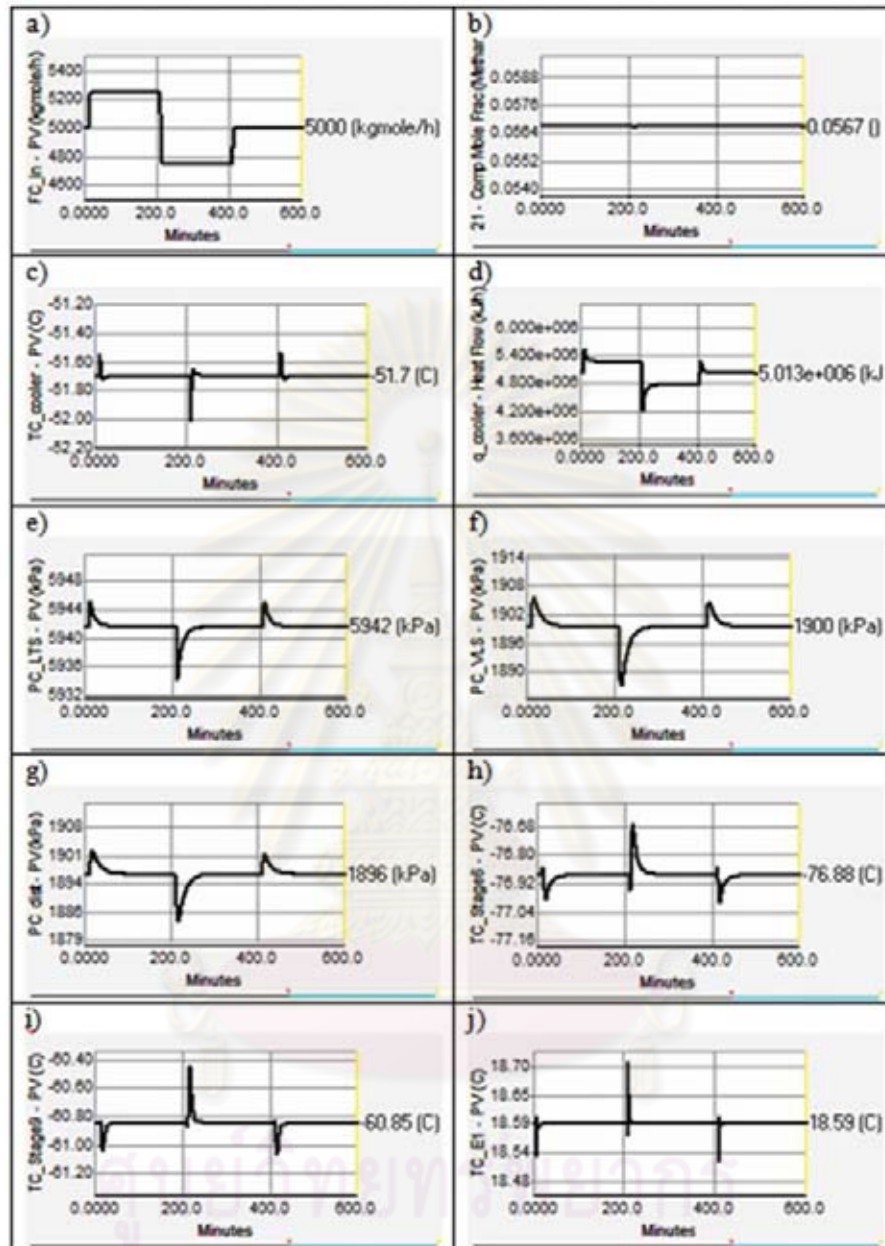

Figure 5.39: Dynamic responses of the natural gas expander plant (Alt1) to a change in the natural gas feed flow rate: CS3, where: (a) the variation natural gas feed flow rate, (b) the methane impurity of product, (c) the LTS inlet temperature, (d) the cooler duty, (e) the LTS vessel pressure, (f) the VLS vessel pressure, (g) the DT top stage pressure, (h) the 6th stage temperature of DT, (i) the 9th stage temperature of DT, (j) the cold outlet temperature of exchanger E1

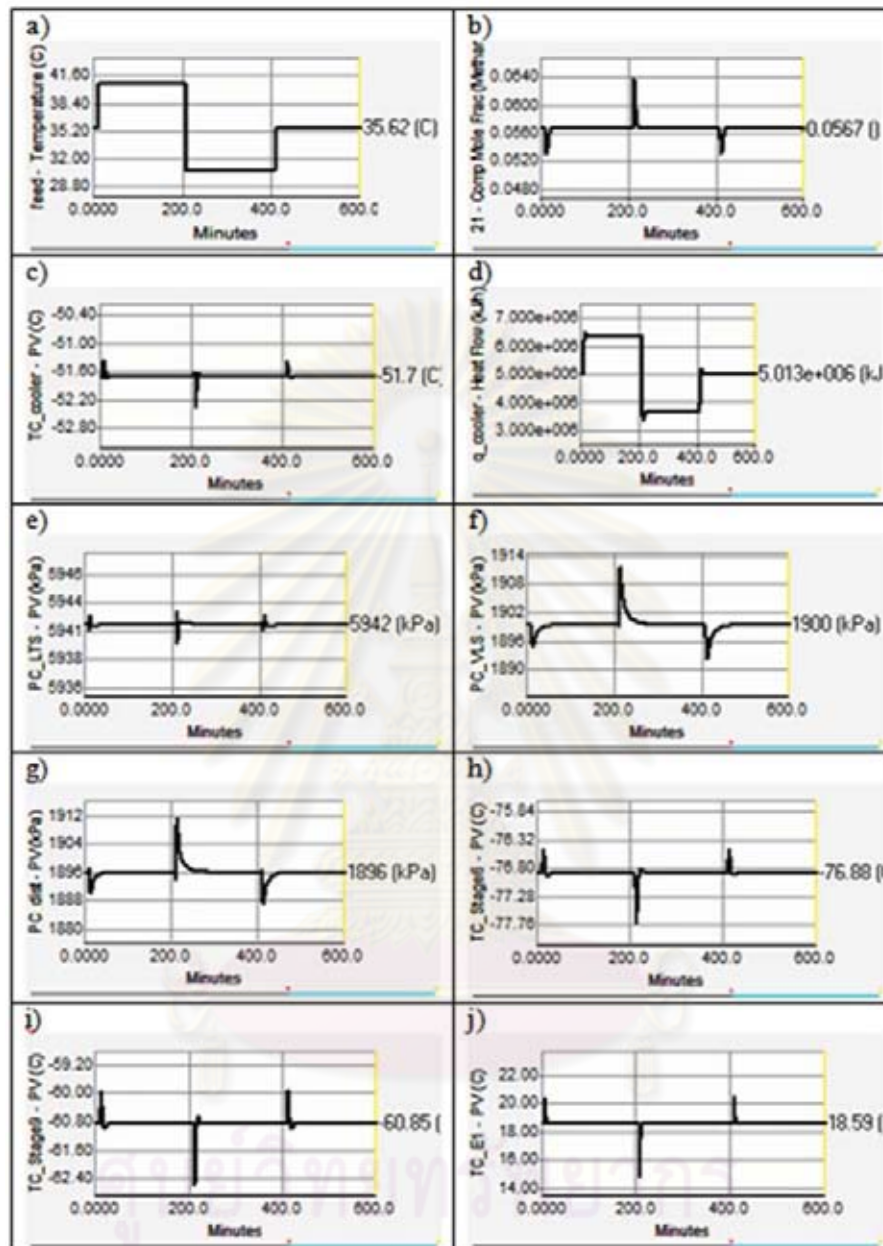

Figure 6.40: Dynamic responses of the natural gas expander plant (Alt2) to a change in the natural gas feed temperature: CS1, where: (a) the variation natural gas feed temperature, (b) the methane impurity of product, (c) the LTS inlet temperature, (d) the cooler duty, (e) the LTS vessel pressure, (f) the VLS vessel pressure, (g) the DT top stage pressure, (h) the 6th stage temperature of DT, (i) the 9th stage temperature of DT, (j) the cold outlet temperature of exchanger E1

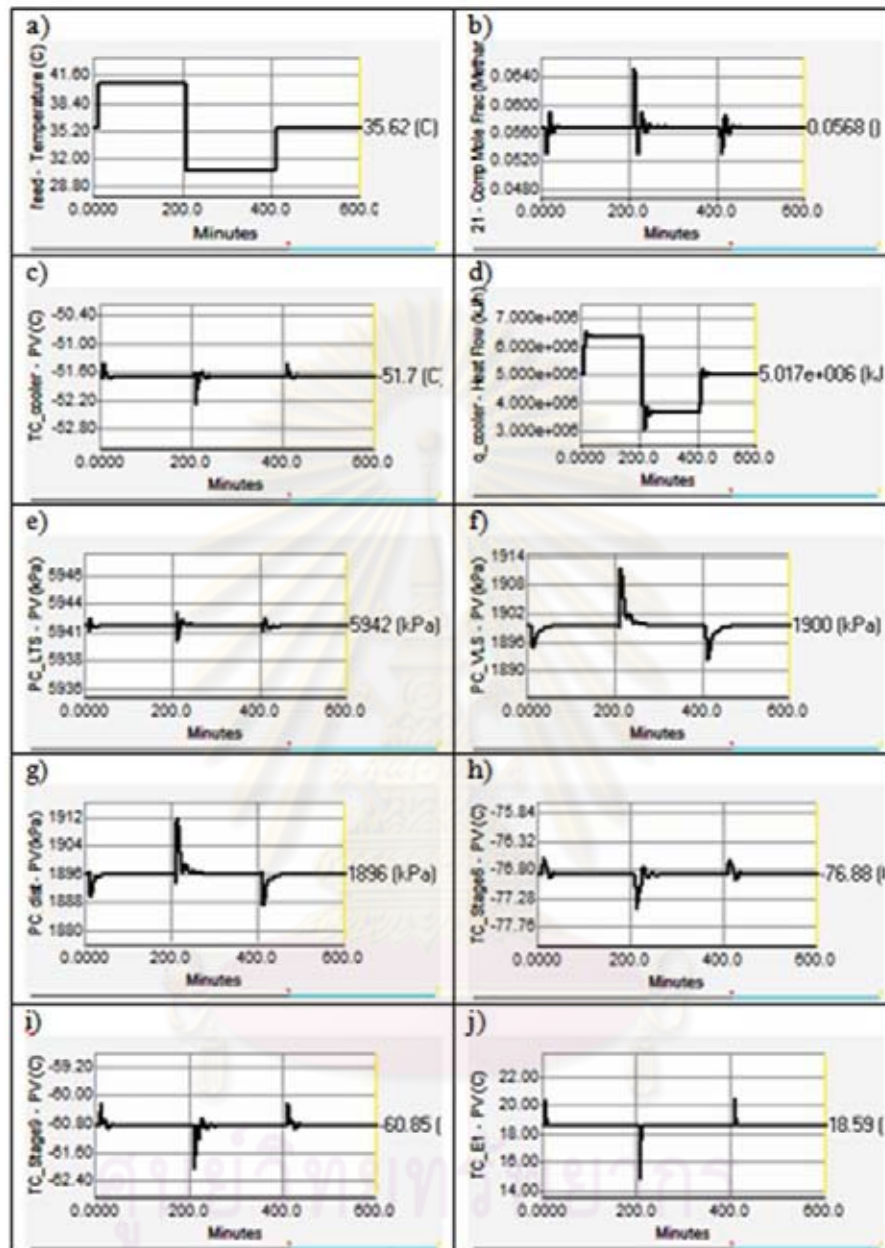

Figure 5.41: Dynamic responses of the natural gas expander plant (Alt2) to a change in the natural gas feed temperature: CS₂, where: (a) the variation natural gas feed temperature, (b) the methane impurity of product, (c) the LTS inlet temperature, (d) the cooler duty, (e) the LTS vessel pressure, (f) the VLS vessel pressure, (g) the DT top stage pressure, (h) the 6th stage temperature of DT, (i) the 9th stage temperature of DT, (j) the cold outlet temperature of exchanger E1

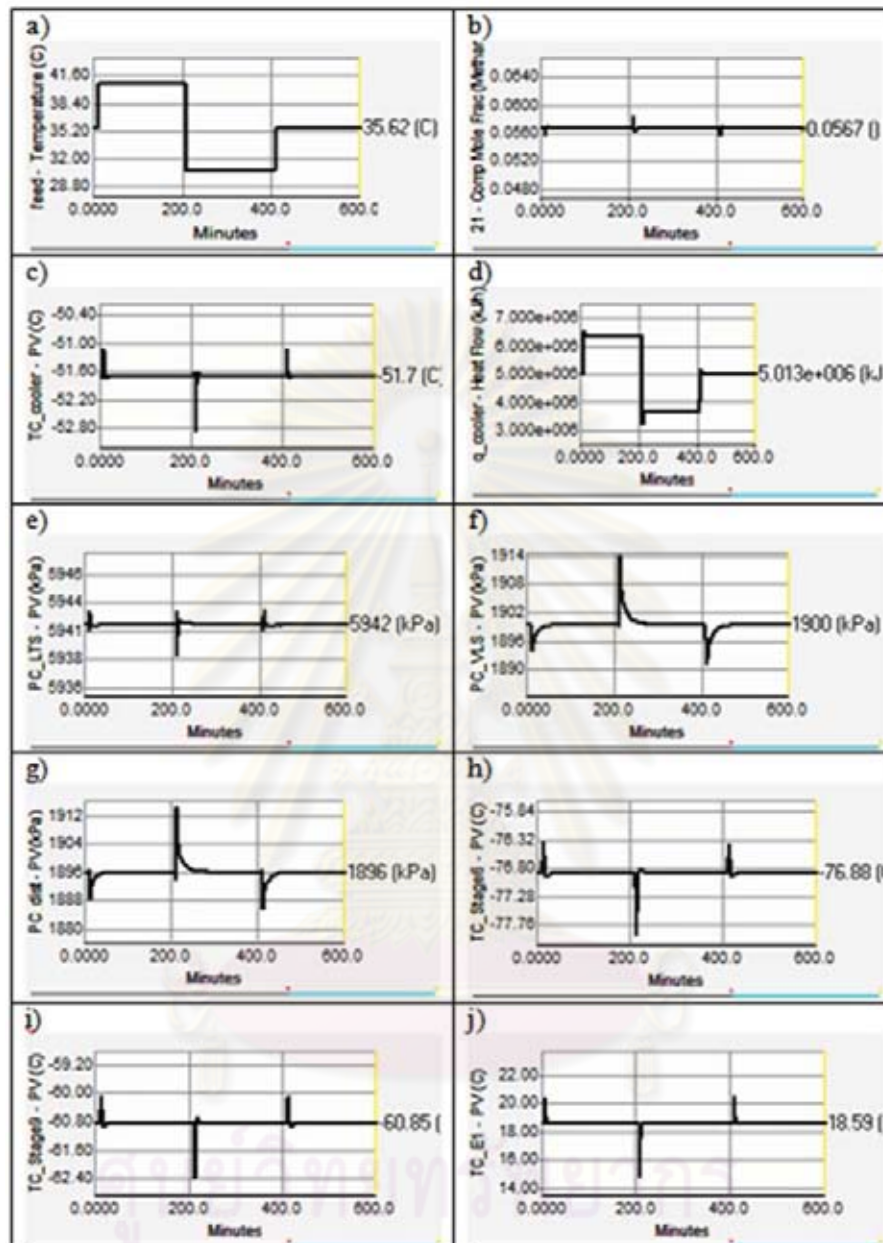

Figure 5.42: Dynamic responses of the natural gas expander plant (Alt2) to a change in the natural gas feed temperature: CS3, where: (a) the variation natural gas feed temperature, (b) the methane impurity of product, (c) the LTS inlet temperature, (d) the cooler duty, (e) the LTS vessel pressure, (f) the VLS vessel pressure, (g) the DT top stage pressure, (h) the 6th stage temperature of DT, (i) the 9th stage temperature of DT, (j) the cold outlet temperature of exchanger E1

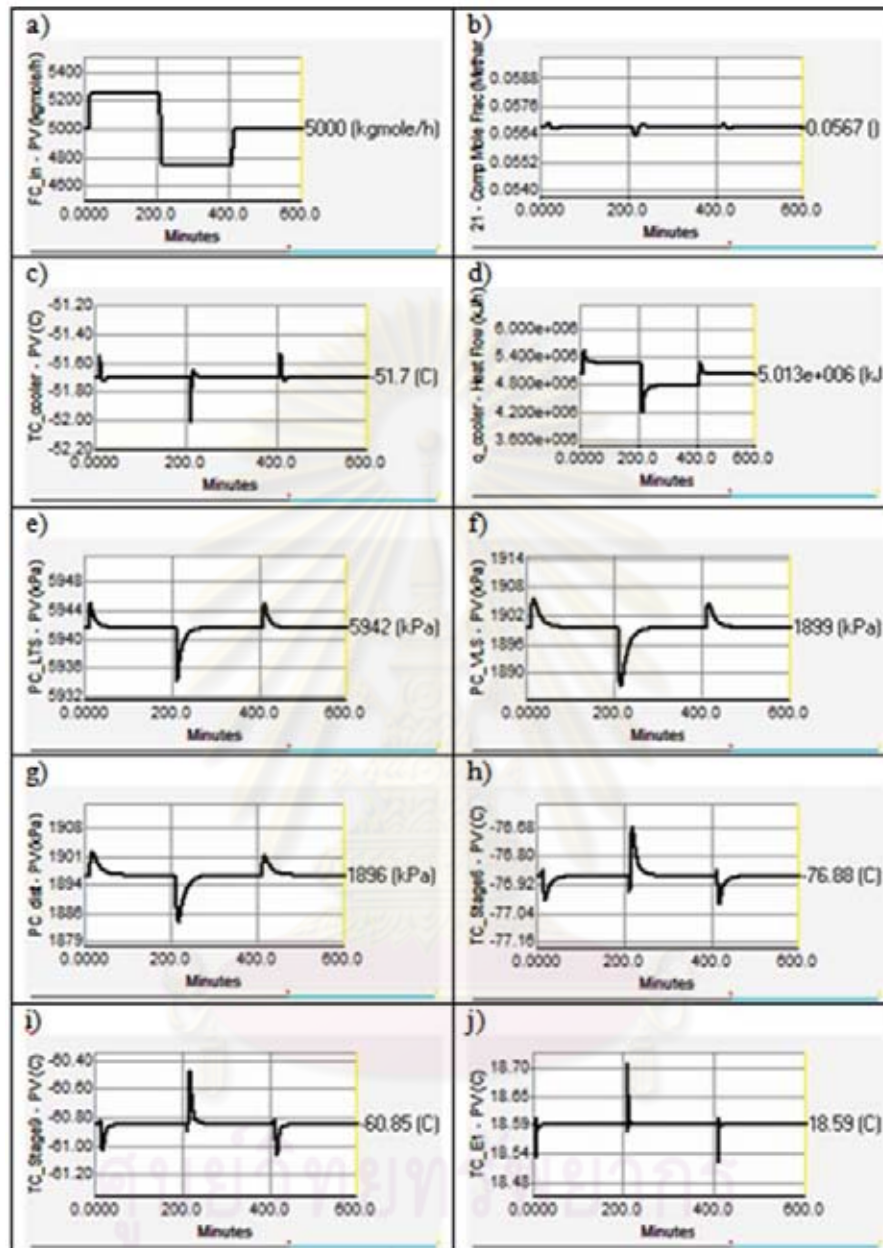

Figure 5.43: Dynamic responses of the natural gas expander plant (Alt2) to a change in the natural gas feed flow rate: CS1, where: (a) the variation natural gas feed flow rate, (b) the methane impurity of product, (c) the LTS inlet temperature, (d) the cooler duty, (e) the LTS vessel pressure, (f) the VLS vessel pressure, (g) the DT top stage pressure, (h) the 6th stage temperature of DT, (i) the 9th stage temperature of DT, (j) the cold outlet temperature of exchanger E1

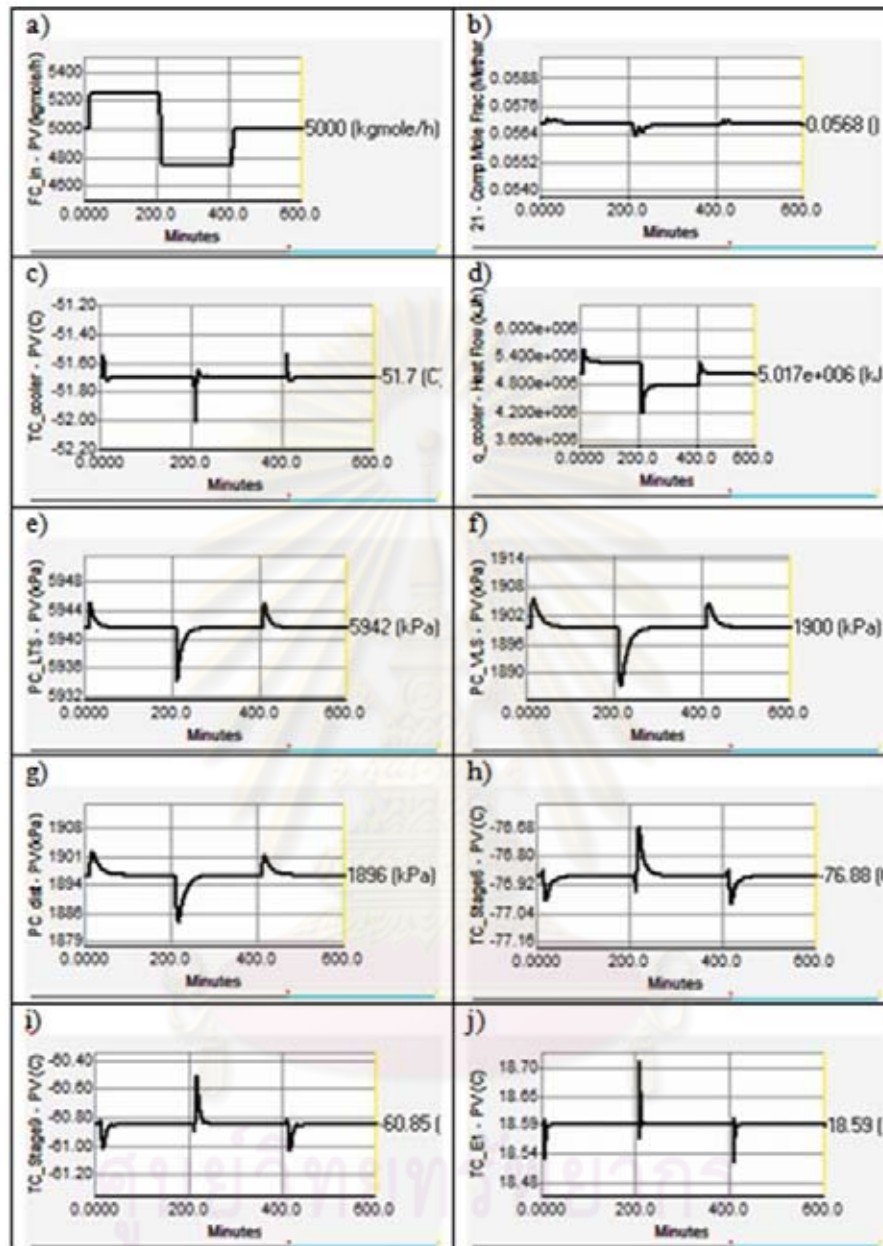

Figure 5.44: Dynamic responses of the natural gas expander plant (Alt2) to a change in the natural gas feed flow rate: CS₂, where: (a) the variation natural gas feed flow rate, (b) the methane impurity of product, (c) the LTS inlet temperature, (d) the cooler duty, (e) the LTS vessel pressure, (f) the VLS vessel pressure, (g) the DT top stage pressure, (h) the 6th stage temperature of DT, (i) the 9th stage temperature of DT, (j) the cold outlet temperature of exchanger E1

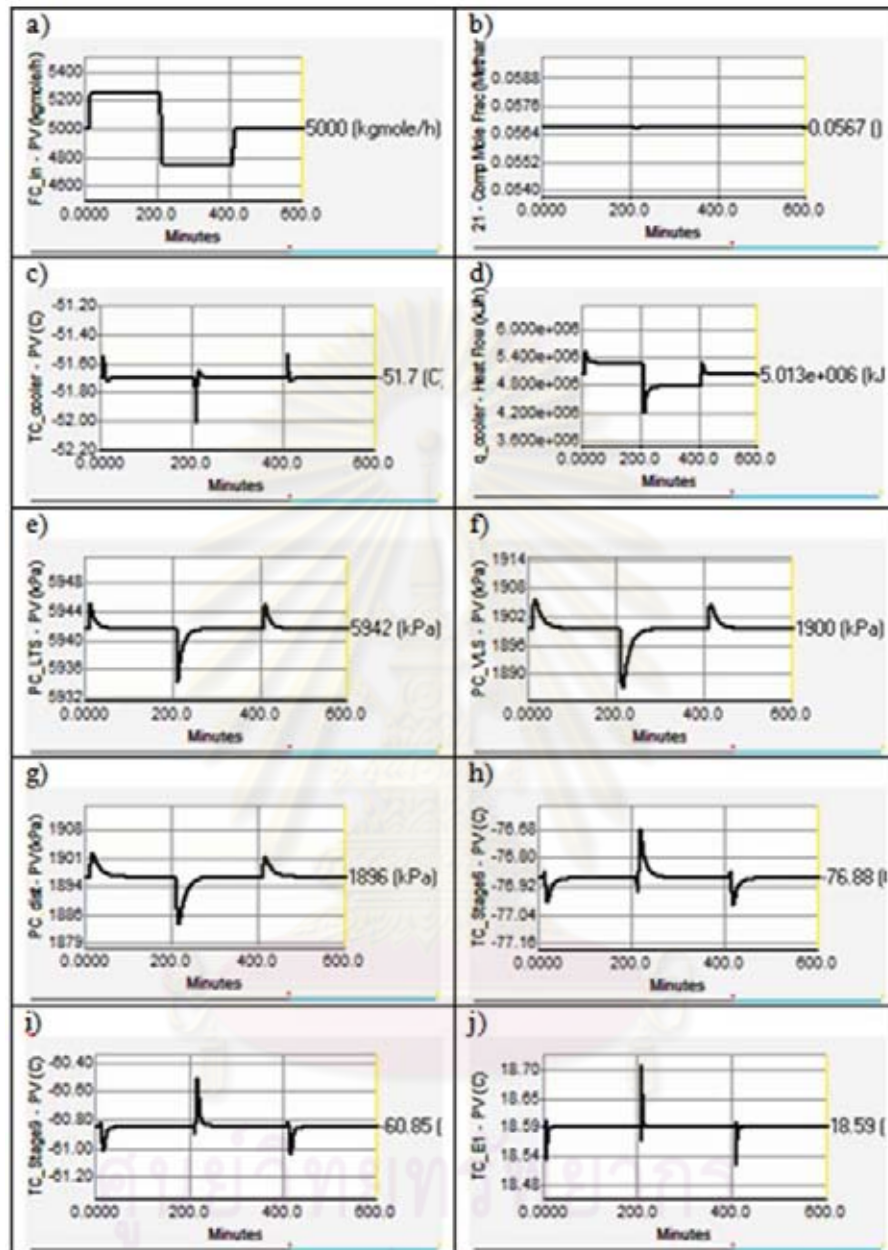

Figure 5.45: Dynamic responses of the natural gas expander plant (Alt2) to a change in the natural gas feed flow rate: CS3, where: (a) the variation natural gas feed flow rate, (b) the methane impurity of product, (c) the LTS inlet temperature, (d) the cooler duty, (e) the LTS vessel pressure, (f) the VLS vessel pressure, (g) the DT top stage pressure, (h) the 6th stage temperature of DT, (i) the 9th stage temperature of DT, (j) the cold outlet temperature of exchanger E1

5.3.4 Dynamic Simulation Results for the TEP Alternative 3

Three disturbance loads are used to evaluate the dynamic performance of the control structures (CS1, CS2 and CS3) for the TEP alternative 3.

Change in the natural gas feed temperature

Figure 5.46, 5.47 and 5.48 show the dynamic responses of the control systems of the TEP alternative 3 to a change in the natural gas feed temperature. In order to make this disturbance, first the natural gas feed temperature is increased from 35.62 °C to 40.62 °C at time equals 10 minutes, and the temperature is decreased from 40.62 °C to 30.62 °C at time equals 210 minutes, then its temperature is returned to its nominal value of 35.62 °C at time equals 410 minutes to 600 minutes (Figure 5.46.a, 5.47.a and 5.48.a).

The three control structures (CS1, CS2 and CS3) give the same result for shifting the thermal disturbance load in natural gas feed stream to cooler as follows. In the first, the hot natural gas inlet temperature is increased and then both the hot LTS inlet temperature and methane-rich residue cold outlet temperature of E1 increase suddenly and return to the set point rapidly. This disturbance load is shifted to the cooler utility. Therefore, the cooler duty will be increased to a new steady state value in this case for all control structures, shown in Figure 5.46.d, 5.47.d and 5.48.d. For decreasing hot natural gas inlet temperature, the hot LTS inlet and methane-rich residue cold outlet temperature of E1 decrease suddenly and return to the set point rapidly. This disturbance load is shifted to the cooler utility. Therefore, the cooler duty will be decreased to a new steady state value in this case. This alternative has responses of three control structures better than alternative 1 and 2.

As can be seen, this disturbance load has a little effect to the impurity of

methane in the product. The CS2 control structure for this loop is oscillatory and return to the set point lower than CS1 and CS3. Therefore, the CS3 control structure can handle this disturbance load more than CS1 and CS2 control structure. For control of the DT tray temperature, the tray-6 and tray-9 temperature are well controlled. However, the dynamic response of CS3 control structure is smoother than CS1 and CS2 control structure.

Change in the natural gas feed flow rate

Figure 5.49, 5.50 and 5.51 show the dynamic responses of the control systems of the TEP alternative 3 to a change in the natural gas feed temperature. In order to make this disturbance, first the natural gas feed temperature is increased from 5000 kmole/hr to 5250 kmole/hr at time equals 10 minutes, and the temperature is decreased from 5250 kmole/hr to 4750 kmole/hr at time equals 210 minutes, then its temperature is returned to its nominal value of 5000 kmole/hr at time equals 410 minutes to 600 minutes (Figure 5.49.a, 5.50.a and 5.51.a). As can be seen, this temperature response is very fast, the new steady state is reached quickly.

The dynamic result can be seen that when the hot natural gas flow rate increases, the cooler duty (Q-83) increases to maintain the LTS inlet temperature, and when the hot flow rate decreases, the cooler duty (Q-83) decreases as well. For the LTS inlet temperature, CS2 control structure has oscillation and reaches to the set point lower than CS1 and CS3 control structure.

As can be seen, this disturbance has a effect to impurity of methane in the ethane product for all control structures (CS1, CS2 and CS3) but it has a effect less than base case and more than alternative 1 and 2. The responses of control structures are similar to above alternative. Therefore, the CS3 control structure can handle this disturbance load more than CS1 and CS2 control structure.

5.3.5 Dynamic Simulation Results for the TEP Alternative 4

Three disturbance loads are used to evaluate the dynamic performance of the control structures (CS1, CS2 and CS3) for the TEP alternative 4.

Change in the natural gas feed temperature

Figure 5.52, 5.53 and 5.54 show the dynamic responses of the control systems of the TEP alternative 4 to a change in the natural gas feed temperature. In order to make this disturbance, first the natural gas feed temperature is increased from 35.62 °C to 40.62 °C at time equals 10 minutes, and the temperature is decreased from 40.62 °C to 30.62 °C at time equals 210 minutes, then its temperature is returned to its nominal value of 35.62 °C at time equals 410 minutes to 600 minutes (Figure 5.52.a, 5.53.a and 5.54.a).

The three control structures (CS1, CS2 and CS3) give the same result for shifting the thermal disturbance load in natural gas feed stream to cooler as follows. The dynamic responses of alternative 4 are similar to those of alternative 3 for all loops in the process but all control structures of alternative 4 have the response better than alternative 3. However, the CS3 control structure has responses better than CS1 and CS2 control structure, and reaches to the set point faster than others.

As can be seen, this disturbance load has a little effect to the impurity of methane in the product. The responses of composition and tray temperature loop in this alternative are similar to those in alternative 3 but it is a little better than alternative 3.

Change in the natural gas feed flow rate

Figure 5.55, 5.56 and 5.57 show the dynamic responses of the control systems of the TEP alternative 4 to a change in the natural gas feed temperature. In order to make this disturbance, first the natural gas feed temperature is increased from 5000 kmole/hr to 5250 kmole/hr at time equals 10 minutes, and the temperature is decreased from 5250 kmole/hr to 4750 kmole/hr at time equals 210 minutes, then its temperature is returned to its nominal value of 5000 kmole/hr at time equals 410 minutes to 600 minutes (Figure 5.55.a, 5.56.a and 5.57.a). As can be seen, this temperature response is very fast, the new steady state is reached quickly.

As can be seen, the responses of this alternative are similar to those of alternative 3 for all control structures (CS1, CS2 and CS3) in each loop. However, the CS3 control structure has the responses better than CS1 and CS2 control structure like the alternative 3 and better than alternative 3 a little. For the tray temperatures in the DT, the responses are slightly well controlled but CS2 is more oscillation than CS1 and CS3. However, the dynamic response of CS3 control structure is smoother than CS1 and CS2 control structure.

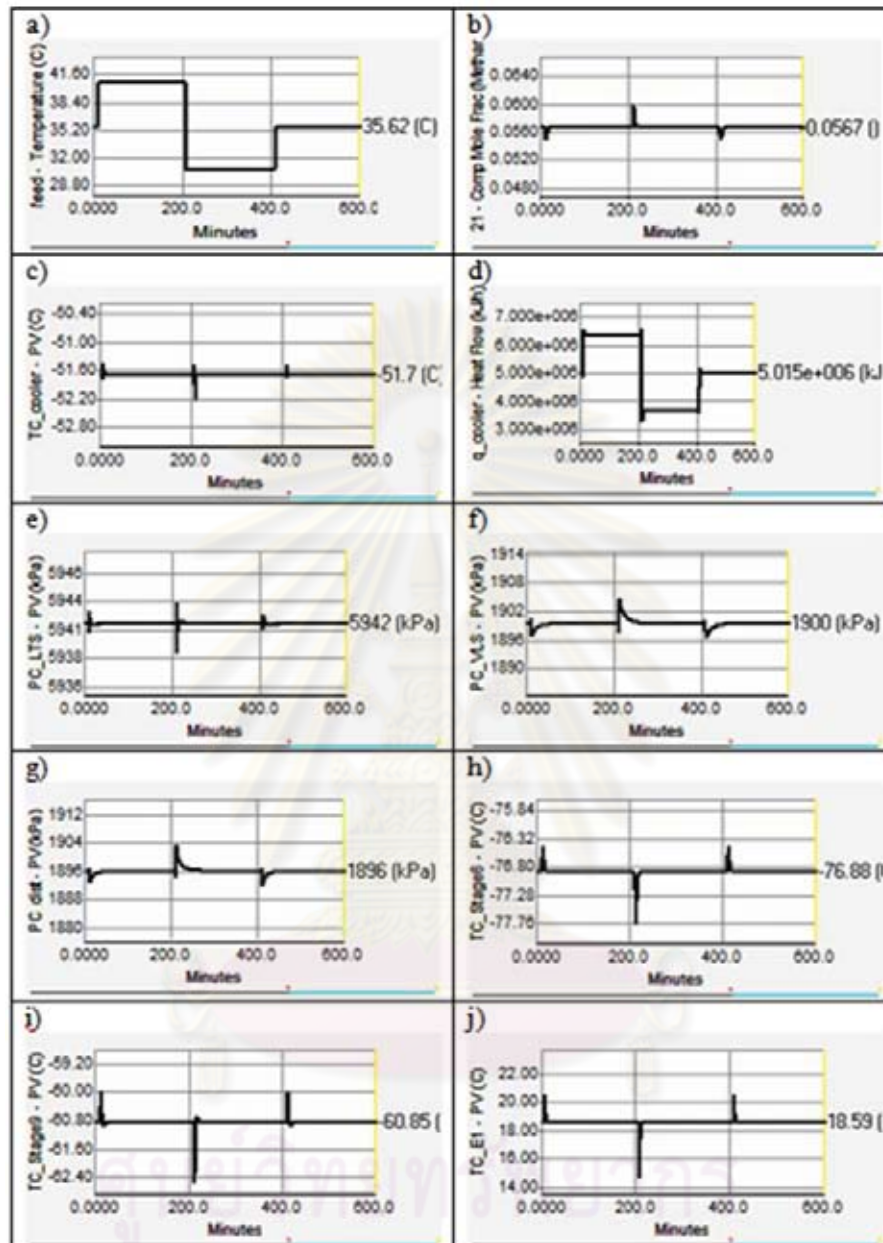

Figure 5.46: Dynamic responses of the natural gas expander plant (Alt3) to a change in the natural gas feed temperature: CS1, where: (a) the variation natural gas feed temperature, (b) the methane impurity of product, (c) the LTS inlet temperature, (d) the cooler duty, (e) the LTS vessel pressure, (f) the VLS vessel pressure, (g) the DT top stage pressure, (h) the 6th stage temperature of DT, (i) the 9th stage temperature of DT, (j) the cold outlet temperature of exchanger E1

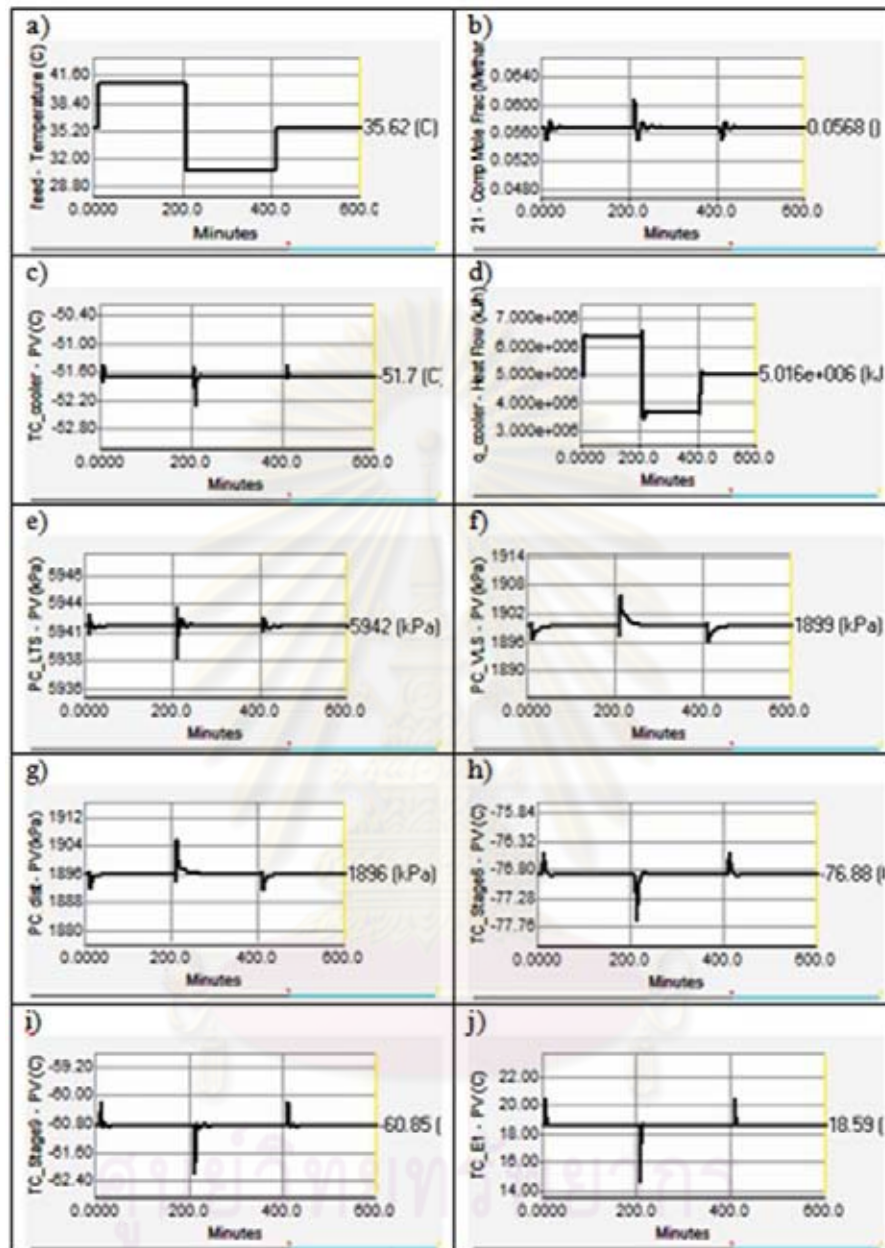

Figure 5.47: Dynamic responses of the natural gas expander plant (Alt3) to a change in the natural gas feed temperature: CS₂, where: (a) the variation natural gas feed temperature, (b) the methane impurity of product, (c) the LTS inlet temperature, (d) the cooler duty, (e) the LTS vessel pressure, (f) the VLS vessel pressure, (g) the DT top stage pressure, (h) the 6th stage temperature of DT, (i) the 9th stage temperature of DT, (j) the cold outlet temperature of exchanger E1

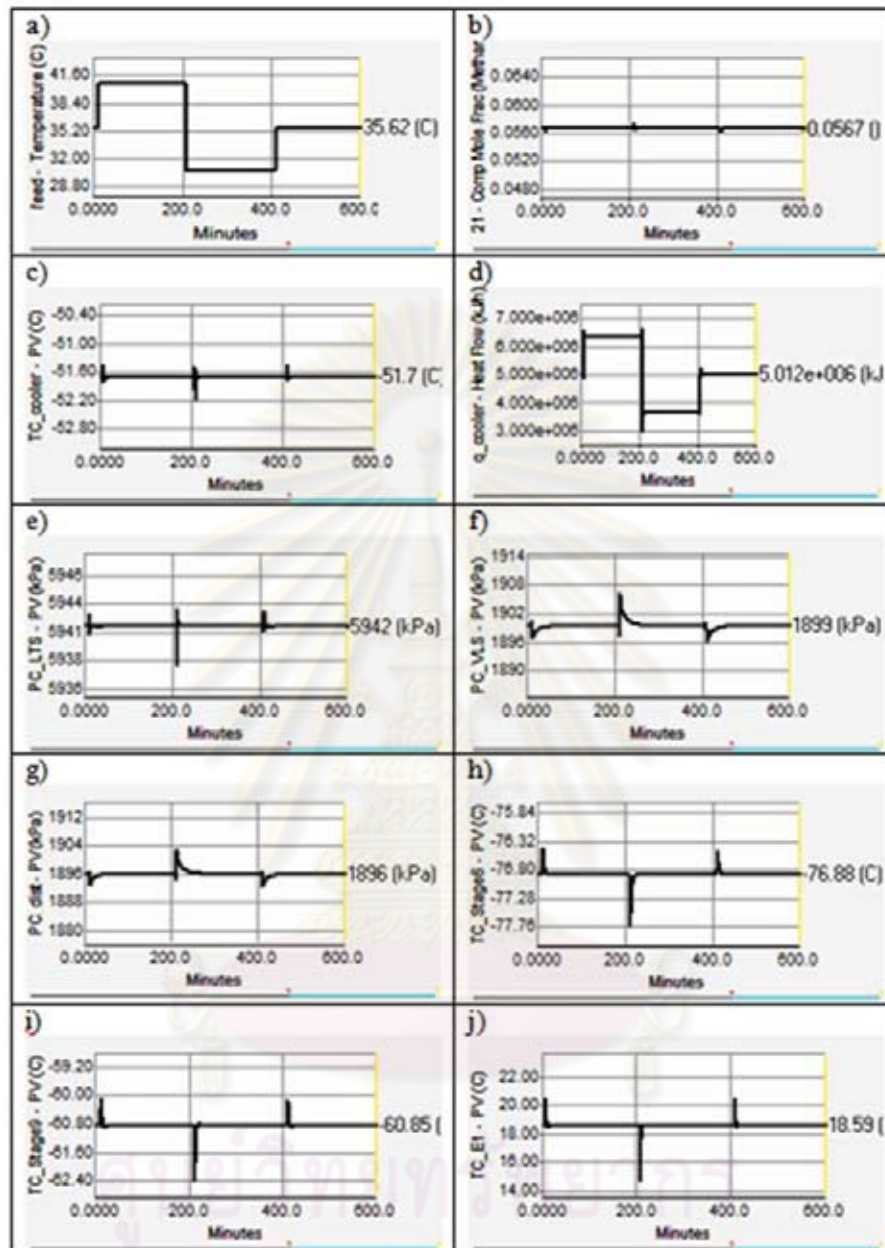

Figure 5.48: Dynamic responses of the natural gas expander plant (Alt3) to a change in the natural gas feed temperature: CS3, where: (a) the variation natural gas feed temperature, (b) the methane impurity of product, (c) the LTS inlet temperature, (d) the cooler duty, (e) the LTS vessel pressure, (f) the VLS vessel pressure, (g) the DT top stage pressure, (h) the 6th stage temperature of DT, (i) the 9th stage temperature of DT, (j) the cold outlet temperature of exchanger E1

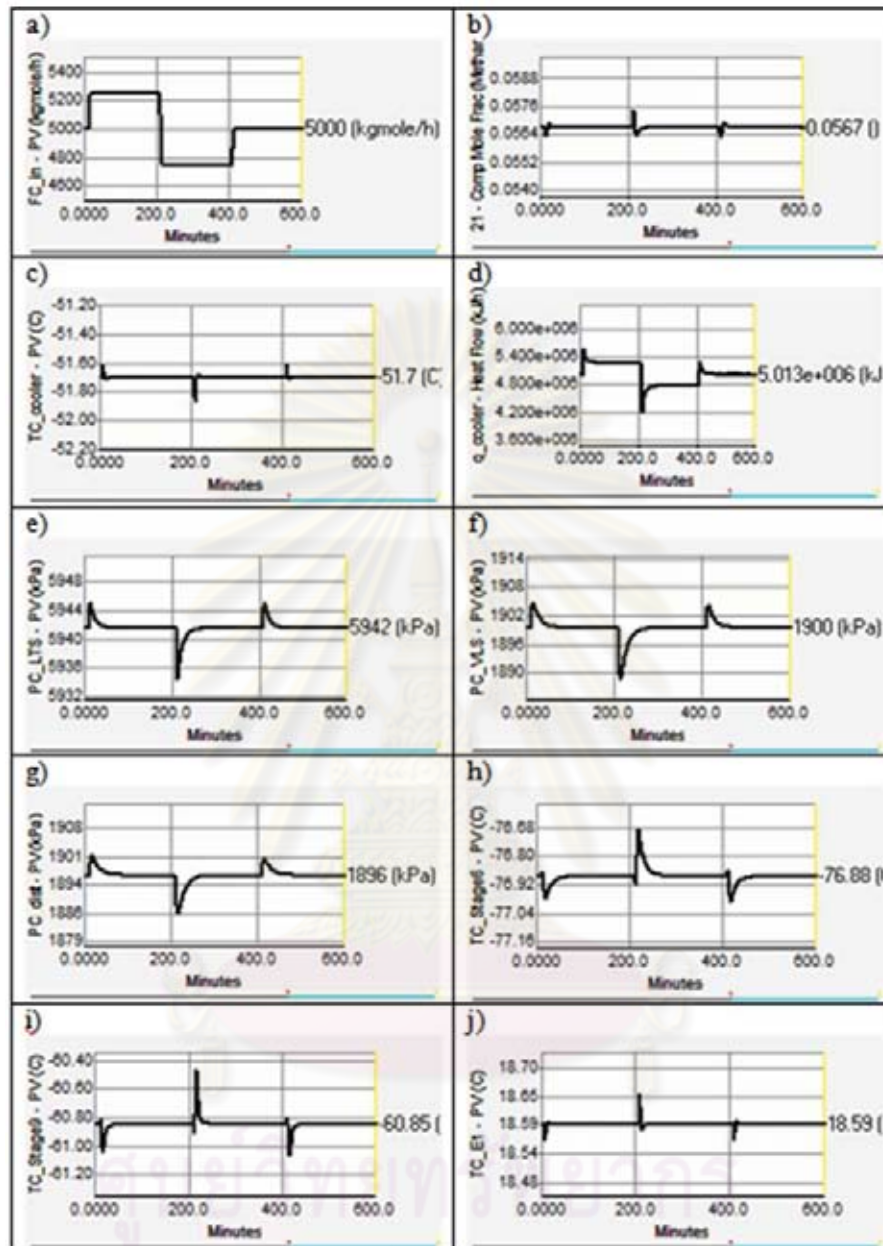

Figure 5.49: Dynamic responses of the natural gas expander plant (Alt3) to a change in the natural gas feed flow rate: CS1, where: (a) the variation natural gas feed flow rate, (b) the methane impurity of product, (c) the LTS inlet temperature, (d) the cooler duty, (e) the LTS vessel pressure, (f) the VLS vessel pressure, (g) the DT top stage pressure, (h) the 6th stage temperature of DT, (i) the 9th stage temperature of DT, (j) the cold outlet temperature of exchanger E1

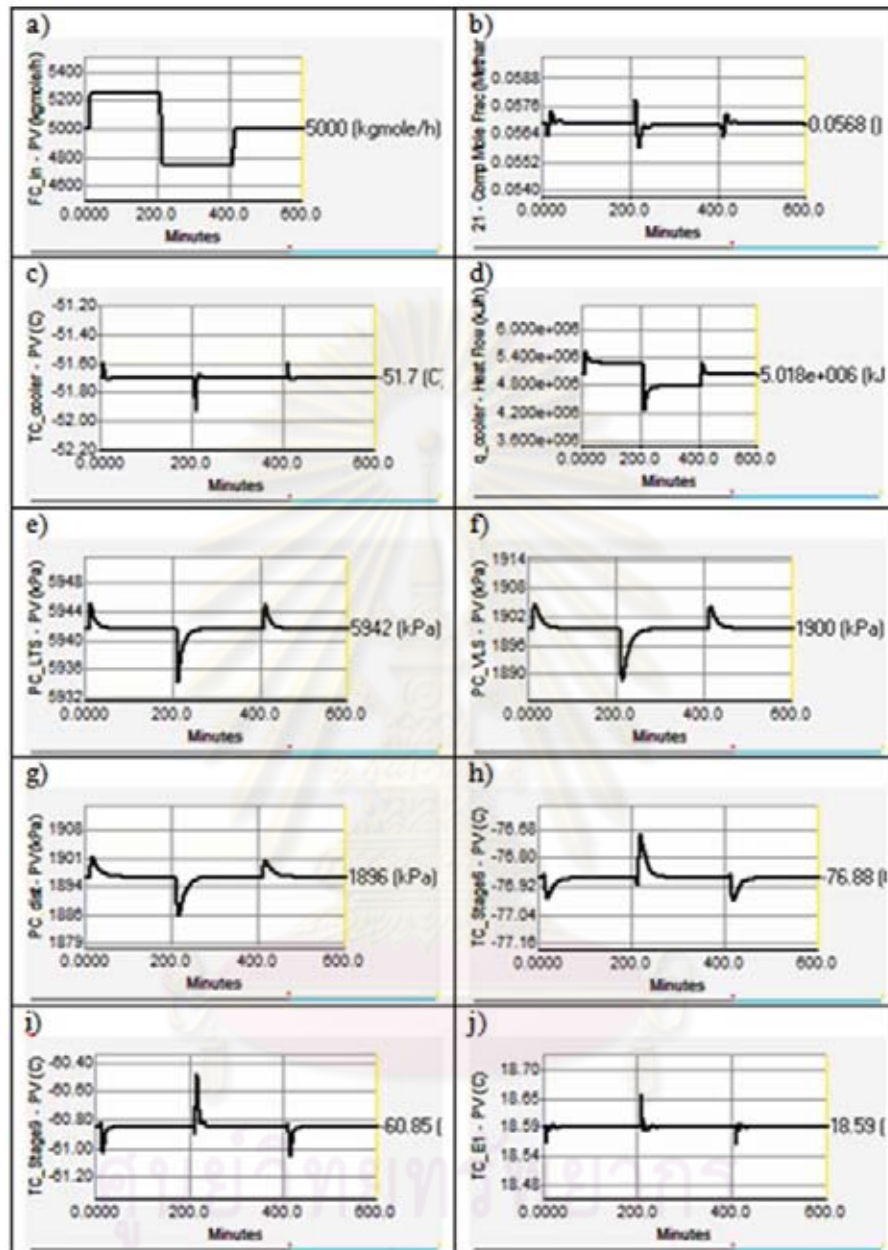

Figure 5.50: Dynamic responses of the natural gas expander plant (Alt3) to a change in the natural gas feed flow rate: CS2, where: (a) the variation natural gas feed flow rate, (b) the methane impurity of product, (c) the LTS inlet temperature, (d) the cooler duty, (e) the LTS vessel pressure, (f) the VLS vessel pressure, (g) the DT top stage pressure, (h) the 6th stage temperature of DT, (i) the 9th stage temperature of DT, (j) the cold outlet temperature of exchanger E1

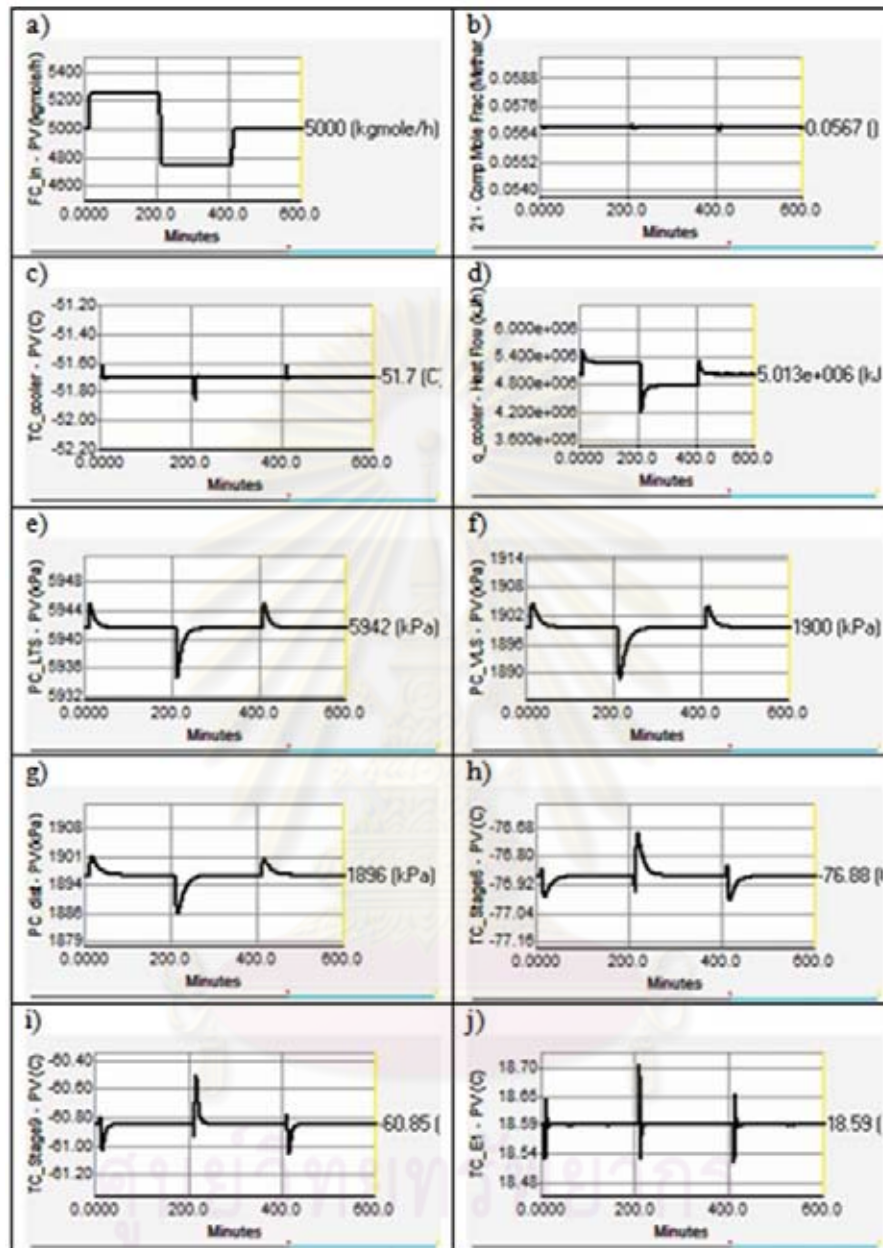

Figure 5.51: Dynamic responses of the natural gas expander plant (Alt3) to a change in the natural gas feed flow rate: CS3, where: (a) the variation natural gas feed flow rate, (b) the methane impurity of product, (c) the LTS inlet temperature, (d) the cooler duty, (e) the LTS vessel pressure, (f) the VLS vessel pressure, (g) the DT top stage pressure, (h) the 6th stage temperature of DT, (i) the 9th stage temperature of DT, (j) the cold outlet temperature of exchanger E1

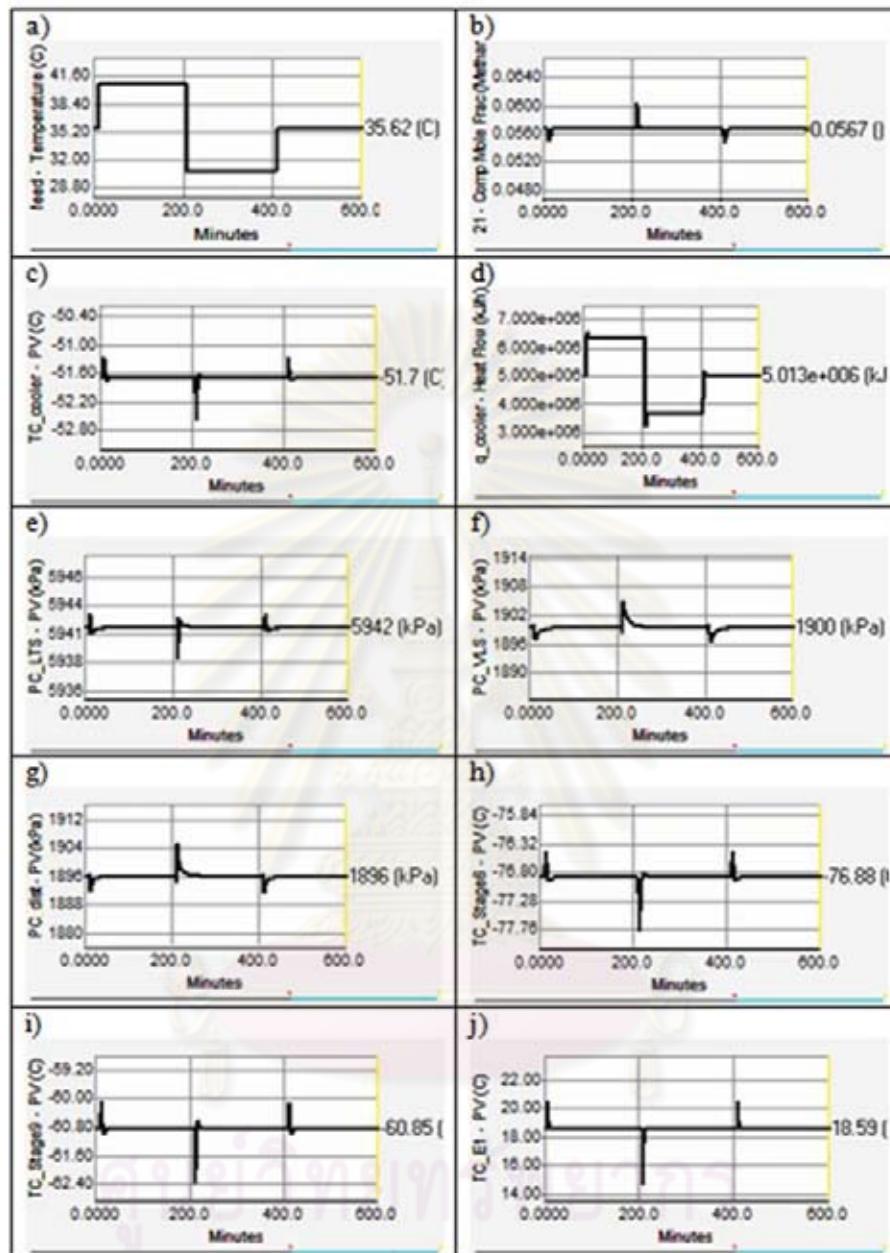

Figure 5.52: Dynamic responses of the natural gas expander plant (Alt4) to a change in the natural gas feed temperature: CS1, where: (a) the variation natural gas feed temperature, (b) the methane impurity of product, (c) the LTS inlet temperature, (d) the cooler duty, (e) the LTS vessel pressure, (f) the VLS vessel pressure, (g) the DT top stage pressure, (h) the 6th stage temperature of DT, (i) the 9th stage temperature of DT, (j) the cold outlet temperature of exchanger E1

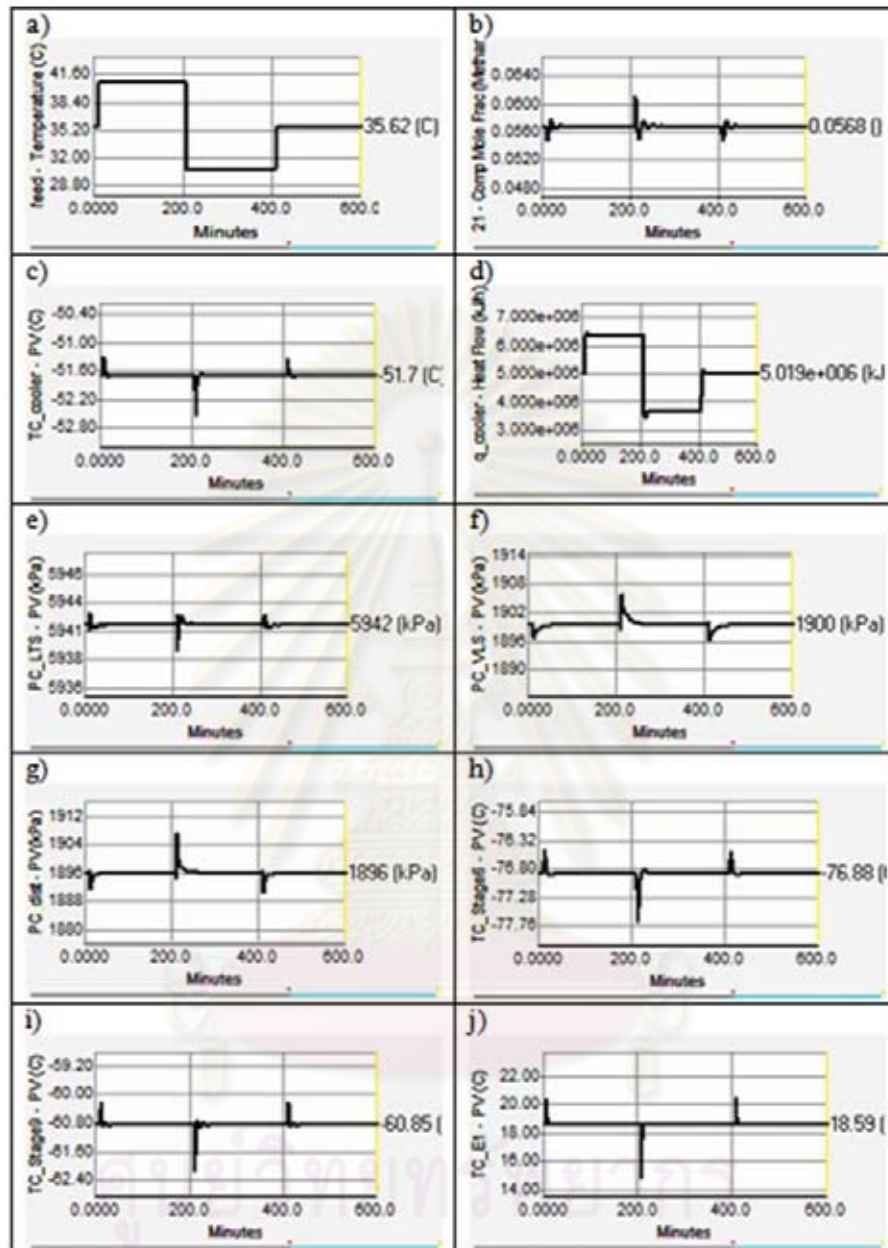

Figure 5.53: Dynamic responses of the natural gas expander plant (Alt4) to a change in the natural gas feed temperature: CS₂, where: (a) the variation natural gas feed temperature, (b) the methane impurity of product, (c) the LTS inlet temperature, (d) the cooler duty, (e) the LTS vessel pressure, (f) the VLS vessel pressure, (g) the DT top stage pressure, (h) the 6th stage temperature of DT, (i) the 9th stage temperature of DT, (j) the cold outlet temperature of exchanger E1

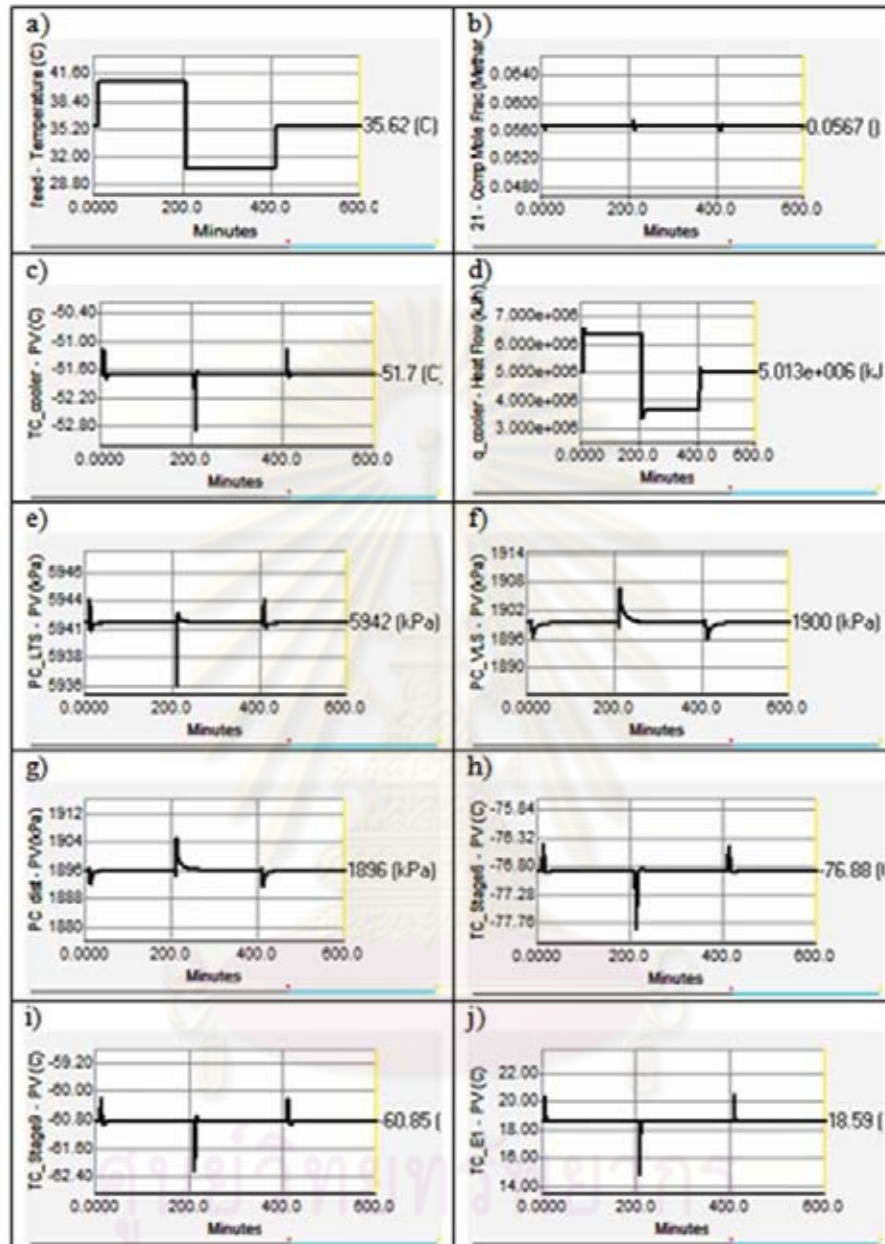

Figure 5.54: Dynamic responses of the natural gas expander plant (Alt4) to a change in the natural gas feed temperature: CS3, where: (a) the variation natural gas feed temperature, (b) the methane impurity of product, (c) the LTS inlet temperature, (d) the cooler duty, (e) the LTS vessel pressure, (f) the VLS vessel pressure, (g) the DT top stage pressure, (h) the 6th stage temperature of DT, (i) the 9th stage temperature of DT, (j) the cold outlet temperature of exchanger E1

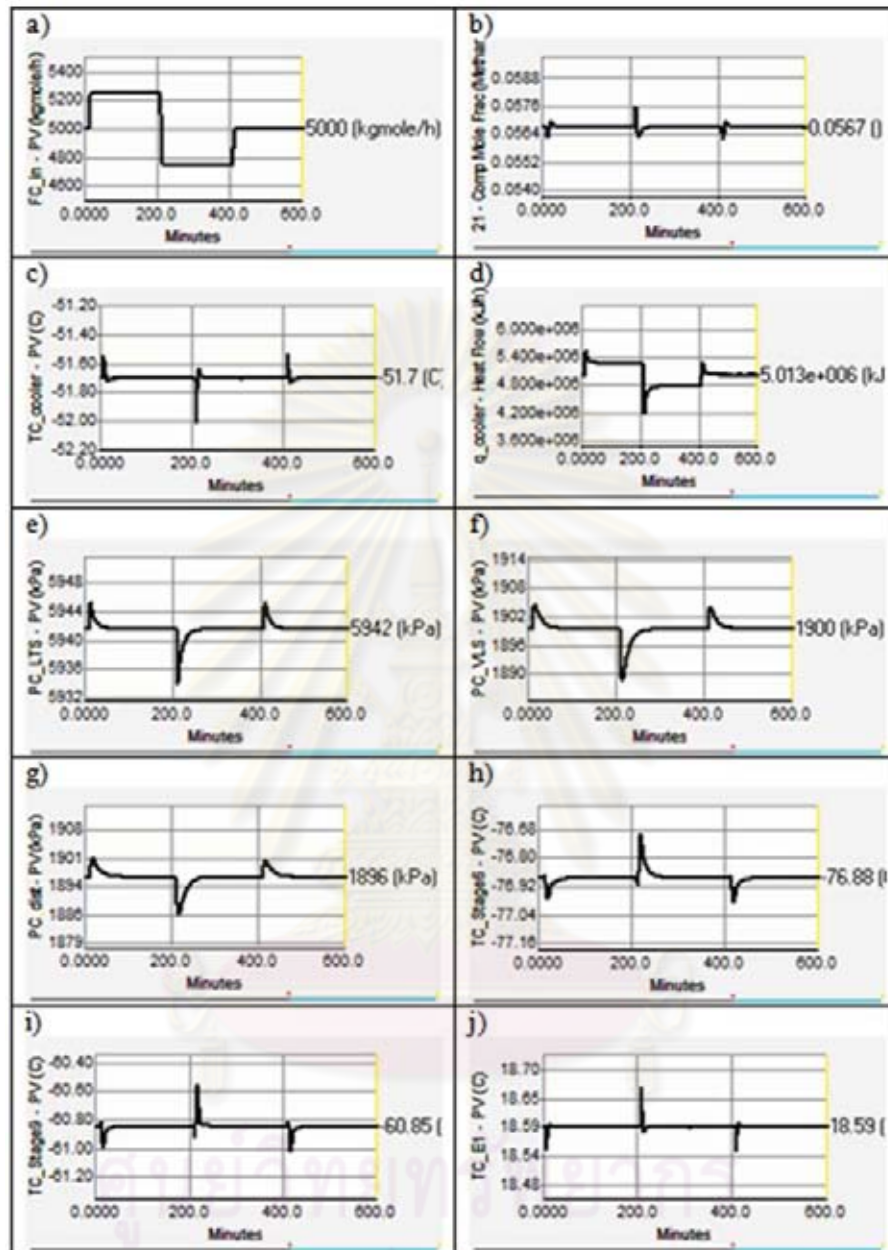

Figure 5.55: Dynamic responses of the natural gas expander plant (Alt4) to a change in the natural gas feed flow rate: CS1, where: (a) the variation natural gas feed flow rate, (b) the methane impurity of product, (c) the LTS inlet temperature, (d) the cooler duty, (e) the LTS vessel pressure, (f) the VLS vessel pressure, (g) the DT top stage pressure, (h) the 6th stage temperature of DT, (i) the 9th stage temperature of DT, (j) the cold outlet temperature of exchanger E1

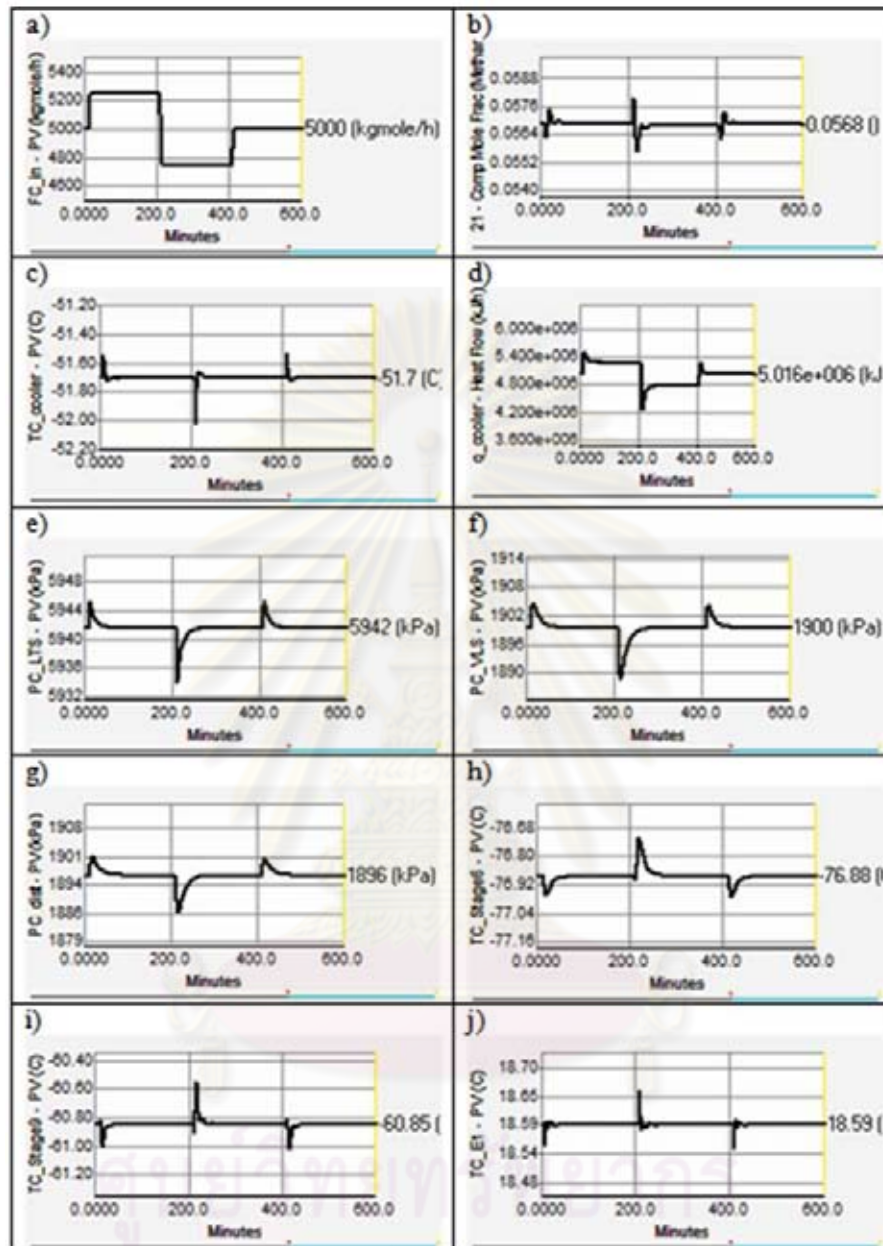

Figure 5.56: Dynamic responses of the natural gas expander plant (Alt4) to a change in the natural gas feed flow rate: CS2, where: (a) the variation natural gas feed flow rate, (b) the methane impurity of product, (c) the LTS inlet temperature, (d) the cooler duty, (e) the LTS vessel pressure, (f) the VLS vessel pressure, (g) the DT top stage pressure, (h) the 6th stage temperature of DT, (i) the 9th stage temperature of DT, (j) the cold outlet temperature of exchanger E1

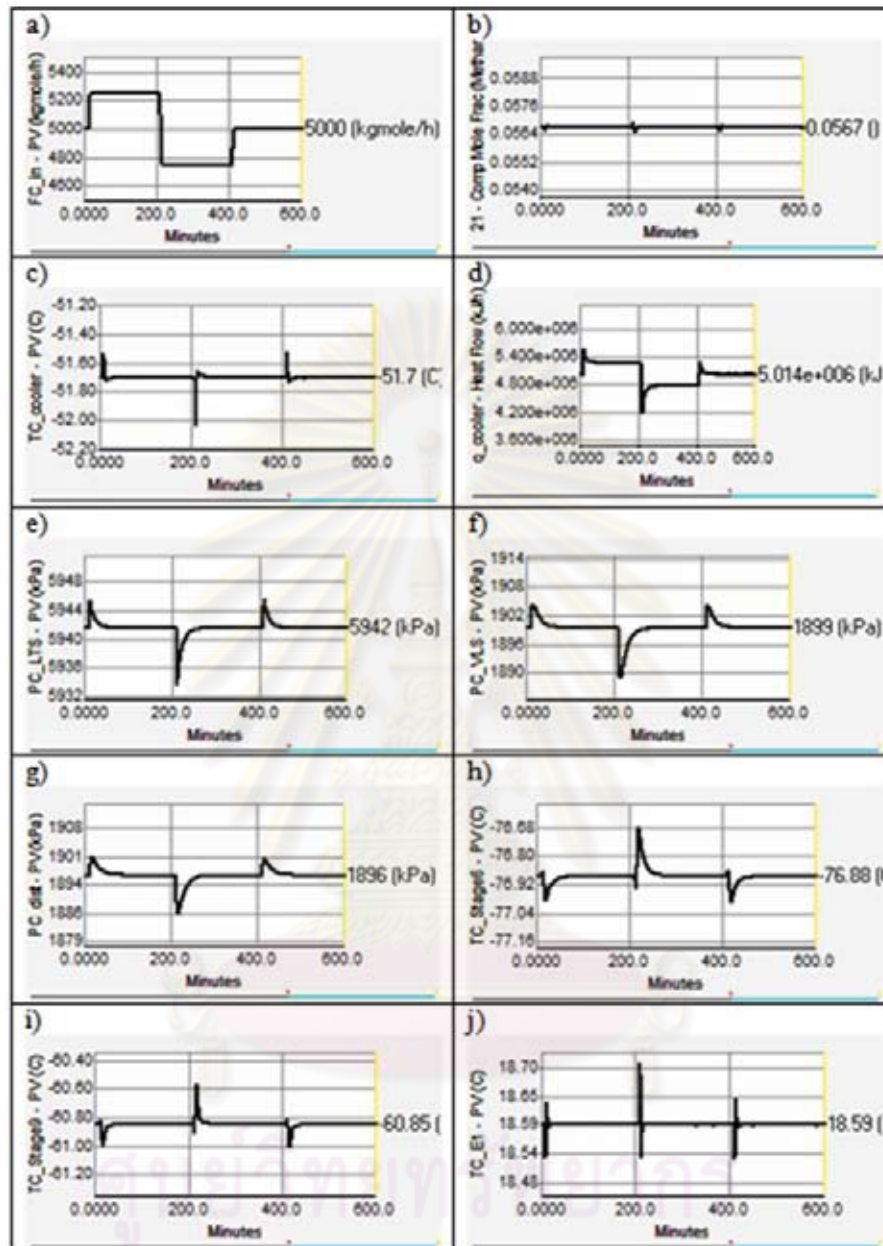

Figure 5.57: Dynamic responses of the natural gas expander plant (Alt4) to a change in the natural gas feed flow rate: CS3, where: (a) the variation natural gas feed flow rate, (b) the methane impurity of product, (c) the LTS inlet temperature, (d) the cooler duty, (e) the LTS vessel pressure, (f) the VLS vessel pressure, (g) the DT top stage pressure, (h) the 6th stage temperature of DT, (i) the 9th stage temperature of DT, (j) the cold outlet temperature of exchanger E1

5.3.6 Dynamic Simulation Results for the TEP Alternative 5

Three disturbance loads are used to evaluate the dynamic performance of the control structures (CS1, CS2 and CS3) for the TEP alternative 5.

Change in the natural gas feed temperature

Figure 5.58, 5.59 and 5.60 show the dynamic responses of the control systems of the TEP alternative 5 to a change in the natural gas feed temperature. In order to make this disturbance, first the natural gas feed temperature is increased from 35.62 °C to 40.62 °C at time equals 10 minutes, and the temperature is decreased from 40.62 °C to 30.62 °C at time equals 210 minutes, then its temperature is returned to its nominal value of 35.62 °C at time equals 410 minutes to 600 minutes (Figure 5.58.a, 5.59.a and 5.60.a).

The three control structures (CS1, CS2 and CS3) give the same result for shifting the thermal disturbance load in natural gas feed stream to cooler as follows. In the first, the hot natural gas inlet temperature is increased and then both the hot LTS inlet temperature and methane-rich residue cold outlet temperature of E1 increase suddenly and return to the set point rapidly because these points are controlled. This disturbance load is shifted to the cooler utility. Therefore, the cooler duty will be increased to a new steady state value in this case for all control structures, shown in Figure 5.58.d, 5.59.d and 5.60.d. For decreasing hot natural gas inlet temperature, the hot LTS inlet and methane-rich residue cold outlet temperature of E1 decrease suddenly and return to the set point rapidly. This disturbance load is shifted to the cooler utility. Therefore, the cooler duty will be decreased to a new steady state value in this case.

As can be seen, this disturbance load has an effect to the impurity of methane in the product. However, the CS2 control structure for this loop is

oscillatory and return to the set point. Therefore, the CS3 control structure can handle this disturbance load more than CS1 and CS2 control structure because this control structure reaches to the set point faster than others. For control of the DT tray temperature, the tray-6 and tray-9 temperature are well controlled. However, the dynamic response of CS3 control structure is smoother than CS1 and CS2 control structure.

Change in the natural gas feed flow rate

Figure 5.61, 5.62 and 5.63 show the dynamic responses of the control systems of the TEP alternative 5 to a change in the natural gas feed temperature. In order to make this disturbance, first the natural gas feed temperature is increased from 5000 kmole/hr to 5250 kmole/hr at time equals 10 minutes, and the temperature is decreased from 5250 kmole/hr to 4750 kmole/hr at time equals 210 minutes, then its temperature is returned to its nominal value of 5000 kmole/hr at time equals 410 minutes to 600 minutes (Figure 5.61.a, 5.62.a and 5.63.a).

The dynamic result can be seen that when the hot natural gas flow rate increases, the cooler duty (Q-83) increases to maintain the LTS inlet temperature, and when the hot flow rate decreases, the cooler duty (Q-83) decreases as well. For the LTS inlet temperature, CS2 control structure is more oscillatory than CS1 and CS3 control structure.

As can be seen, this disturbance has a little bit effect to impurity of methane in the ethane product for all control structures (CS1, CS2 and CS3). The CS2 control structure for this loop has oscillation and reaches to the set point lower than CS1 and CS3 control structure. Therefore, the CS3 control structure can handle this disturbance load more than CS1 and CS2 control structure.

5.3.7 Dynamic Simulation Results for the TEP Alternative 6

Three disturbance loads are used to evaluate the dynamic performance of the control structures (CS1, CS2 and CS3) for the TEP alternative 6.

Change in the natural gas feed temperature

Figure 5.64, 5.65 and 5.66 show the dynamic responses of the control systems of the TEP alternative 6 to a change in the natural gas feed temperature. In order to make this disturbance, first the natural gas feed temperature is increased from 35.62 °C to 40.62 °C at time equals 10 minutes, and the temperature is decreased from 40.62 °C to 30.62 °C at time equals 210 minutes, then its temperature is returned to its nominal value of 35.62 °C at time equals 410 minutes to 600 minutes (Figure 5.64.a, 5.65.a and 5.66.a).

The three control structures (CS1, CS2 and CS3) give the same result for shifting the thermal disturbance load in natural gas feed stream to cooler as follows. The dynamic responses of alternative 6 are similar to those of alternative 5 for all loops in the process but all control structures of alternative 6 have the response worse than alternative 5.

As can be seen, this disturbance load has an effect to the impurity of methane in the product for this alternative like the alternative 5. Therefore, the responses of composition and tray temperature loop in this alternative are similar to those in alternative 5.

Change in the natural gas feed flow rate

Figure 5.67, 5.68 and 5.69 show the dynamic responses of the control systems of the TEP alternative 6 to a change in the natural gas feed temperature. In order to make this disturbance, first the natural gas feed temperature is increased

from 5000 kmole/hr to 5250 kmole/hr at time equals 10 minutes, and the temperature is decreased from 5250 kmole/hr to 4750 kmole/hr at time equals 210 minutes, then its temperature is returned to its nominal value of 5000 kmole/hr at time equals 410 minutes to 600 minutes (Figure 5.67.a, 5.68.a and 5.69.a). As can be seen, this temperature response is very fast, the new steady state is reached rapidly.

As can be seen, the responses of this alternative are similar to those of alternative 5 for all control structures (CS1, CS2 and CS3) in each loop. However, the CS3 control structure has the responses better than CS1 and CS2 control structure like the alternative 5 but worse than alternative 5 a little. For the tray temperatures in the DT, the responses are slightly well controlled but CS2 is more oscillation than CS1 and CS3. However, the dynamic response of CS3 control structure is smoother than CS1 and CS2 control structure.



ศูนย์วิทยทรัพยากร
จุฬาลงกรณ์มหาวิทยาลัย

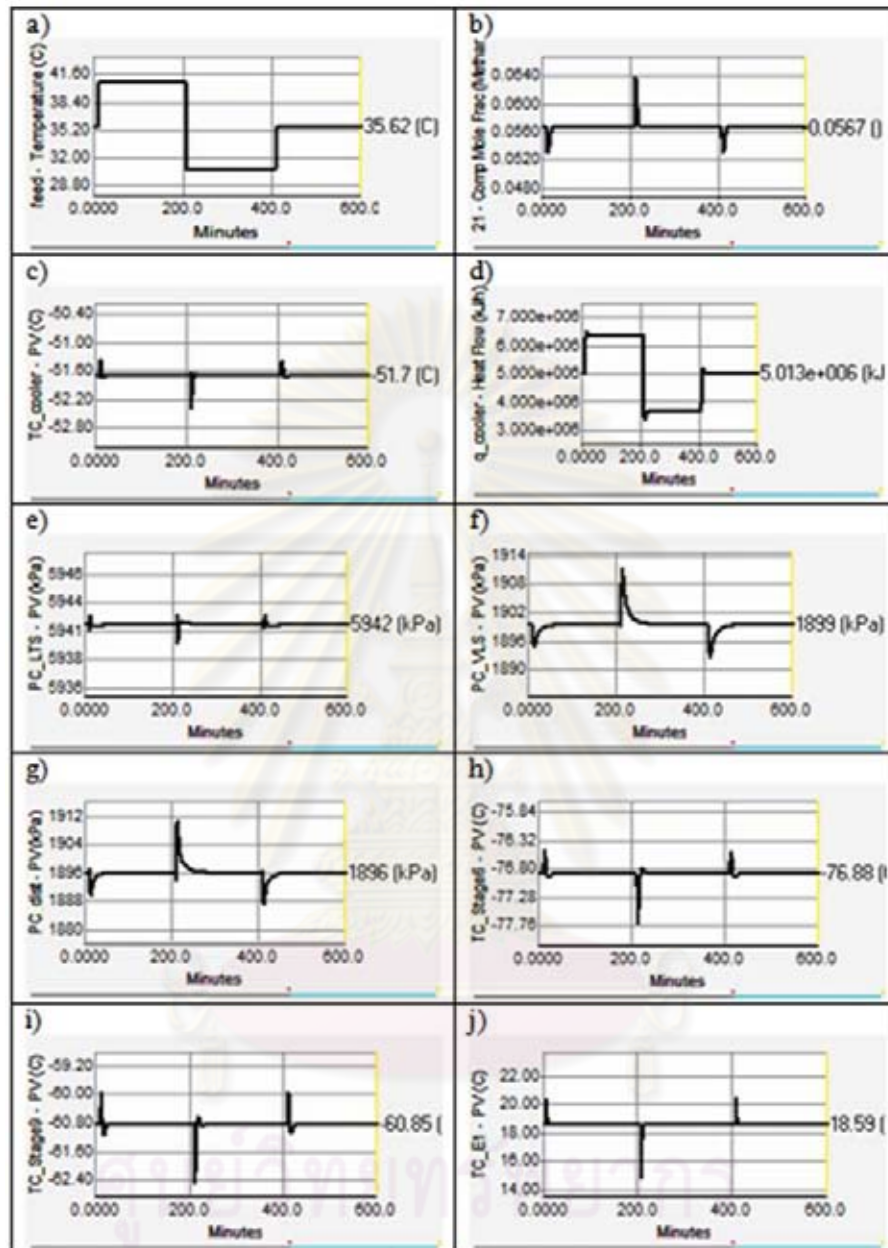

Figure 5.58: Dynamic responses of the natural gas expander plant (Alt5) to a change in the natural gas feed temperature: CS1, where: (a) the variation natural gas feed temperature, (b) the methane impurity of product, (c) the LTS inlet temperature, (d) the cooler duty, (e) the LTS vessel pressure, (f) the VLS vessel pressure, (g) the DT top stage pressure, (h) the 6th stage temperature of DT, (i) the 9th stage temperature of DT, (j) the cold outlet temperature of exchanger E1

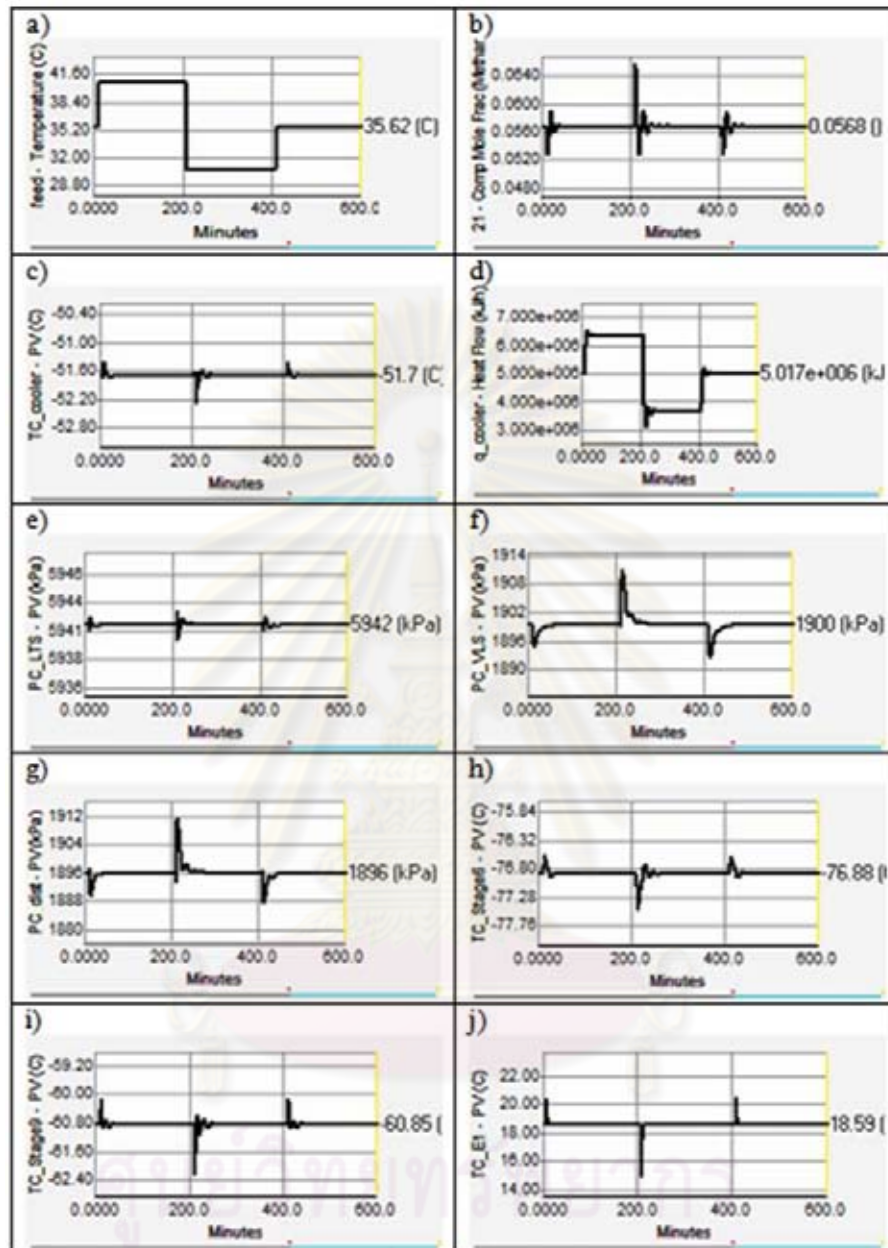

Figure 5.59: Dynamic responses of the natural gas expander plant (Alt5) to a change in the natural gas feed temperature: CS₂, where: (a) the variation natural gas feed temperature, (b) the methane impurity of product, (c) the LTS inlet temperature, (d) the cooler duty, (e) the LTS vessel pressure, (f) the VLS vessel pressure, (g) the DT top stage pressure, (h) the 6th stage temperature of DT, (i) the 9th stage temperature of DT, (j) the cold outlet temperature of exchanger E1

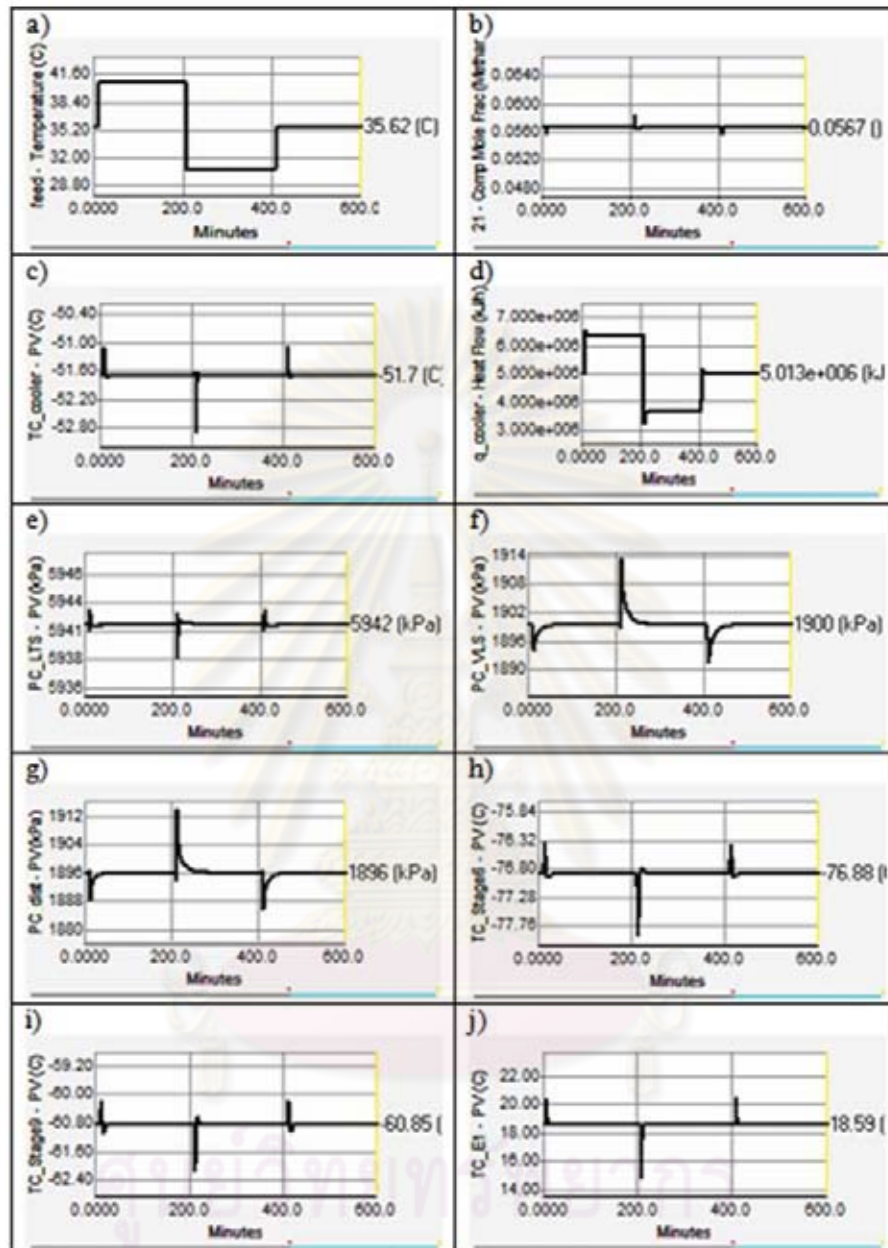

Figure 5.60: Dynamic responses of the natural gas expander plant (Alt5) to a change in the natural gas feed temperature: CS3, where: (a) the variation natural gas feed temperature, (b) the methane impurity of product, (c) the LTS inlet temperature, (d) the cooler duty, (e) the LTS vessel pressure, (f) the VLS vessel pressure, (g) the DT top stage pressure, (h) the 6th stage temperature of DT, (i) the 9th stage temperature of DT, (j) the cold outlet temperature of exchanger E1

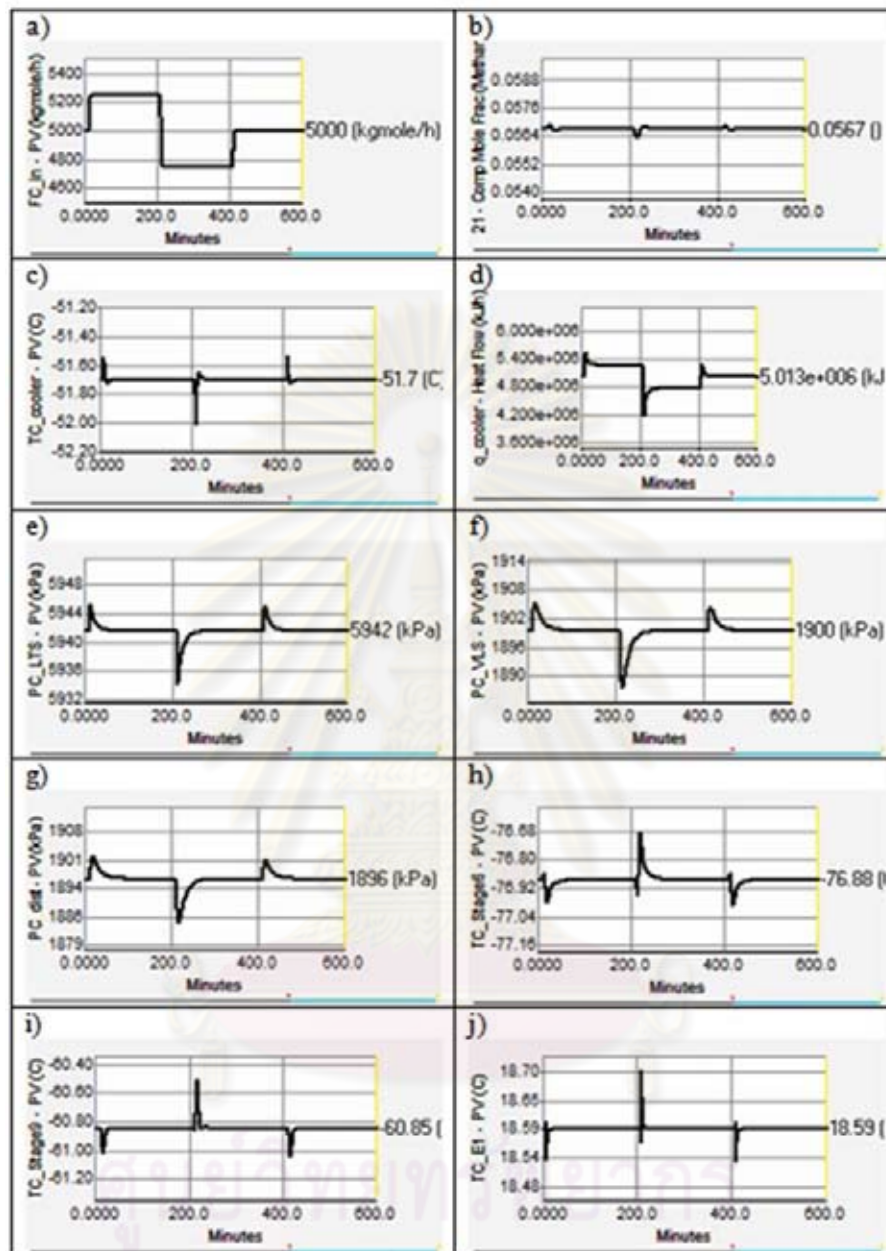

Figure 5.61: Dynamic responses of the natural gas expander plant (Alt5) to a change in the natural gas feed flow rate: CS1, where: (a) the variation natural gas feed flow rate, (b) the methane impurity of product, (c) the LTS inlet temperature, (d) the cooler duty, (e) the LTS vessel pressure, (f) the VLS vessel pressure, (g) the DT top stage pressure, (h) the 6th stage temperature of DT, (i) the 9th stage temperature of DT, (j) the cold outlet temperature of exchanger E1

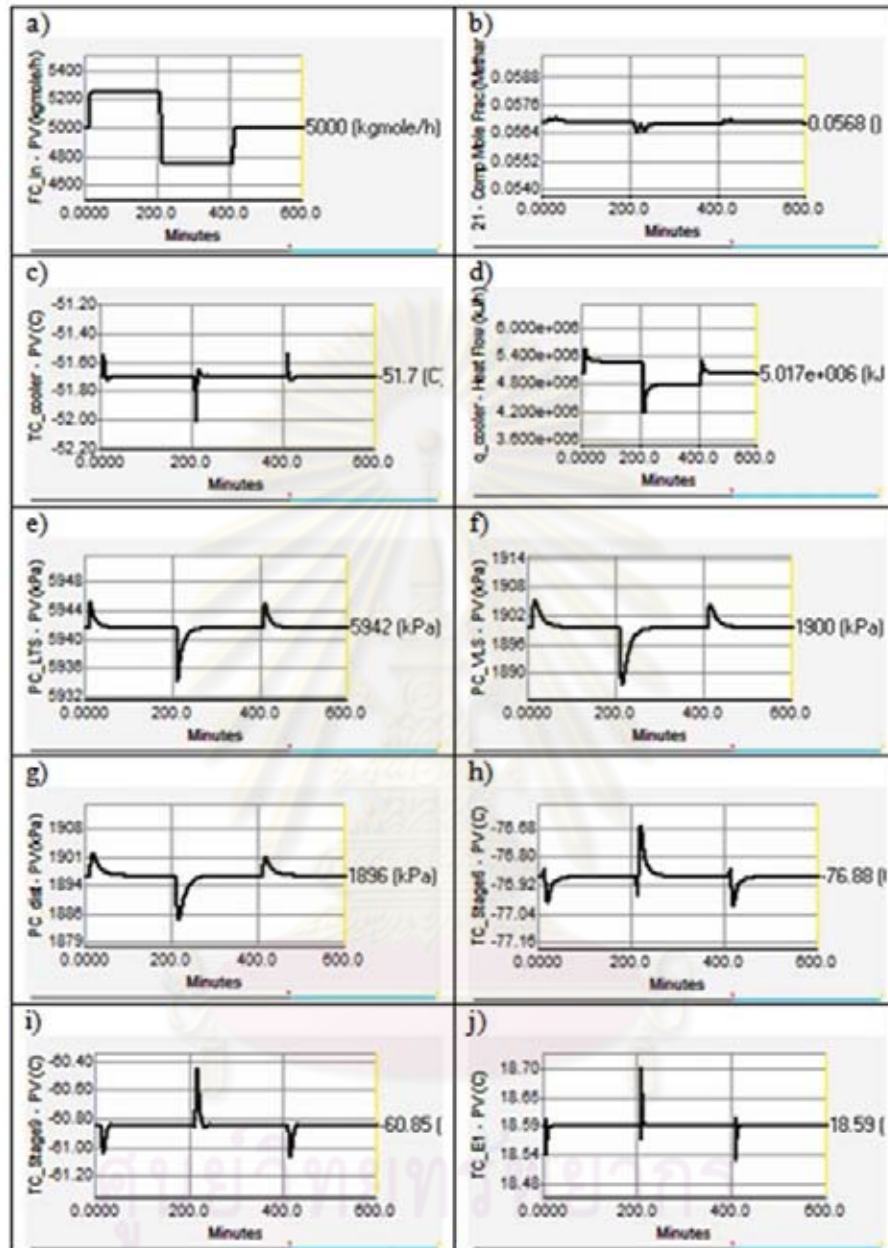

Figure 5.62: Dynamic responses of the natural gas expander plant (Alt5) to a change in the natural gas feed flow rate: CS₂, where: (a) the variation natural gas feed flow rate, (b) the methane impurity of product, (c) the LTS inlet temperature, (d) the cooler duty, (e) the LTS vessel pressure, (f) the VLS vessel pressure, (g) the DT top stage pressure, (h) the 6th stage temperature of DT, (i) the 9th stage temperature of DT, (j) the cold outlet temperature of exchanger E1

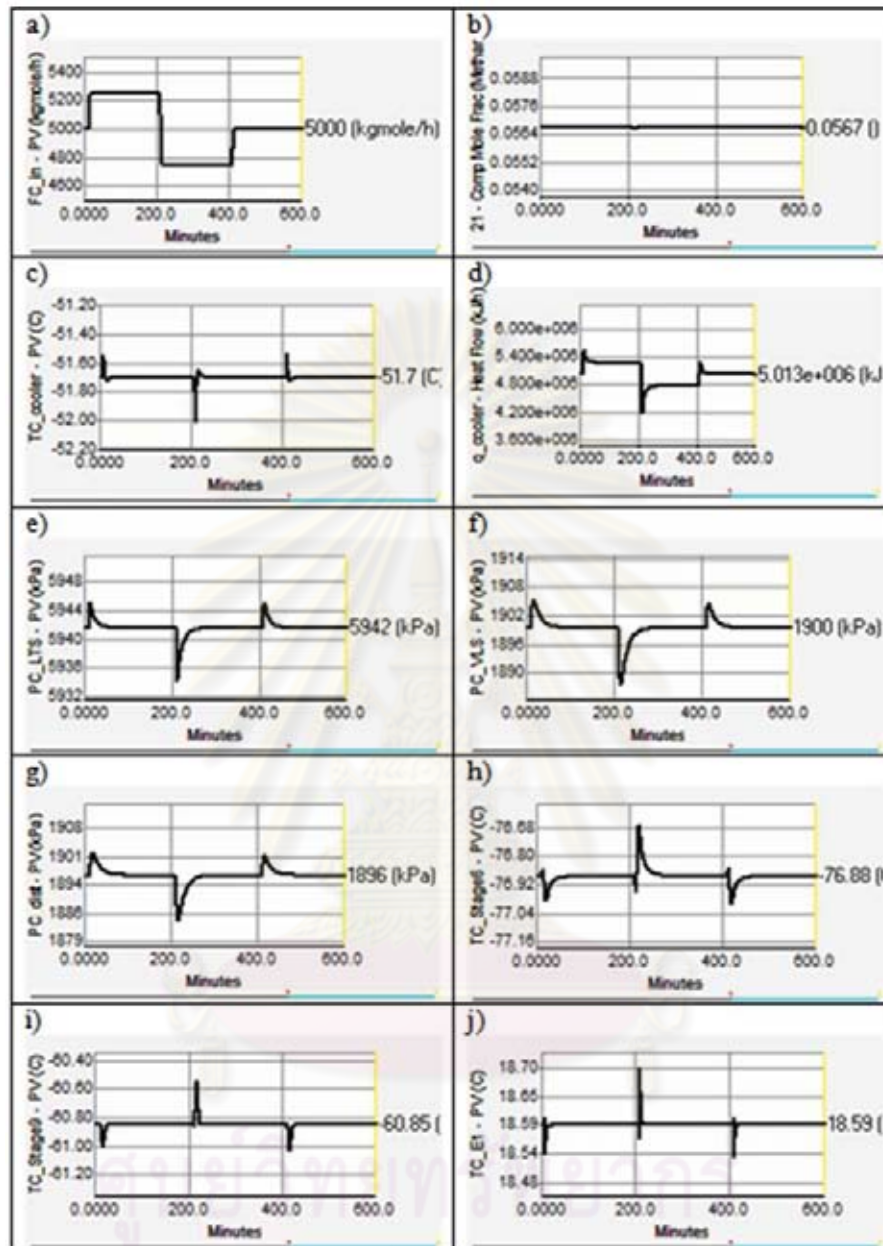

Figure 5.63: Dynamic responses of the natural gas expander plant (Alt5) to a change in the natural gas feed flow rate: CS3, where: (a) the variation natural gas feed flow rate, (b) the methane impurity of product, (c) the LTS inlet temperature, (d) the cooler duty, (e) the LTS vessel pressure, (f) the VLS vessel pressure, (g) the DT top stage pressure, (h) the 6th stage temperature of DT, (i) the 9th stage temperature of DT, (j) the cold outlet temperature of exchanger E1

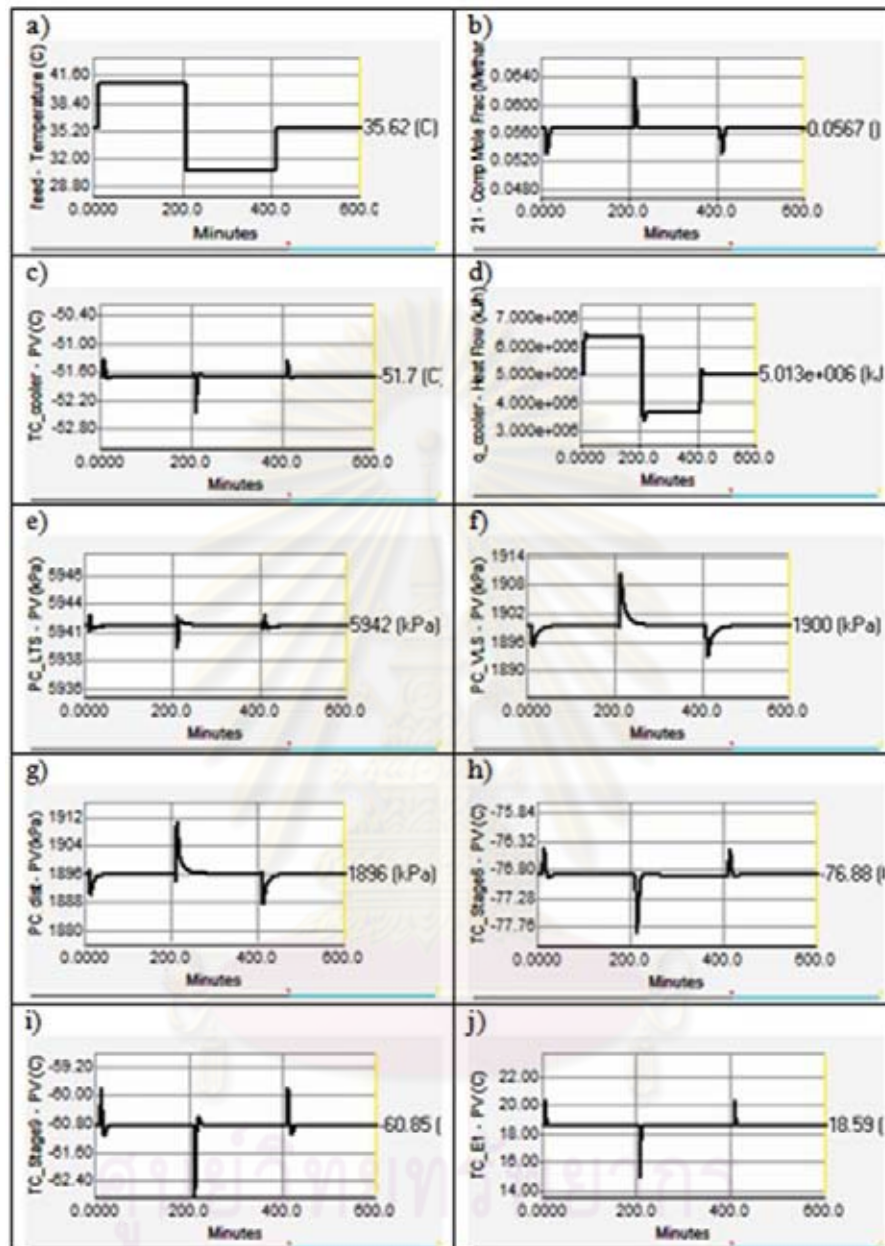

Figure 5.64: Dynamic responses of the natural gas expander plant (Alt6) to a change in the natural gas feed temperature: CS1, where: (a) the variation natural gas feed temperature, (b) the methane impurity of product, (c) the LTS inlet temperature, (d) the cooler duty, (e) the LTS vessel pressure, (f) the VLS vessel pressure, (g) the DT top stage pressure, (h) the 6th stage temperature of DT, (i) the 9th stage temperature of DT, (j) the cold outlet temperature of exchanger E1

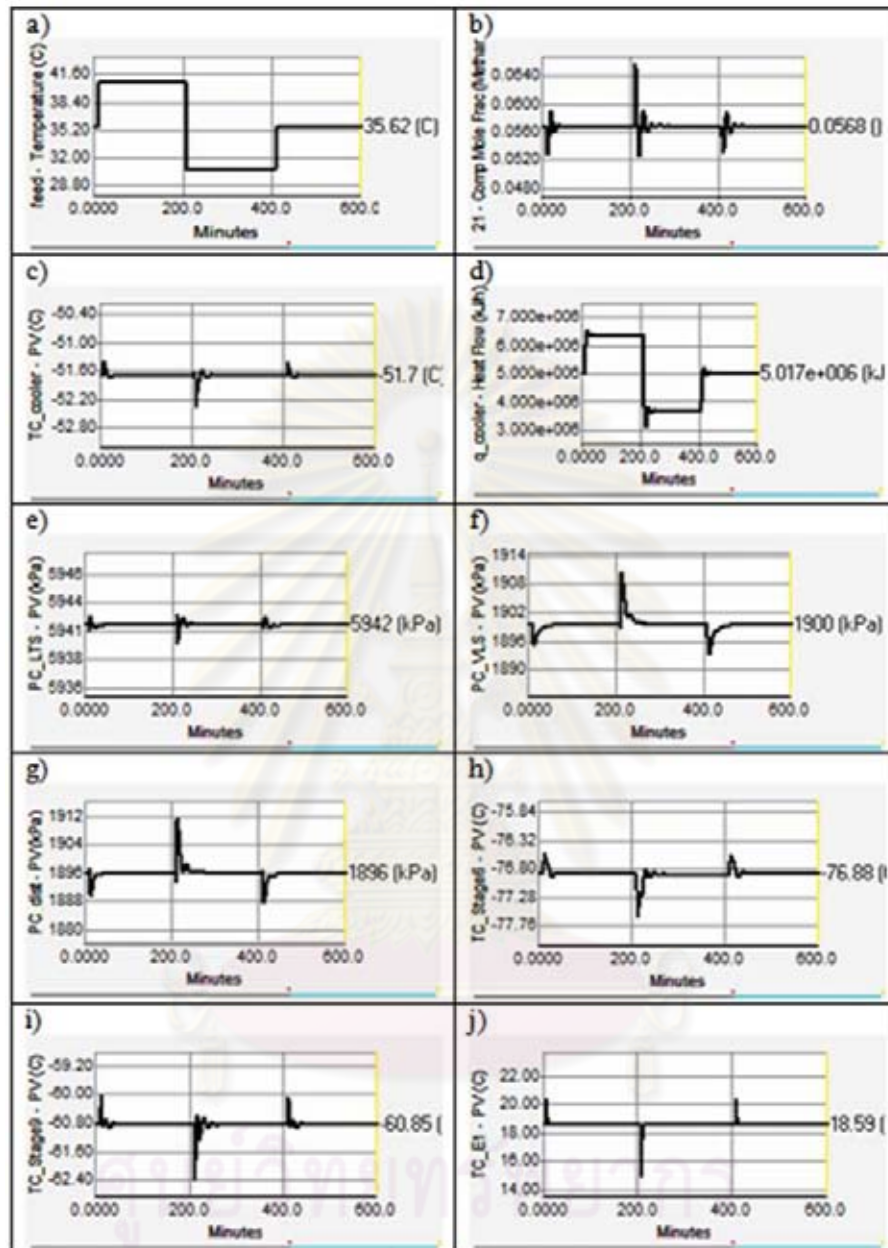

Figure 5.65: Dynamic responses of the natural gas expander plant (Alt6) to a change in the natural gas feed temperature: CS₂, where: (a) the variation natural gas feed temperature, (b) the methane impurity of product, (c) the LTS inlet temperature, (d) the cooler duty, (e) the LTS vessel pressure, (f) the VLS vessel pressure, (g) the DT top stage pressure, (h) the 6th stage temperature of DT, (i) the 9th stage temperature of DT, (j) the cold outlet temperature of exchanger E1

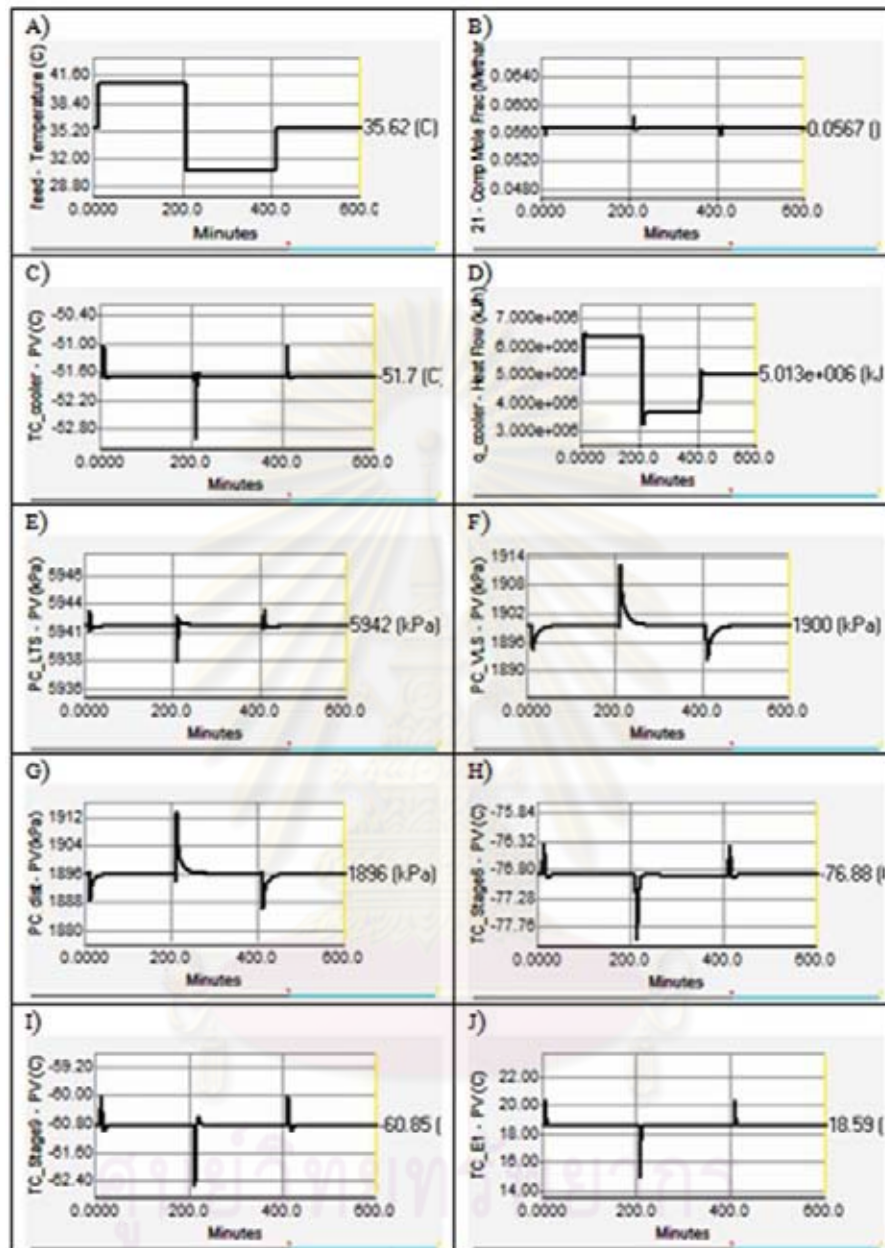

Figure 5.66: Dynamic responses of the natural gas expander plant (Alt6) to a change in the natural gas feed temperature: CS3, where: (a) the variation natural gas feed temperature, (b) the methane impurity of product, (c) the LTS inlet temperature, (d) the cooler duty, (e) the LTS vessel pressure, (f) the VLS vessel pressure, (g) the DT top stage pressure, (h) the 6th stage temperature of DT, (i) the 9th stage temperature of DT, (j) the cold outlet temperature of exchanger E1

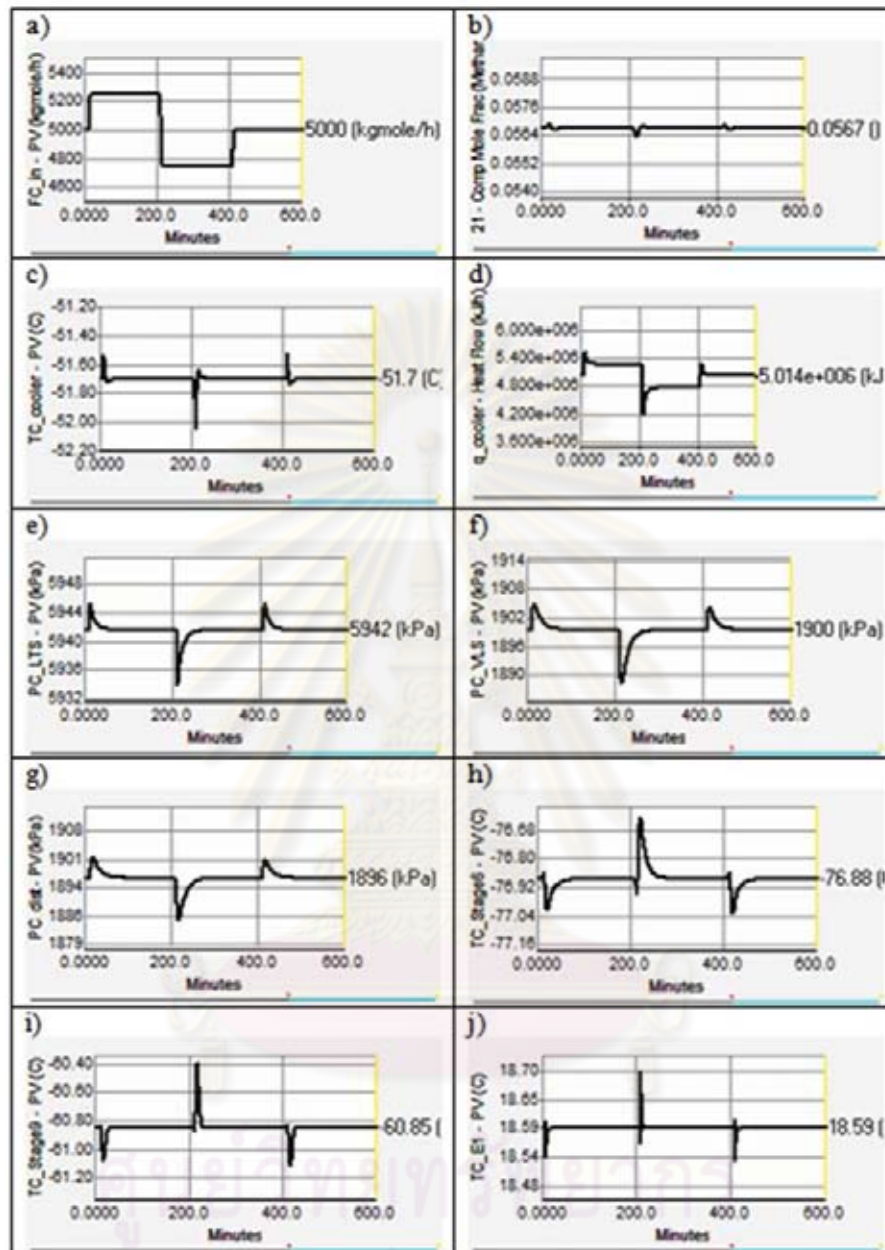

Figure 5.67: Dynamic responses of the natural gas expander plant (Alt6) to a change in the natural gas feed flow rate: CS1, where: (a) the variation natural gas feed flow rate, (b) the methane impurity of product, (c) the LTS inlet temperature, (d) the cooler duty, (e) the LTS vessel pressure, (f) the VLS vessel pressure, (g) the DT top stage pressure, (h) the 6th stage temperature of DT, (i) the 9th stage temperature of DT, (j) the cold outlet temperature of exchanger E1

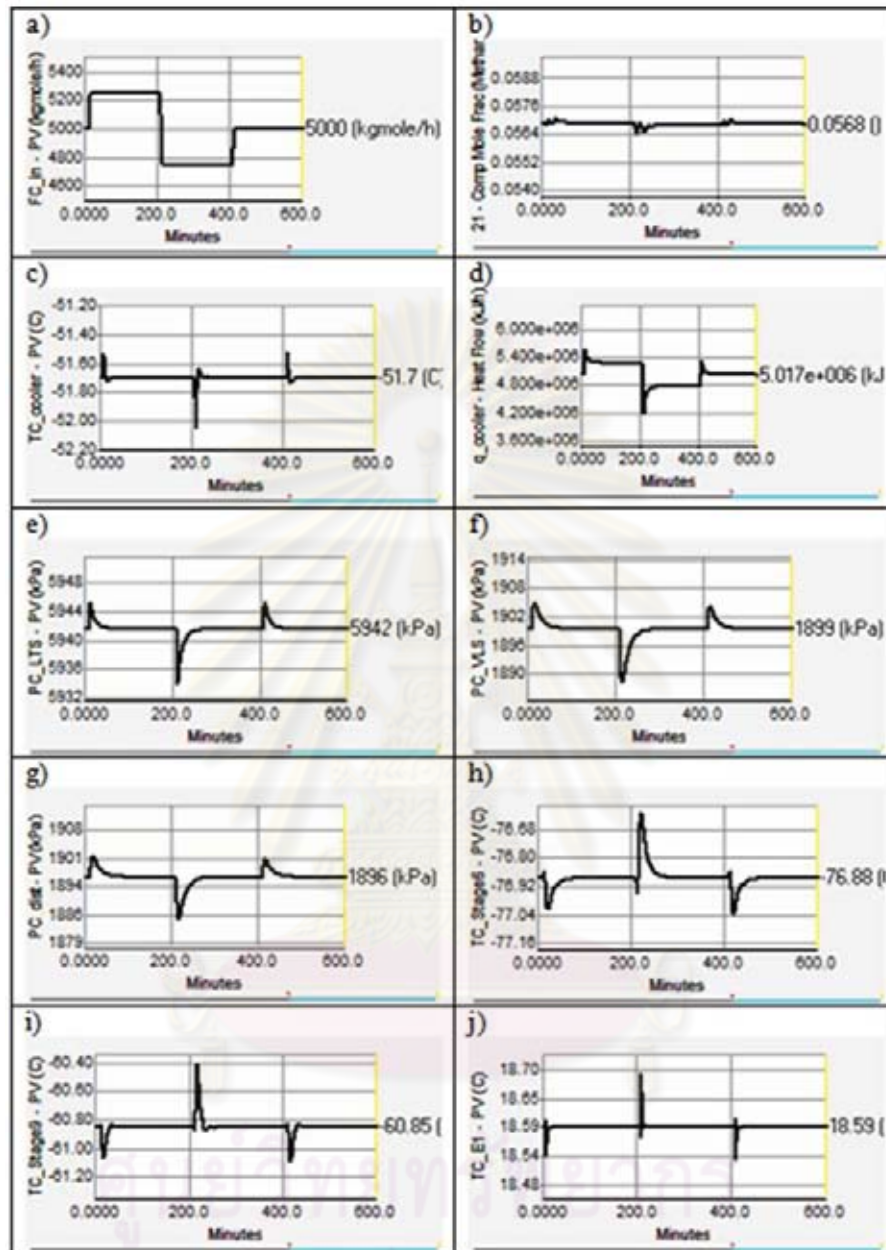

Figure 5.68: Dynamic responses of the natural gas expander plant (Alt6) to a change in the natural gas feed flow rate: CS₂, where: (a) the variation natural gas feed flow rate, (b) the methane impurity of product, (c) the LTS inlet temperature, (d) the cooler duty, (e) the LTS vessel pressure, (f) the VLS vessel pressure, (g) the DT top stage pressure, (h) the 6th stage temperature of DT, (i) the 9th stage temperature of DT, (j) the cold outlet temperature of exchanger E1

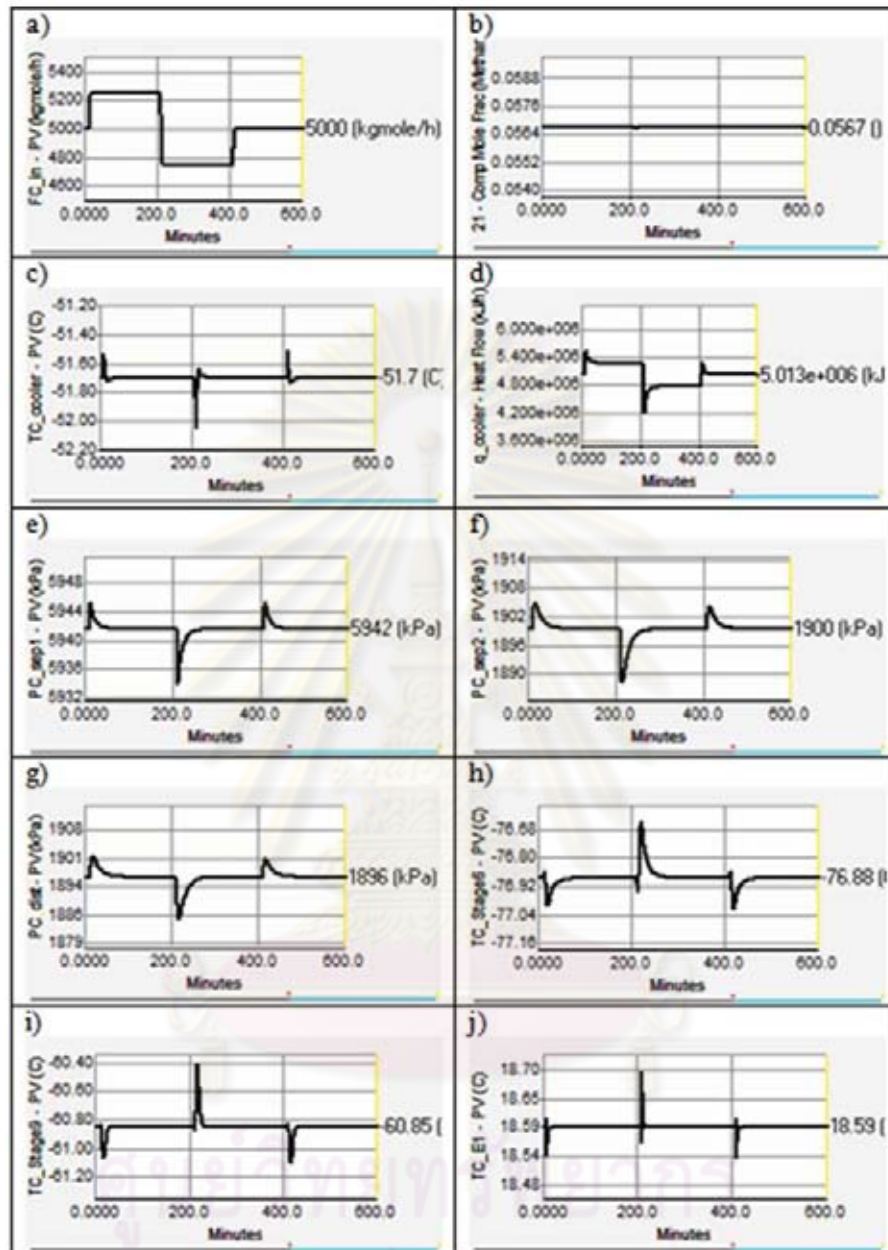

Figure 5.69: Dynamic responses of the natural gas expander plant (Alt6) to a change in the natural gas feed flow rate: CS3, where: (a) the variation natural gas feed flow rate, (b) the methane impurity of product, (c) the LTS inlet temperature, (d) the cooler duty, (e) the LTS vessel pressure, (f) the VLS vessel pressure, (g) the DT top stage pressure, (h) the 6th stage temperature of DT, (i) the 9th stage temperature of DT, (j) the cold outlet temperature of exchanger E1

5.3.8 Dynamic Simulation Results for the TEP Alternative 7

Three disturbance loads are used to evaluate the dynamic performance of the control structures (CS1, CS2 and CS3) for the TEP alternative 7.

Change in the natural gas feed temperature

Figure 5.70, 5.71 and 5.72 show the dynamic responses of the control systems of the TEP alternative 7 to a change in the natural gas feed temperature. In order to make this disturbance, first the natural gas feed temperature is increased from $35.62\text{ }^{\circ}\text{C}$ to $40.62\text{ }^{\circ}\text{C}$ at time equals 10 minutes, and the temperature is decreased from $40.62\text{ }^{\circ}\text{C}$ to $30.62\text{ }^{\circ}\text{C}$ at time equals 210 minutes, then its temperature is returned to its nominal value of $35.62\text{ }^{\circ}\text{C}$ at time equals 410 minutes to 600 minutes (Figure 5.70.a, 5.71.a and 5.72.a).

The three control structures (CS1, CS2 and CS3) give the same result for shifting the thermal disturbance load in natural gas feed stream to cooler as follows. In the first, the hot natural gas inlet temperature is increased and then both the hot LTS inlet temperature and methane-rich residue cold outlet temperature of E1 increase suddenly and return to the set point rapidly. This disturbance load is shifted to the cooler utility. Therefore, the cooler duty will be increased to a new steady state value in this case for all control structures, shown in Figure 5.70.d, 5.71.d and 5.72.d. When the hot natural gas inlet temperature is decreased, this disturbance load is shifted to the cooler utility. Therefore, the cooler duty will be decreased to a new steady state value in this case.

As can be seen, this disturbance load has an effect to the impurity of methane in the product. However, the CS2 control structure for this loop is oscillatory and return to the set point. However, the CS3 control structure can handle this disturbance load more than CS1 and CS2 control structure because this

control structure reaches to the set point faster than and has overshoot less than others. For control of the DT tray temperature, the tray-6 and tray-9 temperature are well controlled. However, the dynamic response of CS3 control structure is smoother than CS1 and CS2 control structure.

Change in the natural gas feed flow rate

Figure 5.73, 5.74 and 5.75 show the dynamic responses of the control systems of the TEP alternative 7 to a change in the natural gas feed temperature. In order to make this disturbance, first the natural gas feed temperature is increased from 5000 kmole/hr to 5250 kmole/hr at time equals 10 minutes, and the temperature is decreased from 5250 kmole/hr to 4750 kmole/hr at time equals 210 minutes, then its temperature is returned to its nominal value of 5000 kmole/hr at time equals 410 minutes to 600 minutes (Figure 5.73.a, 5.74.a and 5.75.a).

The dynamic result can be seen that when the hot natural gas flow rate increases, the cooler duty (Q-83) increases to maintain the LTS inlet temperature, and when the hot flow rate decreases, the cooler duty (Q-83) decreases as well. For responses of the LTS inlet temperature control, CS2 control structure is more oscillatory than CS1 and CS3 control structure.

As can be seen, this disturbance has a little effect to impurity of methane in the ethane product for all control structures (CS1, CS2 and CS3). The CS2 control structure for this loop has oscillation and reaches to the set point lower than CS1 and CS3 control structure. Therefore, the CS3 control structure can handle this disturbance load more than CS1 and CS2 control structure.

5.3.9 Dynamic Simulation Results for the TEP Alternative 8

Three disturbance loads are used to evaluate the dynamic performance of the control structures (CS1, CS2 and CS3) for the TEP alternative 8.

Change in the natural gas feed temperature

Figure 5.76, 5.77 and 5.78 show the dynamic responses of the control systems of the TEP alternative 8 to a change in the natural gas feed temperature. In order to make this disturbance, first the natural gas feed temperature is increased from 35.62 °C to 40.62 °C at time equals 10 minutes, and the temperature is decreased from 40.62 °C to 30.62 °C at time equals 210 minutes, then its temperature is returned to its nominal value of 35.62 °C at time equals 410 minutes to 600 minutes (Figure 5.76.a, 5.77.a and 5.78.a).

The three control structures (CS1, CS2 and CS3) give the same result for shifting the thermal disturbance load in natural gas feed stream to cooler as follows. The dynamic responses of alternative 8 are similar to those of alternative 7 for all loops in the process but all control structures of alternative 8 have the response worse than alternative 7.

As can be seen, this disturbance load has an effect to the impurity of methane in the product for this alternative like the alternative 7. Therefore, the responses of composition and tray temperature loop in this alternative are similar to those in alternative 7.

Change in the natural gas feed flow rate

Figure 5.79, 5.80 and 5.81 show the dynamic responses of the control systems of the TEP alternative 8 to a change in the natural gas feed temperature. In order to make this disturbance, first the natural gas feed temperature is increased

from 5000 kmole/hr to 5250 kmole/hr at time equals 10 minutes, and the temperature is decreased from 5250 kmole/hr to 4750 kmole/hr at time equals 210 minutes, then its temperature is returned to its nominal value of 5000 kmole/hr at time equals 410 minutes to 600 minutes (Figure 5.79.a, 5.80.a and 5.81.a). As can be seen, this temperature response is very fast, the new steady state is reached rapidly.

As can be seen, the responses of this alternative are similar to those of alternative 7 for all control structures (CS1, CS2 and CS3) in each loop. However, the CS3 control structure has the responses better than CS1 and CS2 control structure like the alternative 7 but worse than alternative 7 a little. For the tray temperatures in the DT, the responses are slightly well controlled but CS2 is more oscillation than CS1 and CS3. However, the dynamic response of CS3 control structure is smoother than CS1 and CS2 control structure.



ศูนย์วิทยทรัพยากร
จุฬาลงกรณ์มหาวิทยาลัย

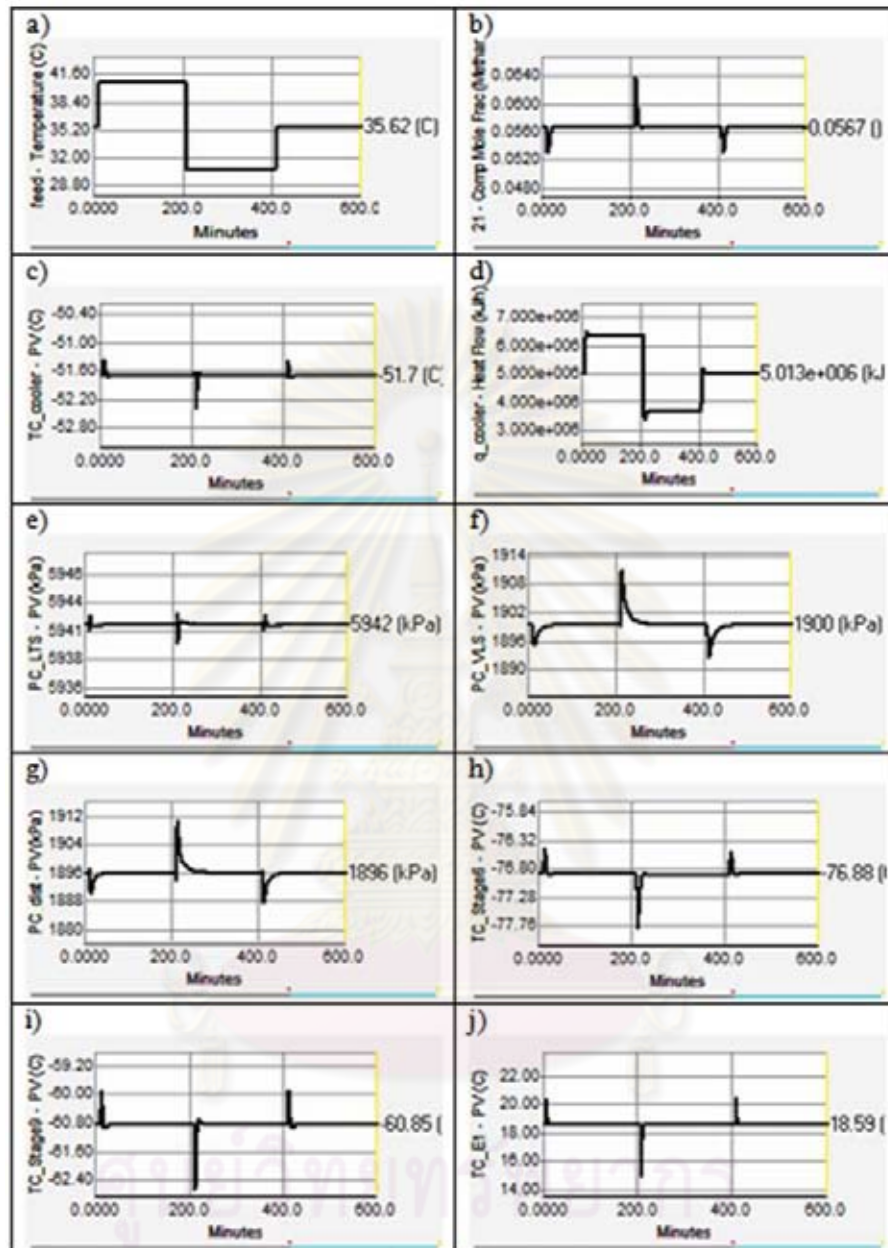

Figure 5.70: Dynamic responses of the natural gas expander plant (Alt7) to a change in the natural gas feed temperature: CS1, where: (a) the variation natural gas feed temperature, (b) the methane impurity of product, (c) the LTS inlet temperature, (d) the cooler duty, (e) the LTS vessel pressure, (f) the VLS vessel pressure, (g) the DT top stage pressure, (h) the 6th stage temperature of DT, (i) the 9th stage temperature of DT, (j) the cold outlet temperature of exchanger E1

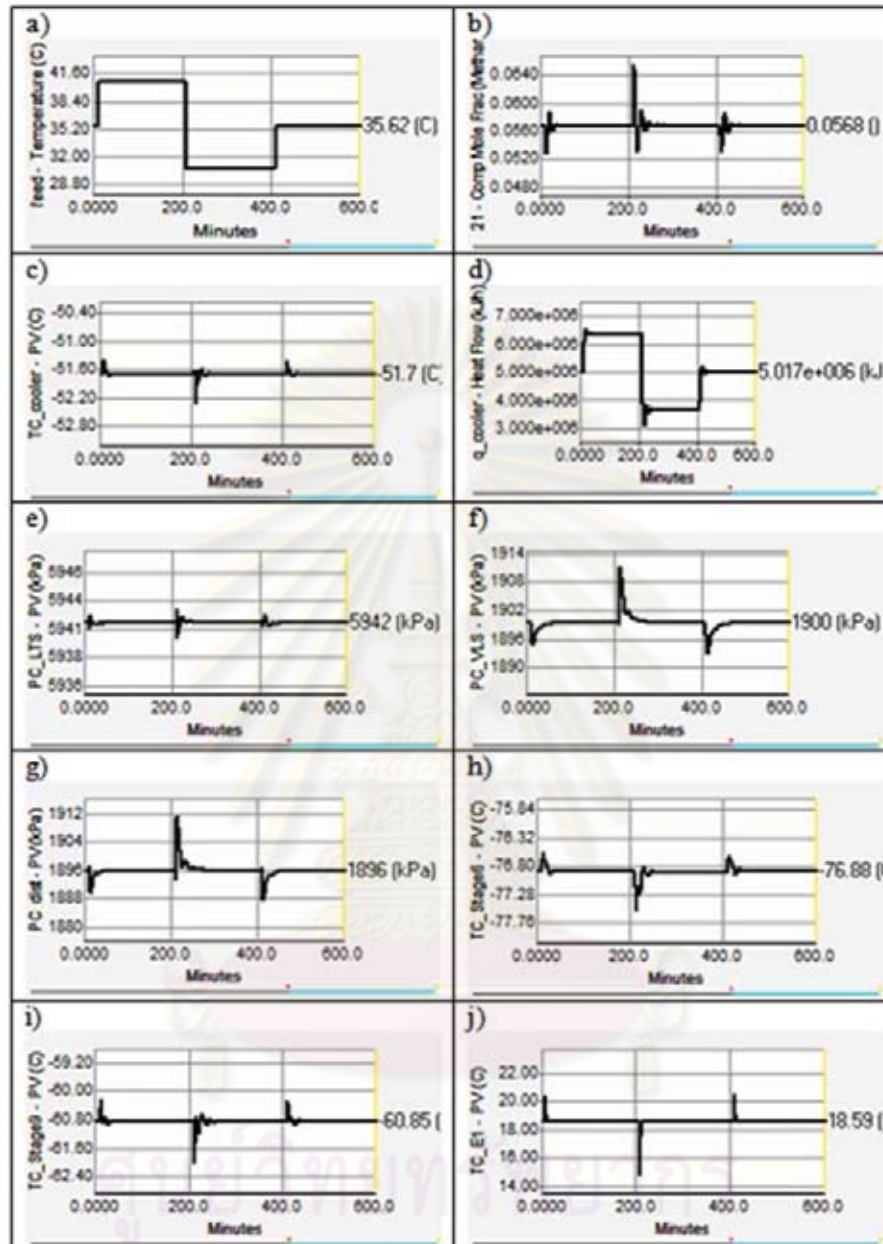

Figure 5.71: Dynamic responses of the natural gas expander plant (Alt7) to a change in the natural gas feed temperature: CS₂, where: (a) the variation natural gas feed temperature, (b) the methane impurity of product, (c) the LTS inlet temperature, (d) the cooler duty, (e) the LTS vessel pressure, (f) the VLS vessel pressure, (g) the DT top stage pressure, (h) the 6th stage temperature of DT, (i) the 9th stage temperature of DT, (j) the cold outlet temperature of exchanger E1

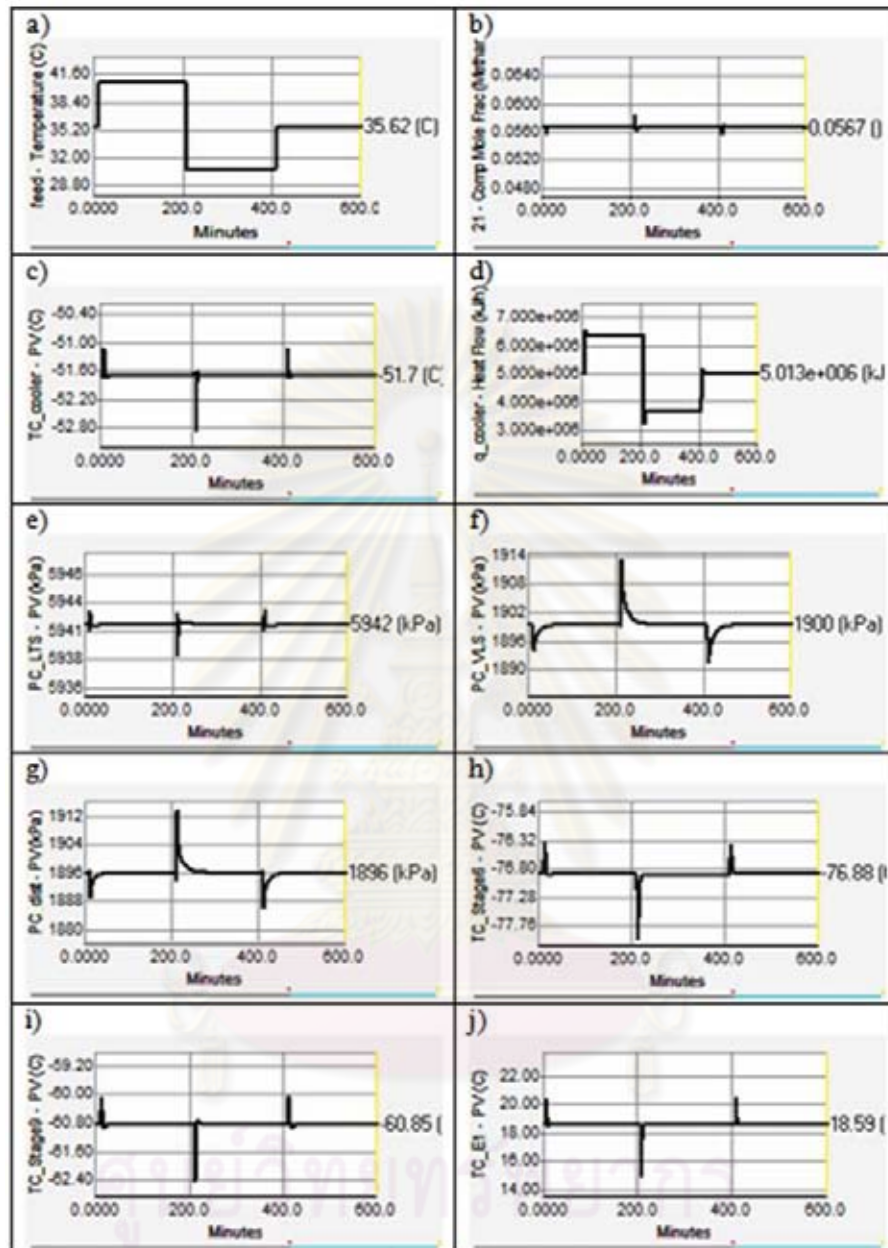

Figure 5.72: Dynamic responses of the natural gas expander plant (Alt7) to a change in the natural gas feed temperature: CS3, where: (a) the variation natural gas feed temperature, (b) the methane impurity of product, (c) the LTS inlet temperature, (d) the cooler duty, (e) the LTS vessel pressure, (f) the VLS vessel pressure, (g) the DT top stage pressure, (h) the 6th stage temperature of DT, (i) the 9th stage temperature of DT, (j) the cold outlet temperature of exchanger E1

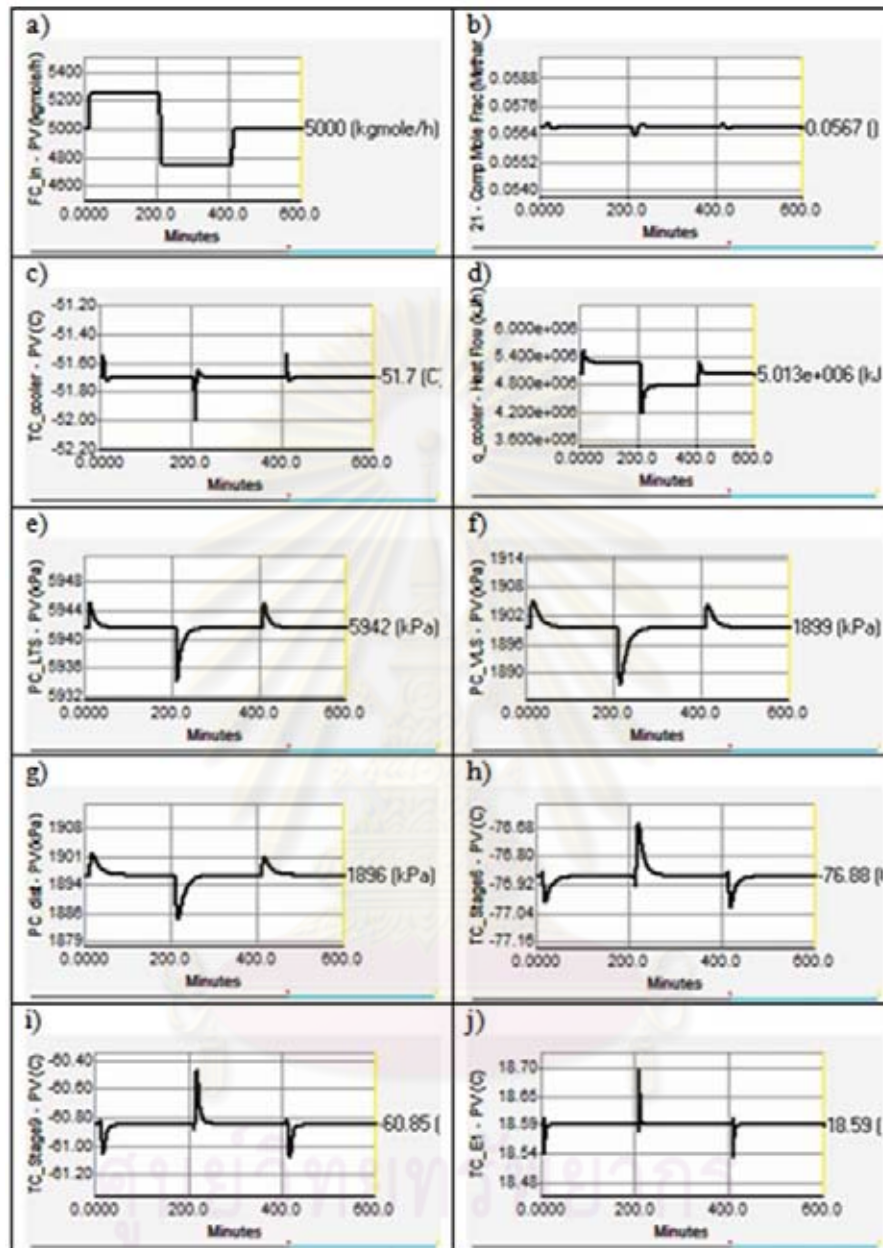

Figure 5.73: Dynamic responses of the natural gas expander plant (Alt7) to a change in the natural gas feed flow rate: CS1, where: (a) the variation natural gas feed flow rate, (b) the methane impurity of product, (c) the LTS inlet temperature, (d) the cooler duty, (e) the LTS vessel pressure, (f) the VLS vessel pressure, (g) the DT top stage pressure, (h) the 6th stage temperature of DT, (i) the 9th stage temperature of DT, (j) the cold outlet temperature of exchanger E1

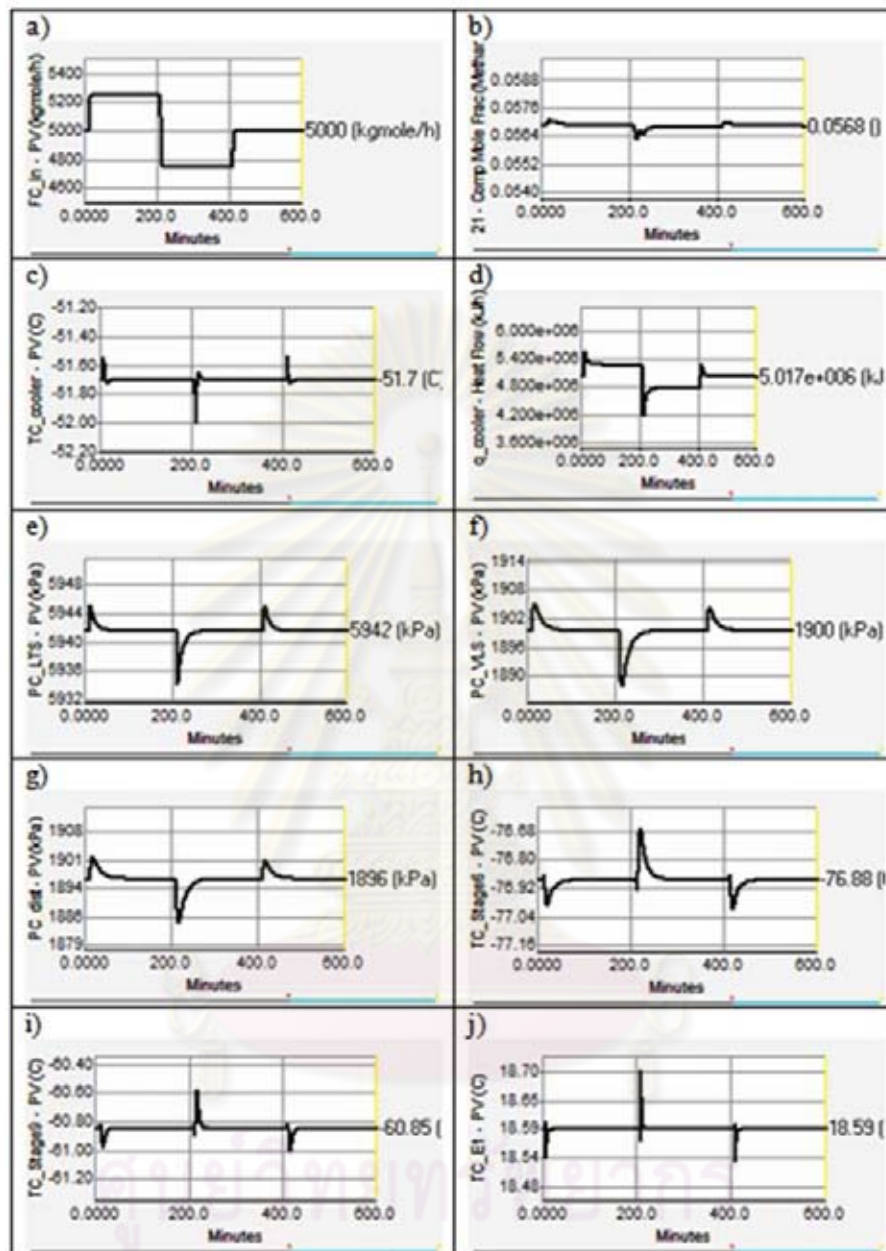

Figure 5.74: Dynamic responses of the natural gas expander plant (Alt7) to a change in the natural gas feed flow rate: CS₂, where: (a) the variation natural gas feed flow rate, (b) the methane impurity of product, (c) the LTS inlet temperature, (d) the cooler duty, (e) the LTS vessel pressure, (f) the VLS vessel pressure, (g) the DT top stage pressure, (h) the 6th stage temperature of DT, (i) the 9th stage temperature of DT, (j) the cold outlet temperature of exchanger E1

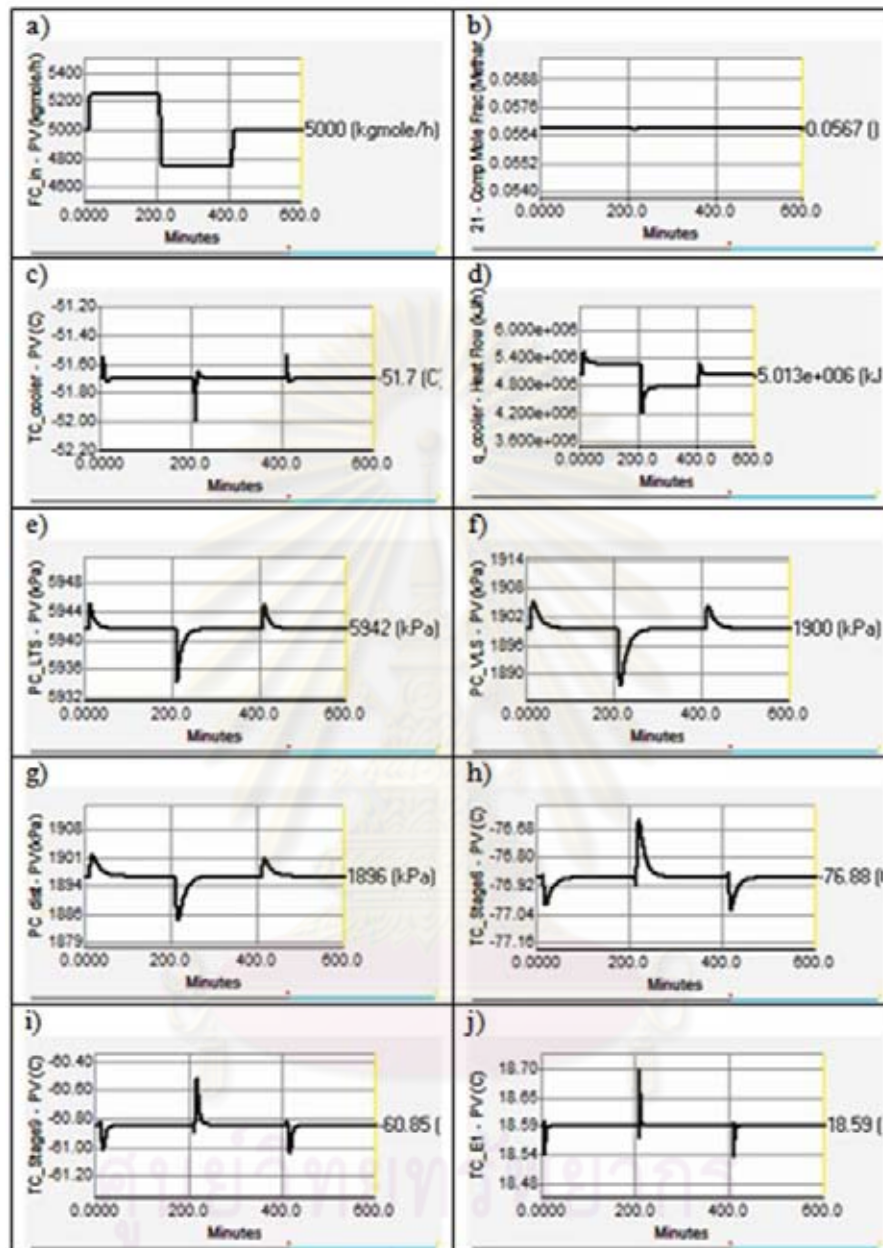

Figure 5.75: Dynamic responses of the natural gas expander plant (Alt7) to a change in the natural gas feed flow rate: CS3, where: (a) the variation natural gas feed flow rate, (b) the methane impurity of product, (c) the LTS inlet temperature, (d) the cooler duty, (e) the LTS vessel pressure, (f) the VLS vessel pressure, (g) the DT top stage pressure, (h) the 6th stage temperature of DT, (i) the 9th stage temperature of DT, (j) the cold outlet temperature of exchanger E1

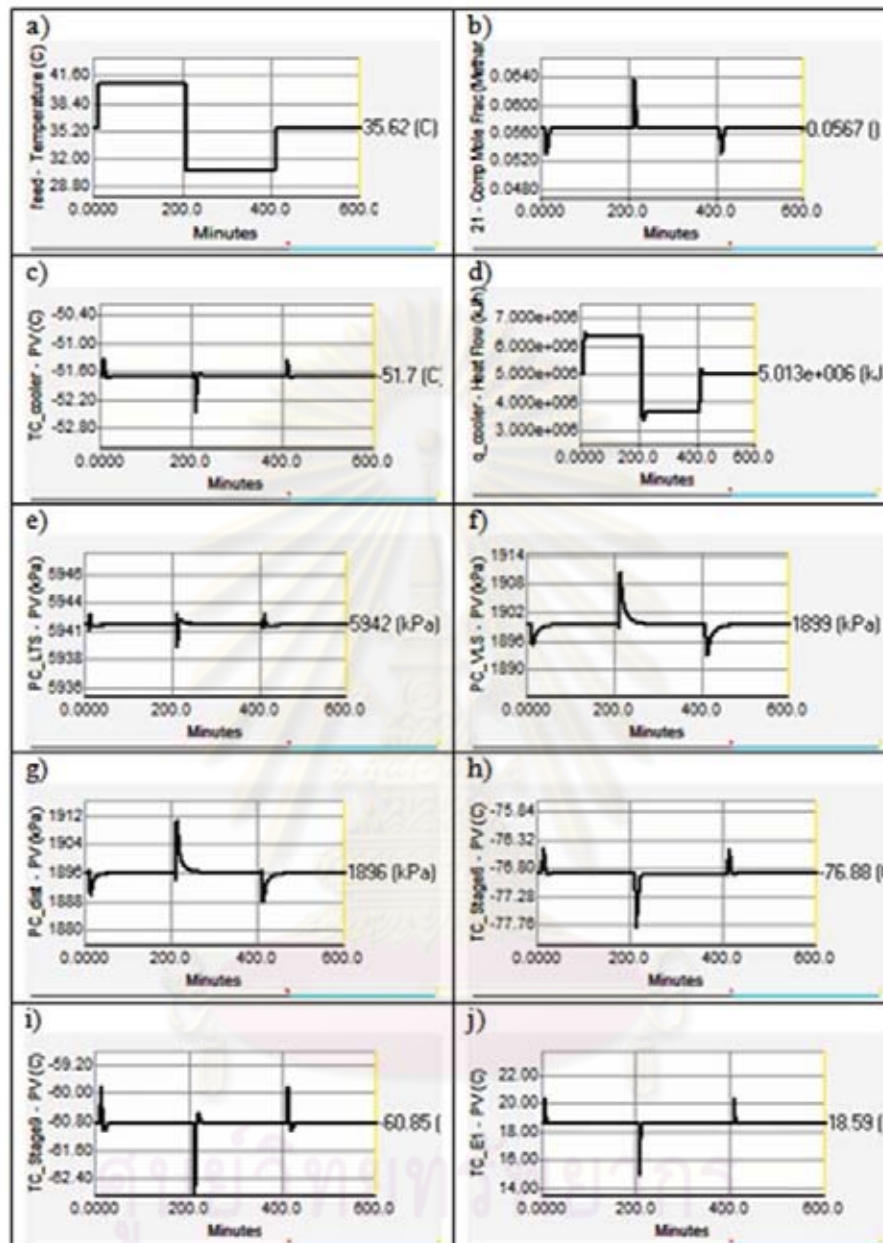

Figure 5.76: Dynamic responses of the natural gas expander plant (Alt8) to a change in the natural gas feed temperature: CS1, where: (a) the variation natural gas feed temperature, (b) the methane impurity of product, (c) the LTS inlet temperature, (d) the cooler duty, (e) the LTS vessel pressure, (f) the VLS vessel pressure, (g) the DT top stage pressure, (h) the 6th stage temperature of DT, (i) the 9th stage temperature of DT, (j) the cold outlet temperature of exchanger E1

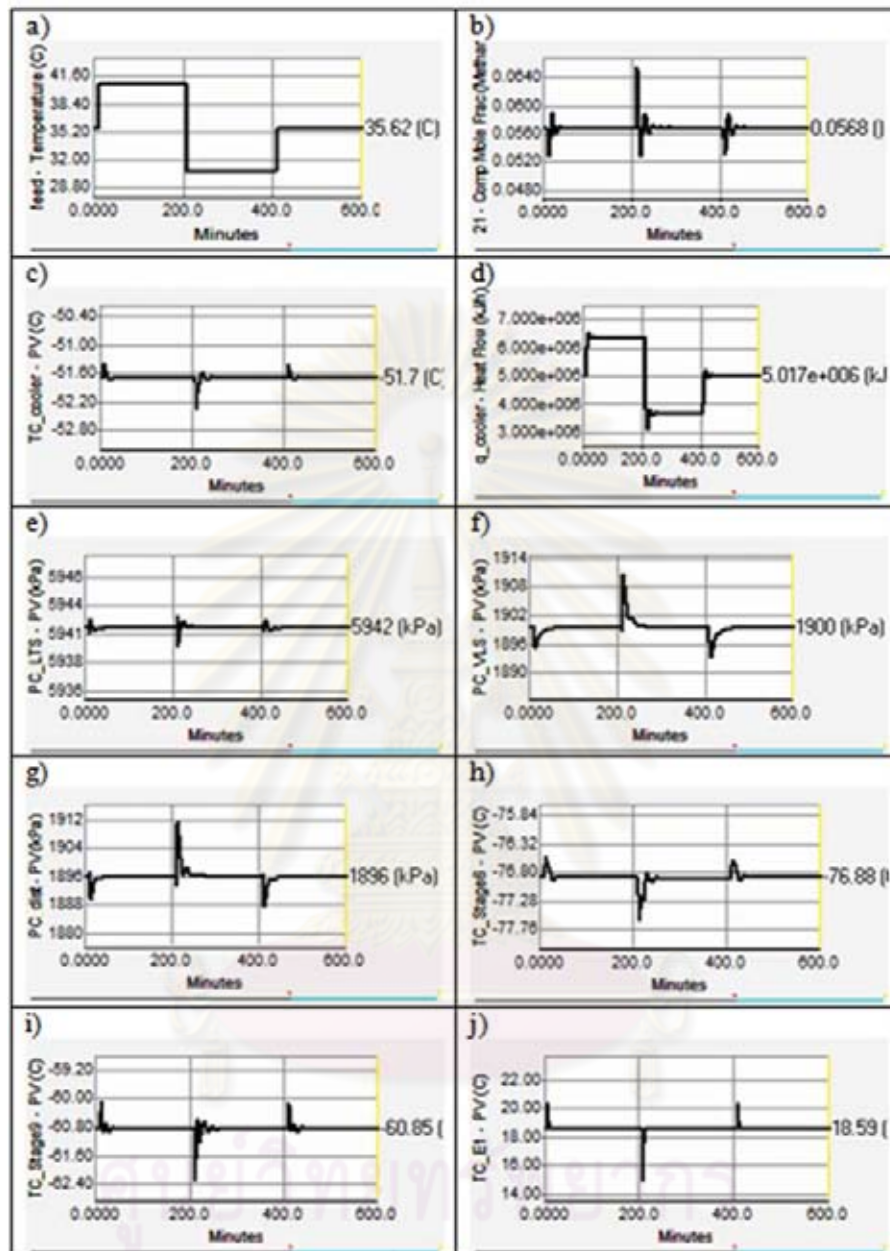

Figure 5.77: Dynamic responses of the natural gas expander plant (Alt8) to a change in the natural gas feed temperature: CS₂, where: (a) the variation natural gas feed temperature, (b) the methane impurity of product, (c) the LTS inlet temperature, (d) the cooler duty, (e) the LTS vessel pressure, (f) the VLS vessel pressure, (g) the DT top stage pressure, (h) the 6th stage temperature of DT, (i) the 9th stage temperature of DT, (j) the cold outlet temperature of exchanger E1

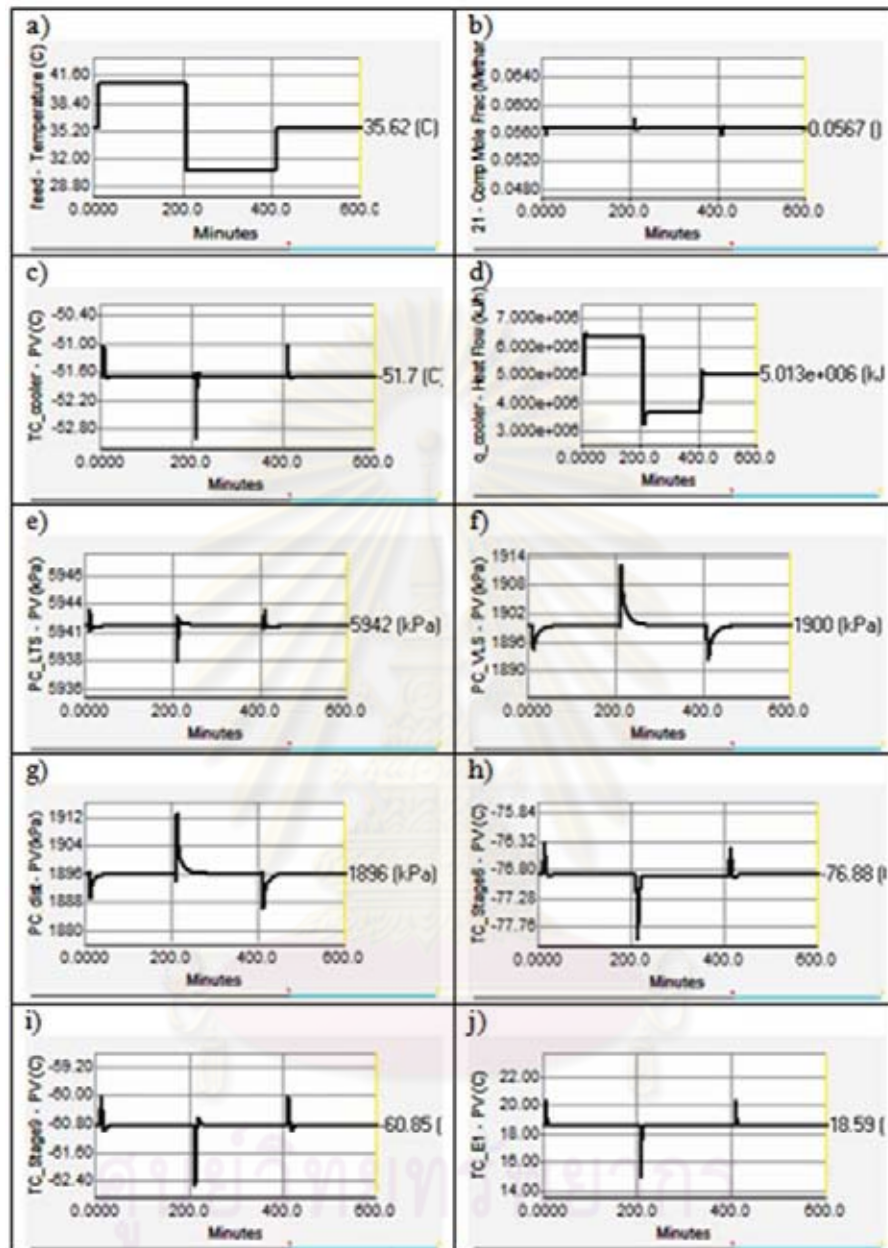

Figure 5.78: Dynamic responses of the natural gas expander plant (Alt8) to a change in the natural gas feed temperature: CS3, where: (a) the variation natural gas feed temperature, (b) the methane impurity of product, (c) the LTS inlet temperature, (d) the cooler duty, (e) the LTS vessel pressure, (f) the VLS vessel pressure, (g) the DT top stage pressure, (h) the 6th stage temperature of DT, (i) the 9th stage temperature of DT, (j) the cold outlet temperature of exchanger E1

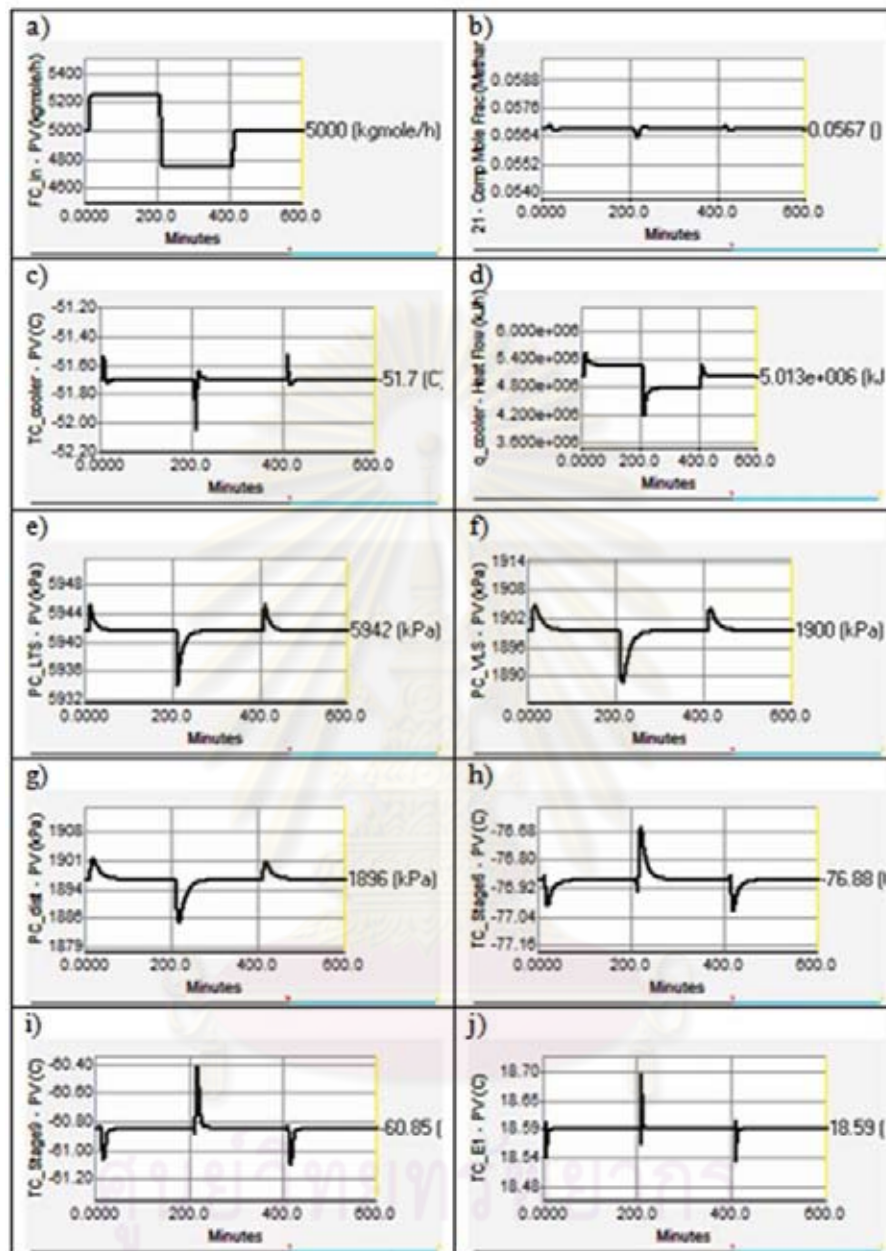

Figure 5.79: Dynamic responses of the natural gas expander plant (Alt8) to a change in the natural gas feed flow rate: CS1, where: (a) the variation natural gas feed flow rate, (b) the methane impurity of product, (c) the LTS inlet temperature, (d) the cooler duty, (e) the LTS vessel pressure, (f) the VLS vessel pressure, (g) the DT top stage pressure, (h) the 6th stage temperature of DT, (i) the 9th stage temperature of DT, (j) the cold outlet temperature of exchanger E1

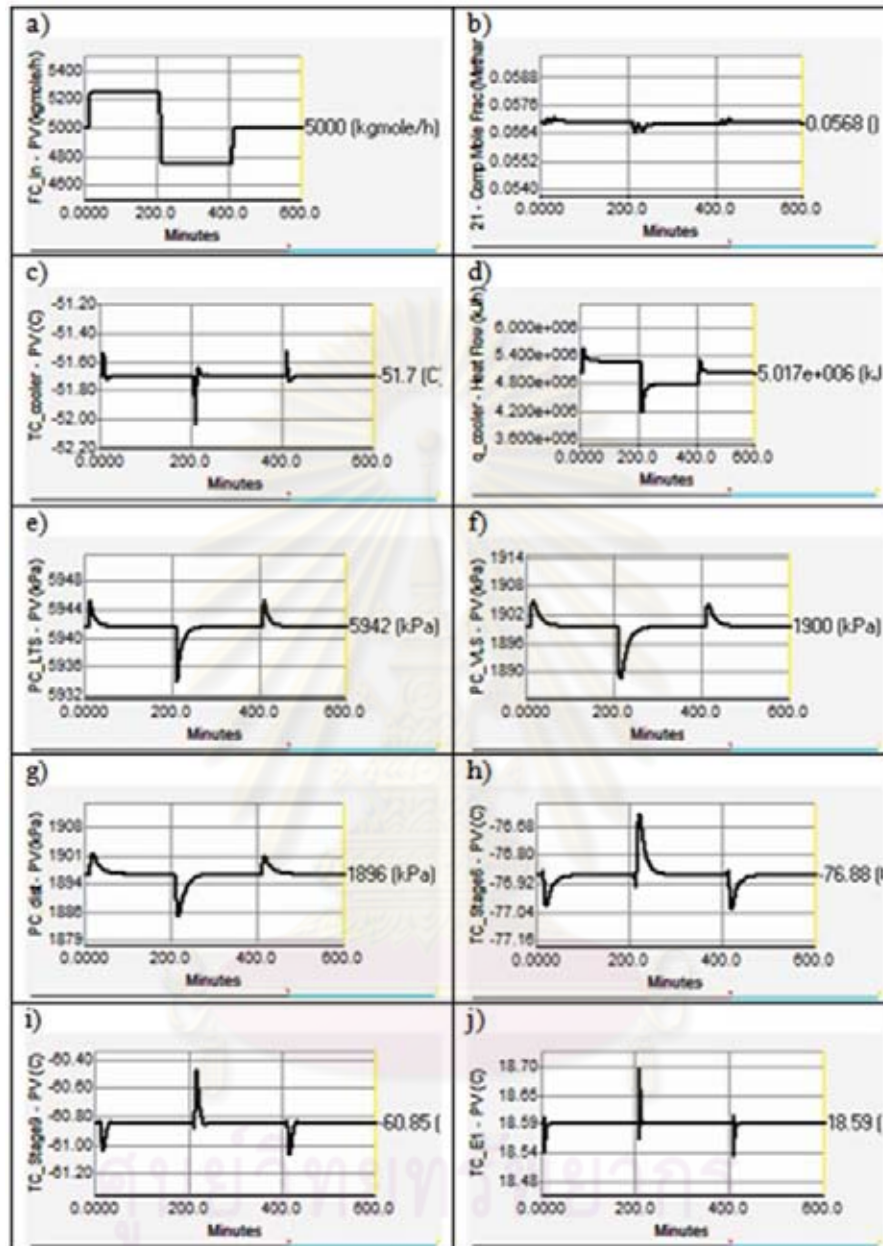

Figure 5.80: Dynamic responses of the natural gas expander plant (Alt8) to a change in the natural gas feed flow rate: CS₂, where: (a) the variation natural gas feed flow rate, (b) the methane impurity of product, (c) the LTS inlet temperature, (d) the cooler duty, (e) the LTS vessel pressure, (f) the VLS vessel pressure, (g) the DT top stage pressure, (h) the 6th stage temperature of DT, (i) the 9th stage temperature of DT, (j) the cold outlet temperature of exchanger E1

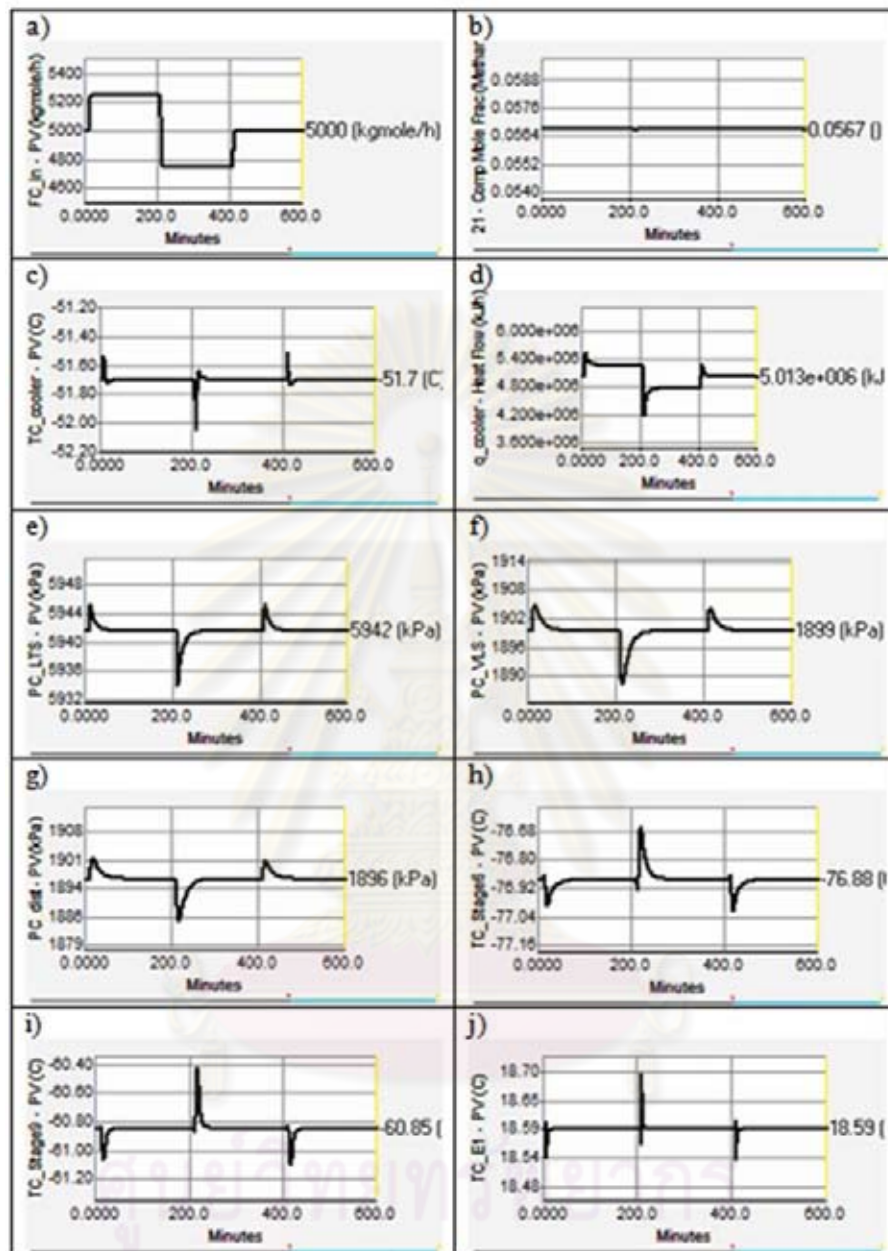

Figure 5.81: Dynamic responses of the natural gas expander plant (Alt8) to a change in the natural gas feed flow rate: CS3, where: (a) the variation natural gas feed flow rate, (b) the methane impurity of product, (c) the LTS inlet temperature, (d) the cooler duty, (e) the LTS vessel pressure, (f) the VLS vessel pressure, (g) the DT top stage pressure, (h) the 6th stage temperature of DT, (i) the 9th stage temperature of DT, (j) the cold outlet temperature of exchanger E1

5.4 Evaluation of the Dynamic Performance

The dynamic performance index is focused on time related characteristics of the controller's response to setpoint changes or deterministic disturbances. There exist several candidate performance measures such as settling time and integral absolute error (IAE). Integral absolute error is well known and widely used. For the formulation of a dynamic performance as written below:

$$IAE = \int |\epsilon(t)| dt \quad (5.1)$$

Note that $\epsilon(t) = y_{sp}(t) - y(t)$ is the deviation (error) of the response from the desired setpoint.

In this work, IAE method is used to evaluate the dynamic performance of the designed control systems. Table 5.10a to 5.12a shows the IAE results for the change in the natural gas feed temperature in the TEP with different alternatives (Basecase, Alt1, Alt2, Alt3, Alt4, Alt5, Alt6, Alt7 and Alt8) for CS1 control structure to CS3 control structure, respectively. Table 5.10b to 5.12b shows the IAE results for the change in the natural gas feed flow rate in the TEP with different alternatives (Basecase, Alt1, Alt2, Alt3, Alt4, Alt5, Alt6, Alt7 and Alt8) for CS1 control structure to CS3 control structure, respectively. Table 5.13 shows the IAE summation of the control structure to the change in all disturbances testing.

5.4.1 Evaluation of Dynamic Performance for CS1 Control Structure

For the change in the natural gas feed temperature (Table 5.10a), the IAE value of the TEP Alt4 is smaller than those of Alt3, Basecase, Alt5, Alt2, Alt1, Alt7, Alt6 and Alt8, respectively. Therefore, the dynamic performance of the TEP Alt4 is better than other alternatives for thermal disturbance rejection in

this control structure.

For the change in the natural gas feed flow rate (Table 5.10b), the IAE value of the TEP Alt4 is small than those of Alt3, Alt5, Alt2, Alt1, Alt7, Alt8, Alt6 and Basecase, respectively. Therefore, the dynamic performance of the TEP Alt4 is better than other alternatives for material flow disturbance rejection in this control structure.

As can be seen, the TEP Alt4 with CS1 control structure is the proper alternative for handling these disturbances (thermal and material disturbance).

5.4.2 Evaluation of Dynamic Performance for CS2 Control Structure

For the change in the natural gas feed temperature (Table 5.11a), the IAE value of the TEP Basecase is smaller than those of Alt4, Alt3, Alt5, Alt2, Alt1, Alt7, Alt6 and Alt8, respectively. Therefore, the dynamic performance of the TEP basecase is better than other alternatives for thermal disturbance rejection in this control structure.

For the change in the natural gas feed flow rate (Table 5.11b), the IAE value of the TEP Alt4 is small than those of Alt3, Alt7, Alt5, Alt2, Alt1, Alt8, Alt6 and Basecase, respectively. Therefore, the dynamic performance of the TEP Alt4 is better than other alternatives for material flow disturbance rejection in this control structure.

As can be seen, the TEP basecase with CS2 control structure is the proper alternative for handling the thermal disturbance and the TEP Alt4 is the proper alternative for handling the material flow disturbance.

5.4.3 Evaluation of Dynamic Performance for CS3 Control Structure

For the change in the natural gas feed temperature (Table 5.12a), the IAE value of the TEP Alt4 is smaller than those of Alt3, Basecase, Alt5, Alt2, Alt1, Alt7, Alt6 and Alt8, respectively. Therefore, the dynamic performance of the TEP Alt4 is better than other alternatives for material flow disturbance rejection in this control structure.

For the change in the natural gas feed flow rate (Table 5.12b), the IAE value of the TEP Alt5 is small than those of Alt3, Alt4, Alt2, Alt1, Alt7, Alt6, Alt8 and Basecase, respectively. Therefore, the dynamic performance of the TEP Alt5 is better than other alternatives for material flow disturbance rejection in this control structure.

As can be seen, the TEP Alt4 with CS3 control structure is the proper alternative for handling the thermal disturbance and the TEP Alt5 is the proper alternative for handling the material flow disturbance.

5.4.4 Evaluation of the Dynamic Performance for all Control Structures

In Table 5.13, as can be seen, the IAE of CS3 control structure is smaller than the IAE of CS1 and CS2 control structure for all alternatives. So, the CS3 control structure is the best control structure for disturbance handling because it gives better control performances. For the CS3 control structure, the IAE value of the TEP Alt4 is small than those of Alt3, Basecase, Alt5, Alt2, Alt1, Alt7, Alt6 and Alt8, respectively. So, the TEP Alt3 is the best alternative for the natural gas expander plant.

Table 5.10a: The IAE results of the CS1 control structure to the change in the natural gas feed temperature

Controller	Integral Absolute Error (IAE)								
	Bascase	Alt1	Alt2	Alt3	Alt4	Alt5	Alt6	Alt7	Alt8
PC_dist	1.0369	1.2091	1.2086	0.5454	0.5454	1.1518	1.0846	1.1489	1.0845
PC_LTS	1.0231	1.0724	0.8996	0.8648	0.7283	1.0396	1.1084	0.8907	1.0694
PC_VLS	1.0503	1.2044	1.2023	0.5517	0.5483	1.1466	1.0806	1.1423	1.0803
TC_cooler	0.9849	0.9900	0.9550	0.4110	0.5347	0.9936	1.1979	0.9641	1.1703
CC_21	0.3452	1.3826	1.3950	0.4756	0.4749	1.3535	1.3560	1.3614	1.3545
TC_E1	1.1470	1.0001	0.9790	1.0775	1.0814	0.9852	0.9554	0.9728	0.9538
TC_stage6	0.2840	0.8756	0.8504	0.6982	0.5578	0.8065	1.3553	1.4548	1.5620
TC_stage9	0.4385	1.3225	1.2568	0.9460	0.7309	1.1584	1.5237	1.3408	1.4481
Total	6.3100	9.0567	8.7466	5.5702	*5.2016	8.6353	9.6618	9.2759	9.7229

Note * = Minimum IAE value

Table 5.10b: The IAE results of the CS1 control structure to the change in the natural gas feed flow rate

Controller	Integral Absolute Error (IAE)								
	Bascase	Alt1	Alt2	Alt3	Alt4	Alt5	Alt6	Alt7	Alt8
PC_dist	0.9197	1.0898	1.0897	0.8964	0.8969	1.0502	1.0057	1.0491	1.0057
PC_LTS	0.9964	1.0000	0.9998	1.0113	1.0052	0.9979	0.9965	0.9968	0.9957
PC_VLS	0.9242	1.0868	1.0869	0.9000	0.8995	1.0484	1.0047	1.0471	1.0046
TC_cooler	1.1726	1.0329	1.0090	0.4643	0.5860	1.0492	1.2781	1.0283	1.2557
CC_21	3.6042	0.5031	0.5046	0.6375	0.6462	0.4684	0.4836	0.4848	0.4828
TC_E1	0.7148	1.0713	1.0575	0.8415	0.8918	1.0495	0.9763	1.0370	0.9704
TC_stage6	0.5501	0.9347	0.9625	0.9748	0.7335	0.8148	1.3848	1.1653	1.1394
TC_stage9	0.9643	1.1240	1.1219	0.9842	0.7526	0.7621	1.1887	1.2549	1.2354
Total	9.8463	7.8425	7.8319	6.7100	*6.4116	7.2403	8.3184	8.0632	8.0896

Note * = Minimum IAE value

Table 5.11a: The IAE results of the CS2 control structure to the change in the natural gas feed temperature

Controller	Integral Absolute Error (IAE)								
	Bascase	Alt1	Alt2	Alt3	Alt4	Alt5	Alt6	Alt7	Alt8
PC_dist	1.0362	1.2069	1.2067	0.5440	0.5447	1.1498	1.0833	1.1474	1.0832
PC.LTS	0.9768	1.0124	0.9892	1.2119	0.9460	0.9878	1.1281	0.9752	1.1324
PC.VLS	1.0493	1.2012	1.2010	0.5513	0.5484	1.1440	1.0796	1.1411	1.0797
TC_cooler	1.0022	1.3050	1.2781	0.6533	0.6722	1.2505	1.4792	1.2100	1.4555
CC_21	0.4311	2.2730	2.2381	1.1143	0.9614	2.4068	2.4123	2.2158	2.3661
TC.E1	1.1417	1.0161	1.0160	1.2163	1.2064	0.9997	0.9754	1.0022	0.9779
TC_stage6	0.2803	1.0659	1.0766	0.8052	0.7331	1.0522	1.5218	1.5669	1.7763
TC_stage9	0.3934	1.1865	1.0828	0.8230	0.7112	1.0661	1.2566	0.9035	1.1772
Total	*6.3110	10.2671	10.0884	6.9193	6.3234	10.0569	10.9362	10.1621	11.0483

Note * = Minimum IAE value

Table 5.11b: The IAE results of the CS2 control structure to the change in the natural gas feed flow rate

Controller	Integral Absolute Error (IAE)								
	Bascase	Alt1	Alt2	Alt3	Alt4	Alt5	Alt6	Alt7	Alt8
PC_dist	0.9188	1.0882	1.0882	0.8962	0.8967	1.0488	1.0046	1.0476	1.0047
PC.LTS	0.9969	0.9999	0.9993	1.0107	1.0026	0.9971	0.9983	0.9971	0.9971
PC.VLS	0.9232	1.0857	1.0855	0.9003	0.8995	1.0473	1.0040	1.0461	1.0039
TC_cooler	1.3907	1.0575	1.0432	0.6785	0.7683	1.0552	1.2719	1.0146	1.2621
CC_21	4.1508	1.4199	1.4660	2.0828	2.0965	1.3629	1.2914	1.4999	1.3191
TC.E1	0.8555	1.0746	1.0768	0.9212	0.9761	1.0513	0.9593	1.0463	0.9750
TC_stage6	0.5521	0.9924	0.9813	0.9881	0.8623	1.0199	1.5113	1.1593	1.4717
TC_stage9	1.0796	1.0806	0.9670	0.9148	0.7653	1.0433	1.3376	0.6957	1.0950
Total	10.8676	8.7988	8.7073	8.3926	*8.2672	8.6257	9.3783	8.5067	9.1285

Note * = Minimum IAE value

Table 5.12a: The IAE results of the CS3 control structure to the change in the natural gas feed temperature

Controller	Integral Absolute Error (IAE)								
	Bascase	Alt1	Alt2	Alt3	Alt4	Alt5	Alt6	Alt7	Alt8
PC.dist	1.0367	1.2054	1.2051	0.5406	0.5391	1.1478	1.0817	1.1449	1.0814
PC.LTS	1.0729	0.9389	0.9399	0.9763	0.7924	0.9331	1.2156	0.8858	1.1891
PC.VLS	1.0506	1.2022	1.2020	0.5472	0.5466	1.1450	1.0815	1.1418	1.0807
TC.cooler	1.0128	1.0398	1.0377	0.3789	0.4903	1.0401	1.2397	1.0119	1.2413
CC.21	0.2241	0.1290	0.1277	0.0532	0.0516	0.1366	0.1235	0.1235	0.1131
TC.E1	0.9336	0.9876	1.0018	0.7880	0.6696	0.9846	0.9640	0.9955	0.9714
TC.stage6	0.2417	0.9053	0.8704	0.6946	0.6752	0.9042	1.2991	1.4890	1.5979
TC.stage9	0.3483	1.1106	0.9945	0.8032	0.6642	0.8945	1.2034	1.0087	1.2069
Total	5.9206	7.5187	7.3791	4.7820	*4.4288	7.1859	8.2086	7.8009	8.4817

Note * = Minimum IAE value

Table 5.12b: The IAE results of the CS3 control structure to the change in the natural gas feed flow rate

Controller	Integral Absolute Error (IAE)								
	Bascase	Alt1	Alt2	Alt3	Alt4	Alt5	Alt6	Alt7	Alt8
PC.dist	0.9198	1.0896	1.0897	0.8963	0.8968	1.0502	1.0056	1.0492	1.0058
PC.LTS	0.9965	0.9997	0.9996	1.0136	1.0037	0.9980	0.9963	0.9971	0.9969
PC.VLS	0.9243	1.0869	1.0867	0.9003	0.8995	1.0483	1.0046	1.0471	1.0047
TC.cooler	1.0902	1.0249	1.0227	0.3713	0.4862	1.0523	1.2572	1.0108	1.2666
CC.21	1.8425	0.0726	0.0773	0.1053	0.1112	0.0878	0.0637	0.0740	0.0612
TC.E1	0.6250	1.0490	1.0568	1.3425	1.3404	1.0516	0.9668	1.0456	0.9763
TC.stage6	0.4354	0.9468	0.9178	0.9929	0.9313	0.9564	1.1604	1.3751	1.0857
TC.stage9	0.8387	1.0733	0.9629	0.9899	0.7397	0.6635	1.1655	0.9477	1.2519
Total	7.6723	7.3428	7.2136	6.6121	*6.4090	6.9081	7.6200	7.5466	7.6490

Note * = Minimum IAE value

Table 5.13: The IAE summation of the control structure to the change in all disturbances testing

Control Structure	Integral Absolute Error (IAE)								
	Bascase	Alt1	Alt2	Alt3	Alt4	Alt5	Alt6	Alt7	Alt8
CS1	16.1563	16.8992	16.5785	12.2801	*11.6132	15.8756	17.9802	17.3391	17.8125
CS2	17.1786	19.0658	18.7957	15.3119	*14.5906	18.6826	20.3146	18.6689	20.1768
CS3	13.5929	14.8615	14.5926	11.3940	*10.8378	14.0940	15.8286	15.3475	16.1307

Note * = Minimum IAE value

CHAPTER VI

CONCLUSIONS AND RECOMMENDATIONS

6.1 Conclusion

This study considers the heat integrated process design altogether with plantwide control structure selection for reduction of energy consumption and maintaining good control performance. We look at 9 alternatives of various heat integrated processes (base case by Akman and Konukman (2005), 8 alternative designs) and 3 plantwide control structure designs. Two kinds of disturbances are used: thermal disturbance and the material flow disturbance. The HEN design follows Wongsri's resilient HEN synthesis method (1990). The HEN design saves energy equally but it will be different at the heat exchanger type in the process. The base case alternative use utility heat exchanger but alternative designs use process-to-process heat exchanger, which the alternative designs will have cost of the production less than the base case alternative. The thermal load management of the resilient HEN, in and out, and to thermal sinks and sources uses Heat Pathway Heuristics (HPH) (Wongsri and Hermawan, 2005). In general, the HPH is very useful in terms of heat load or disturbance management to achieve the highest possible dynamic MER.

The natural gas expander plant is selected to illustrate the concepts, the design procedures and the analysis is illustrated using time domain simulation-based approach through HYSYS rigorous dynamic simulator. Although heat integration process is difficult to control, but proper control structure can reduce complication for complex heat integration process control and achieve to design objectives. However, the energy usage is important to consider because the good control structure with heat integration process is less energy consumption, namely decreasing operation cost.

For the thermal disturbance, CS3 control structure are the proper control structure with all alternatives, their feature structure are the cascade between methane impurity in the product and DT bottom tray temperature so it can reject the thermal disturbance by keeping the composition constant. For considering the alternatives, the TEP alternative 4 gives the IAE value smaller than other alternatives, so the alternative 4 is the best heat exchanger network for the change in thermal disturbance.

For the material flow disturbance, we can conclude that the CS3 control structure is better than other structures because the material disturbance entered is immediately directed out of the DT. In the same way, the TEP alternative 5 gives the IAE value smaller than other alternatives, so the alternative 5 is the best heat exchanger network for the change in material flow disturbance.

For all disturbances testing, the TEP alternative 4 gives the IAE value smaller than other alternatives. Therefore, the TEP alternative 4 is the proper heat exchanger network for all control structures.

6.2 Recommendations

1. Study and design the control structure of complex heat-exchanger networks of the other process in plantwide control point of view. Maintain process variable at desired values.
2. Study the controllability characteristics of energy-integrated natural gas expander plant.

REFERENCES

- Akman, U., and Konukman, A.E.S. Flexibility and Operability Analysis of a HEN-integrated Natural Gas Expander Plant. Chem. Eng. Sci. 60 (2000): 7057-7074.
- Alongkorn Ploypaisansang. Resilient Heat Exchanger Network Design of Hydrodealkylation Process. Master's Thesis, Department of Chemical Engineering, Engineering, Chulalongkorn University, 2003.
- Calandranis, J., and Stephanopoulos, G. A Structure Approach to the Design of Control System in Heat Exchanger Networks. Comput. Chem. Eng. 12 (1988): 651-669.
- Chakkraphong Thaicharoen. Design of Control Structure for Energy-Integrated Hydrodealkylation (HDA) Process. Master's Thesis. Department of Chemical Engineering, Engineering, Chulalongkorn University, 2004.
- Douglas, J.M. Conceptual Design of Chemical Process. New York: McGraw-Hill, 1988.
- Floudas, C.A., and Grossmann, I.E. Synthesis of Flexible Heat Exchanger Networks with Uncertain Flowrates and Temperatures. Comput. Chem. Eng. 11(4) (1987): 319-336.
- Handogo, R., and Luyben W.L. Design and Control of a Heat-Integrated Reactor /Column Process. Ind. Eng. Chem. Res. 26 (1987): 531-538.
- Jatuporn Kunlawaniteewat. Heat Exchanger Network Control Structure Design. Master's Thesis, Department of Chemical Engineering, Engineering, Chulalongkorn University, 2001.
- Jones, W.E., and Wilson, J.A. An Introduction to Process Flexibility: Heat Exchanger. Chem. Eng. Ed. 31 (1997): 172-177.

- Linnhoff, B., Dunford, H., and Smith, R. Heat Integration of Distillation Columns into Overall Processes. Chem. Eng. Sci. 38 (1983): 1175.
- Linnhoff, B., and Hindmarsh, E. The Pinch Design Method for Heat Exchanger Networks. Chem. Eng. Sci. 38 (1983): 1175-1188.
- Linnhoff, B., and Kotjabasakis, E. Design of Operable Heat Exchanger Networks. First U.K. National Heat Transfer Conference I. Chem. E. Symp. Ser. 86 (1984): 599.
- Luyben, M.L., and Luyben, W.L. Design and Control of a Complex Process Involving Two Reaction Steps, Three Distillation Columns and Two Recycle Streams. Ind. Eng. Chem. Res. 34 (1995): 3885-3898.
- Luyben, M.L., Tyreus, B.D., and Luyben, W.L. Plantwide Process Control. New York: McGraw-Hill, 1999.
- Luyben, M.L., Tyreus, B.D., and Luyben, W.L. Design Plantwide Control Procedure. AIChE Journal. 43 (1997): 3161-3174.
- Luyben, W.L. Control of Outlet Temperature in Adiabatic Tubular Reactor. Ind. Eng. Chem. Res. 39 (2000): 1271-1278.
- Luyben, W.L. Design and Control of Gas-Phase Reactor/Recycle Process with Reversible Exothermic Reactions. Ind. Eng. Chem. Res. 39 (2000): 1529-1538.
- Luyben, W.L. Plantwide Dynamic Simulations in Chemical Processing and Control. New York: Marcel Dekker, 2002.
- Marselle, D.F., Morari, M., and Rudd, D.F. Design of Resilient Processing Plants II: Design and Control of Energy and Management Systems. Chem. Eng. Sci. 37 (1982): 259.
- Montree Wongsri. Resilient of Heat Exchanger Network Design. Doctoral dissertation, Sever Institute of Technology, Science, Washington University, 1990.

- Richard Dale Colberg. Area, Cost and Resilience Targets for Heat Exchanger Networks. Doctoral dissertation, Cal Tech, Pasadena, 1989.
- Saboo, A.K., and Morari, M. Design of Resilient Processing Plants IV: Some New Results on Heat Exchanger Network Synthesis. Chem. Eng. Sci. 3 (1984): 579-592.
- Sayfon Kietawarin. Control Structure Design Applied to Hydrodealkylation Process Plantwide Control Problem. Master's Thesis, Department of Chemical Engineering, Engineering, Chulalongkorn University, 2002.
- Seborg, D.E., Edgar, T.F., and Mellichamp, D.A. Process Dynamic and Control. New York: John Wiley & Sons, (1989).
- Skogestad, S. Control structure design for complete chemical plants. Comput. Chem. Eng. 28 (2004): 219-234.
- Terrill, D.L., and Douglas, J.M. A T-H Method for Heat Exchanger Network Synthesis. Ind. Eng. Chem. Res. 26 (1987): 175-179.
- Wongsri, M., and Hermawan, Y. D. Heat Pathway Management for Complex Energy Integrated Plant: Dynamic Simulation of HDA Plant. J. Chin. Inst. Chem. Engrs. 36 (2005): 1-27.
- Wongsri, M., and Sae-Leaw, B. Design of Control Structures of Energy-integrated HDA Plant with Minimum Auxiliary Reboilers. Master's Thesis, Department of Chemical Engineering, Engineering, Chulalongkorn University, 2006.



APPENDICES

ศูนย์วิทยทรัพยากร
จุฬาลงกรณ์มหาวิทยาลัย

APPENDIX A

PARAMETER TUNING

A.1 Tuning Controllers

Notice throughout this work uses several types of controllers such as P, PI, and PID controllers. They depend on the control loop. In theory, control performance can be improved by the use of derivative action but in practice the use of derivative has some significant drawbacks:

1. Three tuning constants must be specified.
2. Signal noise is amplified.
3. Several types of PID control algorithms are used, so important to careful that the right algorithm is used with its matching tuning method.
4. The simulation is an approximation of the real plant. If high performance controllers are required to get good dynamics from the simulation, the real plant may not work well.

A.2 Tuning Flow, Level and Pressure Loops

The dynamics of flow measurement are fast. The time constants for moving control valves are small. Therefore, the controller can be turned with a small integral or reset time constant. A value of $\tau = 0.3$ minutes work in most controllers. The value of controller gain should be kept modest because flow measurement signal are sometime noisy due to the turbulent flow through the orifice plate. A value of controller gain of $KC = 0.5$ is often used. Derivative action should not be used.

Most level controllers should use proportional-only action with a gain of 1 to 2. This provides the maximum amount of flow smoothing. Proportional control means there will be steady state offset (the level will not be returned to its setpoint value). However, maintaining a liquid level at a certain value is often not necessary when the liquid capacity is simply being used as surge volume. So the recommended tuning of a level controller is $K_C = 2$. Most pressure controllers can be fairly easily tuned. The process time constant is estimated by dividing the gas volume of the system by the volumetric flowrate of gas flowing through the system. Setting the integral time equal to about 2 to 4 times the process time constant and using a reasonable controller gain usually gives satisfactory pressure control. Typical pressure controller tuning constants for columns and tanks are $K_C = 2$ and $T_i = 10$ minutes.

A.3 Relay- Feedback Testing

The relay-feedback test is a tool that serves a quick and simple method for identifying the dynamic parameters that are important for to design a feedback controller. The results of the test are the ultimate gain and the ultimate frequency. This information is usually sufficient to permit us to calculate some reasonable controller tuning constants.

The method consists of merely inserting an on-off relay in the feedback loop. The only parameter that must be specified is the height of the relay, h . This height is typically 5 to 10 percent of the controller output scale. The loop starts to oscillate around the setpoint with the controller output switching every time the process variable (PV) signal crosses the setpoint. Figure B.1 shows the PV and OP signals from a typical relay-feedback test. The maximum amplitude (a) of the PV signal is used to calculate the ultimate gain, K_U from the equation

$$K_u = \frac{4h}{a\pi} \quad (1)$$

The period of the output PV curve is the ultimate period, P_u from these two parameters controller tuning constants can be calculated for PI and PID controllers, using a variety of tuning methods proposed in the literature that require only the ultimate gain and the ultimate frequency, e.g. Ziegler-Nichols, Tyreus-Luyben.

$$K_C = K_U/2.2 \quad (2)$$

$$T_i = P_U/1.2 \quad (3)$$

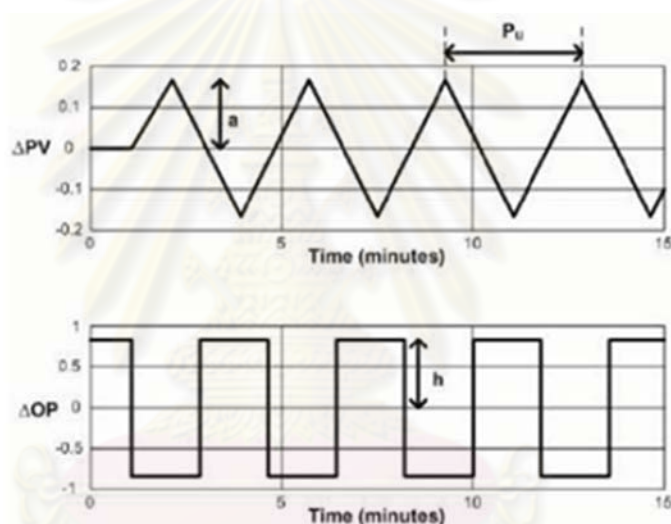

Figure A.1: Input and Output from Relay-Feedback Test

A.4 Inclusion of Lags

Any real physical system has many lags. Measurement and actuator lags always exist. In simulations, however, these lags are not part of the unit models. Much more aggressive tuning is often possible on the simulation than is possible in the real plant. Thus the predictions of dynamic performance can be overly optimistic. This is poor engineering. A conservative design is needed. Realistic dynamic simulations require that we explicitly include lags and/or dead times in all the important loops. Usually this means controllers that affect product quality

or process constraint. Table A.1 summarizes some recommended lags to include in several different types of control loops.

Table A.1: Typical measurement lags

		Number	Time constant (minutes)	Type
Temperature	Liquid	2	0.5	First-Order Lag
	Gas	3	1	First-Order Lag
Composition	Chromatograph	1	3 to 10	Deadtime



ศูนย์วิทยทรัพยากร
จุฬาลงกรณ์มหาวิทยาลัย

APPENDIX B

PROCESS AND EQUIPMENT DATA OF NATURAL GAS EXPANDER PLANT

Table B.1: Data of the natural gas expander plant (Base Case) for simulation

Streams & conditions	Natural gas feed (Stream 1)	Methane-rich residue (Stream 25)	Ethane-rich product (Stream 21)
Vapor fraction	0.9975	1	0
Temperature [$^{\circ}C$]	35	40.8	-7.7
Pressure [atm]	60	22.1	19.1
Molar flow [kgmol/h]	5000	4342.9	657.1
Components	Mole fractions		
Nitrogen	0.00550	0.00633	0.00000
CO ₂	0.00910	0.00598	0.02973
Methane	0.84570	0.96497	0.05741
Ethane	0.08200	0.02195	0.47886
Propane	0.03400	0.00074	0.25382
<i>i</i> -Butane	0.00580	0.00002	0.04403
<i>n</i> -Butane	0.00860	0.00001	0.06538
<i>i</i> -Pentane	0.00280	0.00000	0.02130
<i>n</i> -Pentane	0.00210	0.00000	0.01598
<i>n</i> -Hexane	0.00180	0.00000	0.01370
<i>n</i> -Heptane	0.00120	0.00000	0.00913
<i>n</i> -Octane	0.00050	0.00000	0.00381
<i>n</i> -Nonane	0.00040	0.00000	0.00304
<i>n</i> -Decane	0.00050	0.00000	0.00381

Table B.2: Equipment data and specifications of natural gas expander plant

Equipment	Specification	Value
Low-temperature separator (LTS)	Vessel Volume (m ³)	12.95
Vapor-liquid separator (VLS)	Vessel Volume (m ³)	12.95
Demethanizer Tower (DT)	Tray Volume (m ³)	0.9719
	Column Diameter (m)	1.5
	Reboiler Volume (m ³)	9.12
<i>Basecase</i>		
Heat Exchanger E1	UA (kJ/C-h)	1.5e06
Heat Exchanger E2	UA (kJ/C-h)	1e06
<i>Alt1</i>		
Heat Exchanger E1	UA (kJ/C-h)	7.163e05
Heat Exchanger E2	UA (kJ/C-h)	6.956e05
Heat Exchanger E3	UA (kJ/C-h)	3.546e05
Heat Exchanger E4	UA (kJ/C-h)	9.122e04
Heat Exchanger E5	UA (kJ/C-h)	4.268e04
<i>Alt2</i>		
Heat Exchanger E1	UA (kJ/C-h)	7.163e05
Heat Exchanger E2	UA (kJ/C-h)	6.956e05
Heat Exchanger E3	UA (kJ/C-h)	3.546e05
Heat Exchanger E4	UA (kJ/C-h)	3.910e04
Heat Exchanger E5	UA (kJ/C-h)	1.234e05
<i>Alt3</i>		
Heat Exchanger E1	UA (kJ/C-h)	1.750e06
Heat Exchanger E2	UA (kJ/C-h)	5.460e05
Heat Exchanger E3	UA (kJ/C-h)	9.122e04
Heat Exchanger E4	UA (kJ/C-h)	4.268e04
<i>Alt4</i>		
Heat Exchanger E1	UA (kJ/C-h)	1.750e06

Equipment	Specification	Value
Heat Exchanger E2	UA (kJ/C-h)	5.460e05
Heat Exchanger E3	UA (kJ/C-h)	3.910e04
Heat Exchanger E4	UA (kJ/C-h)	1.234e05
<i>Alt5</i>		
Heat Exchanger E1	UA (kJ/C-h)	7.163e05
Heat Exchanger E2	UA (kJ/C-h)	6.956e05
Heat Exchanger E3	UA (kJ/C-h)	3.467e04
Heat Exchanger E4	UA (kJ/C-h)	4.389e05
Heat Exchanger E5	UA (kJ/C-h)	4.268e04
<i>Alt6</i>		
Heat Exchanger E1	UA (kJ/C-h)	7.163e05
Heat Exchanger E2	UA (kJ/C-h)	6.956e05
Heat Exchanger E3	UA (kJ/C-h)	3.467e04
Heat Exchanger E4	UA (kJ/C-h)	2.543e04
Heat Exchanger E5	UA (kJ/C-h)	6.203e05
<i>Alt7</i>		
Heat Exchanger E1	UA (kJ/C-h)	7.163e05
Heat Exchanger E2	UA (kJ/C-h)	6.956e05
Heat Exchanger E3	UA (kJ/C-h)	2.374e04
Heat Exchanger E4	UA (kJ/C-h)	4.368e05
Heat Exchanger E5	UA (kJ/C-h)	1.234e05
<i>Alt8</i>		
Heat Exchanger E1	UA (kJ/C-h)	7.163e05
Heat Exchanger E2	UA (kJ/C-h)	6.956e05
Heat Exchanger E3	UA (kJ/C-h)	2.374e04
Heat Exchanger E4	UA (kJ/C-h)	3.853e04
Heat Exchanger E5	UA (kJ/C-h)	6.203e05

APPENDIX C

FIXTURE POINT THEOREM DATA

Table C.1: List of Manipulated Variables for the TEP

Manipulated Variable	Description
V1	Natural gas feed valve
V2	LTS bottom valve
V3	VLS bottom valve
V4	VLS overhead valve
V5	DT overhead valve
V6	E2 bypass cold stream valve
V7	E1 bypass cold stream valve
V8	DT bottom valve
70	Expander power (E-100)
Q-80	Heat duty of exchanger E-101
Q-81	Heat duty of exchanger E-102
Q-82	Heat duty of exchanger E-104
Q-83	Heat duty of exchanger E-103 (cooler duty)

ศูนย์วิจัยทรัพยากร
จุฬาลงกรณ์มหาวิทยาลัย

Table C.2: IAE Results of Flow Rate Deviation for the Process Stream

Stream	V1	V2	V3	V4	V5	V6	V7	V8	70	Q-80	Q-81	Q-82	Q-83	Sum IAE
1	1.3120	1.5902	0.8566	1.5191	1.0008	1.9206	2.0533	1.0415	1.6721	1.8112	2.0829	2.0888	1.8629	20.8119
2	0.6834	0.8193	0.4410	0.7821	0.5152	0.9887	1.0571	0.5364	0.8610	0.8383	1.0723	1.0754	0.9596	10.6298
3	0.6286	0.7709	0.4155	0.7369	0.4854	0.9316	0.9960	0.5051	0.8111	0.9734	1.0104	1.0133	0.9033	10.1814
4	0.6279	0.7709	0.4156	0.7370	0.4856	0.9319	0.9962	0.5052	0.8111	0.9734	1.0106	1.0134	0.9034	10.1823
5	0.6277	0.7709	0.4156	0.7370	0.4856	0.9319	0.9962	0.5053	0.8111	0.9735	1.0107	1.0135	0.9034	10.1823
6	0.6825	0.8191	0.4410	0.7822	0.5152	0.9888	1.0572	0.5374	0.8610	0.8382	1.0723	1.0754	0.9595	10.6299
7	1.3103	1.5901	0.8566	1.5191	1.0008	1.9207	2.0534	1.0428	1.6721	1.8111	2.0830	2.0889	1.8629	20.8117
8	0.7050	0.8267	0.4450	0.7951	0.5198	1.0730	1.0426	0.5408	0.8779	0.9269	1.0506	1.0981	0.8414	10.7429
9	0.6055	0.7634	0.4116	0.7239	0.4808	0.8475	1.0105	0.5020	0.7942	0.8842	1.0321	0.9906	1.0224	10.0688
10	0.6058	0.7635	0.4116	0.7240	0.4810	0.8479	1.0108	0.5032	0.7942	0.8843	1.0324	0.9908	1.0224	10.0720
11	0.6073	0.7636	0.4116	0.7241	0.4810	0.8482	1.0109	0.5047	0.7943	0.8843	1.0325	0.9909	1.0225	10.0758
12	0.7057	0.8288	0.4451	0.7954	0.5200	1.0733	1.0423	0.5448	0.8779	0.9275	1.0505	1.0980	0.8423	10.7515
13	1.3127	1.5922	0.8566	1.5192	1.0007	1.9208	2.0529	1.0492	1.6721	1.8118	2.0828	2.0887	1.8638	20.8236
14	0.5766	0.7393	0.0276	0.0939	0.0301	0.0031	0.0627	0.0175	0.1161	0.1457	0.1277	0.1208	0.1575	2.2186
15	1.6957	1.5227	0.5619	1.4949	0.6466	1.4620	1.3348	0.6782	1.8355	1.5042	1.0829	1.1394	1.5497	16.5084
16	0.5766	0.7393	0.0276	0.0939	0.0301	0.0031	0.0627	0.0175	0.1161	0.1457	0.1277	0.1208	0.1575	2.2186
17	1.6957	1.5227	0.5619	1.4949	0.6466	1.4620	1.3348	0.6782	1.8355	1.5042	1.0829	1.1394	1.5497	16.5084
18	0.3726	0.1853	3.2058	0.8136	2.4487	0.1266	0.0894	0.4894	0.1481	0.0967	0.0583	0.0469	0.0934	8.1748
18C	0.3726	0.1853	3.2058	0.8136	2.4487	0.1266	0.0894	0.4894	0.1481	0.0967	0.0583	0.0469	0.0934	8.1748
18D	0.3726	0.1853	3.2058	0.8136	2.4487	0.1266	0.0894	0.4894	0.1481	0.0967	0.0583	0.0469	0.0934	8.1748
19	2.2710	1.4504	0.3499	1.4461	0.4194	1.3267	1.1236	0.9124	1.7685	1.3139	0.7859	0.8188	1.3417	15.3282
20	0.6724	0.4331	1.5056	0.2188	1.4956	0.0430	0.1715	1.9166	0.2001	0.4047	0.6797	0.6325	0.2694	8.6430
21	0.2552	0.2958	1.7225	0.6607	1.7388	1.3799	0.9916	4.2902	0.2861	0.2443	0.6823	0.6573	0.2687	13.4734
22	1.6134	1.6553	1.6131	1.6288	1.8139	1.3473	1.2868	2.1975	1.5798	1.6489	1.4619	1.4464	1.5286	20.8215
23	1.6134	1.6551	1.6131	1.6287	1.8138	1.3472	1.2868	2.1976	1.5798	1.6487	1.4619	1.4464	1.5285	20.8210
24	1.6134	1.6553	1.6131	1.6287	1.8138	1.3472	1.2868	2.1977	1.5798	1.6487	1.4619	1.4464	1.5286	20.8212
25	1.6134	1.6553	1.6131	1.6287	1.8138	1.3472	1.2868	2.1977	1.5798	1.6487	1.4619	1.4464	1.5286	20.8212
32	2.2710	1.4504	0.3499	1.4461	0.4194	1.3267	1.1236	0.9124	1.7685	1.3139	0.7859	0.8188	1.3417	15.3282

จุฬาลงกรณ์มหาวิทยาลัย

Table C.3: IAE Results of Pressure Deviation for the Process Stream

Stream	V1	V2	V3	V4	V5	V6	V7	V8	70	Q-80	Q-81	Q-82	Q-83	Sum IAE
1	1.7665	0.5593	0.2619	0.3211	0.1690	0.3060	0.4018	0.1670	0.5301	0.6033	0.6333	0.5825	0.6095	6.9112
2	1.7665	0.5593	0.2619	0.3211	0.1690	0.3060	0.4018	0.1670	0.5301	0.6033	0.6333	0.5825	0.6095	6.9112
3	1.7665	0.5593	0.2619	0.3211	0.1690	0.3060	0.4018	0.1670	0.5301	0.6033	0.6333	0.5825	0.6095	6.9112
4	1.7832	0.6894	0.3238	0.3972	0.2093	0.3788	0.4974	0.2066	0.6555	0.7584	0.7837	0.7208	0.7522	8.1564
5	1.8012	0.8378	0.3934	0.4826	0.2542	0.4599	0.6041	0.2510	0.7964	0.8770	0.9521	0.8756	0.9141	9.4992
6	1.8012	0.8378	0.3934	0.4826	0.2542	0.4599	0.6041	0.2510	0.7964	0.8770	0.9521	0.8756	0.9141	9.4992
7	1.8012	0.8378	0.3934	0.4826	0.2542	0.4599	0.6041	0.2510	0.7964	0.8770	0.9521	0.8756	0.9141	9.4992
8	1.8012	0.8378	0.3934	0.4826	0.2542	0.4599	0.6041	0.2510	0.7964	0.8770	0.9521	0.8756	0.9141	9.4992
9	1.8012	0.8378	0.3934	0.4826	0.2542	0.4599	0.6041	0.2510	0.7964	0.8770	0.9521	0.8756	0.9141	9.4992
10	1.8191	0.9571	0.4525	0.5637	0.2928	0.6105	0.6637	0.2875	0.9351	0.9787	1.0314	1.0317	1.0769	10.7006
11	1.8393	1.0989	0.5215	0.6593	0.3374	0.7955	0.7290	0.3299	1.0999	1.0958	1.1155	1.2164	1.1910	12.0293
12	1.8393	1.0989	0.5215	0.6593	0.3374	0.7955	0.7290	0.3299	1.0999	1.0958	1.1155	1.2164	1.1910	12.0293
13	1.8393	1.0989	0.5215	0.6593	0.3374	0.7955	0.7290	0.3299	1.0999	1.0958	1.1155	1.2164	1.1910	12.0293
14	1.8393	1.0989	0.5215	0.6593	0.3374	0.7955	0.7290	0.3299	1.0999	1.0958	1.1155	1.2164	1.1910	12.0293
15	1.8393	1.0989	0.5215	0.6593	0.3374	0.7955	0.7290	0.3299	1.0999	1.0958	1.1155	1.2164	1.1910	12.0293
16	0.0257	1.2754	2.5076	0.9050	4.7892	1.7441	1.6217	1.8028	1.0010	1.3165	1.5133	1.4529	1.1414	21.0966
17	0.1423	1.5459	1.1909	3.7086	0.7475	2.0026	1.7966	0.8806	1.9074	1.4430	1.1191	1.1471	1.4209	19.0526
18	0.1423	1.5459	1.1909	3.7086	0.7475	2.0026	1.7966	0.8806	1.9074	1.4430	1.1191	1.1471	1.4209	19.0526
18C	0.1068	1.5242	4.3304	2.8319	1.3345	1.9147	1.7295	1.1281	1.6105	1.4236	1.2135	1.2175	1.3562	21.7213
18D	0.0267	1.2713	2.4763	0.9039	4.8121	1.7464	1.6221	1.7820	1.0059	1.3110	1.5010	1.4427	1.1392	21.0407
19	0.1423	1.5459	1.1909	3.7086	0.7475	2.0026	1.7966	0.8806	1.9074	1.4430	1.1191	1.1471	1.4209	19.0526
20	0.0267	1.2713	2.4755	0.9040	4.8122	1.7461	1.6219	1.7807	1.0059	1.3109	1.5011	1.4424	1.1391	21.0379
21	0.0260	1.2739	2.5450	0.9090	3.5708	1.6103	1.4107	12.1196	0.7982	1.2181	1.6452	1.6885	1.1347	29.9500
22	0.0779	1.0923	1.1432	0.8183	0.7144	1.8538	1.6368	0.8314	1.2337	1.0650	0.9242	0.9617	1.0446	13.3974
23	0.0584	0.8884	0.9403	0.6547	0.5873	0.8168	1.5761	0.6684	0.9817	0.8712	0.7509	0.8083	0.8775	10.4801
24	0.0430	0.6657	0.7294	0.4956	0.4559	0.5218	0.7230	0.5143	0.7444	0.6786	0.6165	0.6229	0.6769	7.4879
25	0.0000	0.0000	0.0000	0.0000	0.0000	0.0000	0.0000	0.0000	0.0000	0.0000	0.0000	0.0000	0.0000	0.0000
32	0.0779	1.0923	1.1432	0.8183	0.7144	1.8538	1.6368	0.8314	1.2337	1.0650	0.9242	0.9617	1.0446	13.3974

จุฬาลงกรณ์มหาวิทยาลัย

Table C.4: IAE Results of Temperature Deviation for the Process Stream

Stream	V1	V2	V3	V4	V5	V6	V7	V8	70	Q-80	Q-81	Q-82	Q-83	Sum IAE
1	1.0986	0.0693	0.0161	0.0391	0.0234	0.0131	0.0315	0.0213	0.0582	0.0395	0.0233	0.0384	0.0632	1.5350
2	1.0987	0.0693	0.0161	0.0391	0.0234	0.0131	0.0315	0.0213	0.0582	0.0395	0.0233	0.0384	0.0632	1.5351
3	1.0987	0.0693	0.0161	0.0391	0.0234	0.0131	0.0315	0.0213	0.0582	0.0395	0.0233	0.0384	0.0632	1.5351
4	0.8958	0.9807	0.3377	0.7928	0.4939	0.2762	0.6617	0.4485	1.1934	2.4847	0.4893	0.8088	1.0232	10.8867
5	0.8463	1.2038	0.4108	0.9656	0.6010	0.3362	0.8052	0.5456	1.4511	2.2372	3.1078	0.9841	1.2520	14.7467
6	1.3601	2.0880	0.7035	0.3555	0.9936	4.1478	4.6877	1.1508	0.3805	1.5146	0.9000	0.5459	1.5897	20.4176
7	1.1095	0.9679	0.1836	0.4710	0.2577	2.3488	2.1106	0.3723	0.8699	1.7219	1.9405	0.7406	0.9100	14.0043
8	1.1101	0.9683	0.1836	0.4711	0.2578	2.3488	2.1107	0.3734	0.8700	1.7219	1.9405	0.7406	0.9106	14.0073
9	1.1101	0.9683	0.1836	0.4711	0.2578	2.3488	2.1107	0.3734	0.8700	1.7219	1.9405	0.7406	0.9106	14.0073
10	1.0147	0.6242	0.1051	0.8302	0.1556	1.9469	1.1308	0.1649	1.4642	0.8873	1.1208	1.1089	2.2858	12.8395
11	1.0469	0.5981	0.1496	0.8566	0.2194	1.7724	0.8925	0.1959	1.4917	0.7178	0.9123	2.3873	1.8623	13.1028
12	1.1057	1.1561	0.4426	0.3262	0.6350	1.1810	0.1607	0.4974	0.3419	0.6188	0.2839	0.0735	0.7487	7.5714
13	1.0561	0.9337	0.2457	0.5226	0.3479	0.1069	0.4542	0.3051	0.8210	0.6942	0.5512	0.9107	1.1622	8.1116
14	1.0649	0.9865	0.2449	0.5209	0.3479	0.1066	0.4547	0.2091	0.8215	0.7116	0.5444	0.8976	1.1871	8.0978
15	1.0649	0.9865	0.2449	0.5209	0.3479	0.1066	0.4547	0.2091	0.8215	0.7116	0.5444	0.8976	1.1871	8.0977
16	0.4852	1.1879	0.1075	1.1009	2.0990	0.1020	0.2263	0.4229	1.6597	0.6628	0.5732	0.9142	1.1647	10.7062
17	0.7764	0.6518	0.1018	2.0215	0.1509	0.2519	0.1850	0.2729	1.5294	0.3314	0.2516	0.3541	0.5409	7.4195
18	0.7560	0.6497	0.1116	1.9573	0.1655	0.2526	0.2015	0.2923	1.5311	0.3123	0.2514	0.3602	0.5248	7.3663
18C	0.7520	0.6493	1.0305	2.1660	0.5063	0.2523	0.2011	0.2969	1.6014	0.3108	0.2502	0.3585	0.5230	8.8983
18D	0.5377	0.5460	0.3254	1.1232	1.1297	0.2189	0.1581	0.6468	1.3410	0.2331	0.2144	0.3100	0.4329	7.2172
19	0.7559	0.6501	0.1103	1.9572	0.1654	0.2526	0.2014	0.2921	1.5311	0.3124	0.2514	0.3602	0.5250	7.3652
20	0.4223	0.6967	0.7631	0.6987	3.2042	0.1853	0.0631	1.0197	1.2832	0.2184	0.2573	0.3751	0.4679	9.6550
21	2.4739	3.5970	20.2848	5.9761	13.1876	0.5843	1.1452	16.8340	1.3106	5.3118	8.4440	12.3078	3.9909	95.4480
22	0.6013	0.5563	0.1834	0.9201	0.2276	0.2260	0.1414	0.4296	1.3296	0.2700	0.2788	0.4065	0.4796	6.0502
23	0.8800	2.0227	0.3069	0.6085	0.4712	6.0531	1.6470	0.4831	0.7468	1.8785	1.5758	0.3964	1.4521	18.5220
24	1.2060	1.2837	0.2628	0.2195	0.3743	1.2628	4.0088	0.4904	0.0806	0.7385	0.3695	0.0334	0.7577	11.0881
25	1.6088	2.3178	0.8280	1.0034	1.1739	1.0521	3.5191	1.3298	1.1281	1.2772	0.6646	0.4757	1.4451	17.8236
32	0.6636	0.5209	0.1005	1.0259	0.1589	0.2398	0.1732	0.2800	1.3560	0.2804	0.2725	0.3963	0.4764	5.9443

จุฬาลงกรณ์มหาวิทยาลัย

Table C.5: IAE Result of Composition, Level and Tray Temperature Deviation for the Process Stream

Stream	V1	V2	V3	V4	V5	V6	V7	V8	70	Q-80	Q-81	Q-82	Q-83	Sum IAE
E20	0.4271	0.2164	0.1463	0.1323	0.2583	0.0404	0.2091	0.0285	0.4234	0.1174	0.0712	0.0770	0.2033	2.3508
M20	0.4258	0.2751	0.1909	0.1448	0.3264	0.0402	0.2552	0.0275	0.4925	0.1426	0.0874	0.0934	0.2430	2.7447
E21	0.0782	1.5268	0.1621	0.9204	1.5525	1.5119	1.0965	1.3331	1.6779	1.4003	1.3960	1.3999	1.3409	15.3966
M21	3.0689	1.9817	3.5007	2.8025	1.8629	2.4074	2.4392	2.6108	1.4062	2.3397	2.4453	2.4297	2.2129	31.5079
Reb Level	0.7056	0.9470	0.1881	0.8228	1.4852	2.2664	1.8819	2.4483	1.3126	1.2356	1.7201	1.6767	1.1544	17.8449
LTS Level	0.4700	1.1791	0.4451	0.9852	0.3122	0.7075	1.0030	0.3320	0.8880	1.1418	1.0024	0.9769	1.1572	10.6003
VLS Level	1.8245	0.8738	2.3668	1.1920	1.2027	0.0261	0.1151	0.2197	0.7994	0.6226	0.2775	0.3464	0.6884	10.5549
Tray Temp														
1	0.5711	0.2977	0.0961	0.3353	0.3245	0.2043	0.0271	0.0343	0.6908	0.0940	0.0632	0.0412	0.1280	2.9075
2	0.4355	0.3691	0.1821	0.2868	0.3763	0.1639	0.0286	0.0402	0.7274	0.1006	0.0798	0.0523	0.1508	2.9934
3	0.4653	0.5297	0.1784	0.3143	0.3619	0.1184	0.0803	0.0302	0.8047	0.2081	0.1153	0.0766	0.2564	3.5397
4	0.4500	0.5389	0.1985	0.3028	0.3735	0.1110	0.0885	0.0356	0.8105	0.2105	0.1120	0.0494	0.2689	3.5500
5	0.4014	0.5700	0.2818	0.2608	0.4208	0.0795	0.1227	0.0555	0.8350	0.2290	0.1048	0.0952	0.3200	3.7767
6	0.1810	0.6673	0.5849	0.4398	0.6011	0.0307	0.2354	0.0837	0.8879	0.3349	0.1098	0.6971	0.4828	5.3363
7	0.1405	0.7659	0.6875	0.5229	0.5988	0.1164	0.3132	0.1508	0.8088	0.3359	0.0700	0.7779	0.5629	5.8514
8	0.4824	1.0711	1.0208	0.8038	0.6358	0.4264	0.5937	0.4179	0.5252	0.5869	0.6299	1.0403	0.8279	9.0622
9	1.4188	1.5967	1.7581	1.5937	1.0228	1.1680	1.2683	1.1121	0.9120	1.2594	2.1852	1.6061	1.4046	18.3057
10	2.5700	2.1662	2.6361	2.5536	2.1561	2.9596	2.9046	3.0214	1.6530	2.7589	3.1951	2.6111	2.5274	33.7132
11	3.8840	2.4274	3.3757	3.5863	4.1284	5.6217	5.3375	6.0182	2.3446	4.8818	4.3350	3.9528	4.0703	53.9638

Note: **E20** is the ethane composition in stream 20, **M20** is the methane composition in stream 20, **E21** is the ethane composition in stream 21, **M21** is the methane composition in stream 21, **Reb Level** is the reboiler level, **LTS Level** is the low temperature separator level, **VLS Level** is the vapor-liquid separator level, **Tray Temp** is the tray temperature of demethanizer tower

VITA

Mr.Uthai Gayapan was born in Songkhla, Thailand on January 1, 1984. He graduated Bachelor Degree in department of Chemical Engineering from Prince of Songkla University in 2006. After that he studied for master degree in Chemical Engineering and joined Control and Systems Engineering research group at Chulalongkorn University in 2007.



ศูนย์วิทยทรัพยากร
จุฬาลงกรณ์มหาวิทยาลัย