

CHAPTER II

EXPERIMENTAL

The synthesis and characterization procedure of perovskite oxide are described as below:

2.1 Chemicals

The chemicals listed in Table 2.1 were used without further purification.

Table 2.1 Reagents for synthesis of perovskites

Reagents	Formula Weight	Purity%	Company
Ba(CH ₃ COO) ₂	255.43	99.0	Fluka
Sr(NO ₃) ₂	211.63	99.0	Fluka
Fe(NO ₃) ₃ ·9H ₂ O	404.00	98.0	Riedel-deHaën
Co(CH ₃ COO) ₂	249.09	99	Fluka
Co(NO ₃) ₂ ·6H ₂ O	291.03	98.0	Fluka
Ni(NO ₃) ₂ ·6H ₂ O	290.79	98.0	Wako
Pr(NO ₃) ₃ ·6H ₂ O	435.01	99.9	Aldrich
La(NO ₃) ₃ ·6H ₂ O	433.01	99.0	Fluka
Mg(NO ₃) ₂ ·6H ₂ O	256.41	99.0	Fluka
Ga(NO ₃) ₃ ·xH ₂ O	255.74	99.9	Aldrich
C ₂ H ₅ NO ₂	75.07	99	Fluka
C ₁₄ H ₂₃ N ₃ O ₁₀	393.35	99	Fluka
C ₂ H ₆ O ₂	62.07	99.5	Fluka
C ₆ H ₈ O ₇	192.13	99.5	Riedel-deHaën
NH ₃ H ₂ O	35.05	25	Merck
C ₂ H ₅ OH	46.07	30	Merck

Table 2.2 The components of all samples

Components	Abbreviation
$Ba_{0.5}Sr_{0.5}Co_{0.8}Fe_{0.2}O_{3-\delta}$	BSCF
$PrSrCoO_4$	PSC
$PrSrNiO_4$	PSN
$La_{0.7}Sr_{0.3}Ga_{0.7}Fe_{0.2}Mg_{0.1}O_{3-\delta}$	LSGFM
$La_{0.8}Sr_{0.2}Ga_{0.8}Mg_{0.15}Co_{0.05}O_{3-\delta}$	LSGCM

Table 2.3 Chelating agents for synthesis of perovskites

Chelating agents	Abbreviation	Chelating : Metal ions
Citric Acid	MC	2:1
Glycine	G	2:1
Diethylenetriaminepentaacetic Acid	H ₅ DTPA	0.57:1
Citric Acid + Glycine	GC	2:1, 2:1
Ethylene glycol + Citric Acid	EC	20:1, 2:1

Table 2.4 Abbreviation of perovskites were synthesized by sol gel method

Sol gel method		
Components	Chelating agents	Abbreviation
$Ba_{0.5}Sr_{0.5}Co_{0.8}Fe_{0.2}O_{3-\delta}$	Citric Acid	S-BSCF-MC
	Glycine	S-BSCF-G
	Diethylenetriaminepentaacetic Acid	S-BSCF-H ₅
	Citric Acid + Glycine	S-BSCF-GC
	Ethylene glycol + Citric Acid	S-BSCF-EC
$PrSrCoO_4$	Citric Acid	S-PSC-MC
	Glycine	S-PSC-G
	Diethylenetriaminepentaacetic Acid	S-PSC-H ₅
	Citric Acid + Glycine	S-PSC-GC
	Ethylene glycol + Citric Acid	S-PSC-EC
$PrSrNiO_4$	Citric Acid	S-PSN-MC
	Glycine	S-PSN-G
	Diethylenetriaminepentaacetic Acid	S-PSN-H ₅
	Citric Acid + Glycine	S-PSN-GC
	Ethylene glycol + Citric Acid	S-PSN-EC

2.2 Synthesis of perovskite powder by sol gel method

Powders of perovskites oxides in Table 2.4 were prepared by sol-gel method. Stoichiometric amounts of corresponding high purity metal nitrates and acetates (based on 3 g. of perovskite powder) were partially dissolved in 10 ml D.I. water. Then various chelating agents (Table 2.3) were added with stirring at a ratio of chelate to metal ions following by Table 2.3. Then metal solution was stirred for 3 hours at room temperature. The mixture solution was titrated with $NH_3.H_2O$ at the controlled rate of 2-3 ml/min. The pH value of the solution was adjusted to ~9.

The combustion of the homogeneous solution was carried out on a hot plate at around 100-200°C for 1.5 hours. Then the water was evaporated until a sticky gel was obtained. Then it became a large swelling viscous mass and finally self ignited by NH_4NO_3 . The combustion lasted for about 10-20 seconds. The resulting powder was

preheated at 400°C for 2 hours then grind and sieved through 200 meshes (75 micron), subsequently the synthesized perovskite oxide was calcined in a Carbolite RHF 1600 muffle furnace in air to achieve phase purity and remove the residual carbon. The conditions which used for the calcination of the perovskite powders were shown in scheme 2.1.

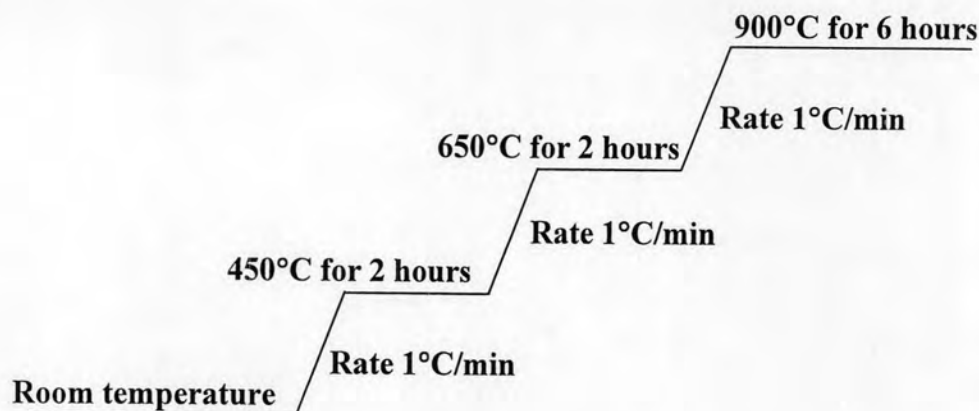

(a)

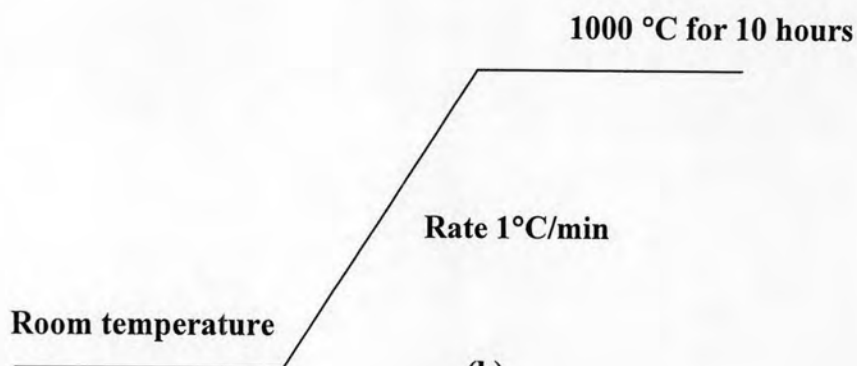

(b)

Scheme 2.1 The condition of calcination for $\text{Ba}_{0.5}\text{Sr}_{0.5}\text{Co}_{0.8}\text{Fe}_{0.2}\text{O}_{3-\delta}$, PrSrCoO_4 and PrSrNiO_4 (a), $\text{La}_{0.7}\text{Sr}_{0.3}\text{Ga}_{0.7}\text{Fe}_{0.2}\text{Mg}_{0.1}\text{O}_{3-\delta}$ and $\text{La}_{0.8}\text{Sr}_{0.2}\text{Ga}_{0.8}\text{Mg}_{0.15}\text{Co}_{0.05}\text{O}_{3-\delta}$ (b)

Table 2.5 List of the features of the perovskite compounds during preparation by sol gel method

Compounds	Solution color	Color changing during adjust pH to ~9	Color and appearance changed after heated at 100-200 °C for 1.5 hours	Material feature
S-BSCF-MC	red brown	red brown to dark brown solution	dark brown to dark brown gel	black powder
S-BSCF-G	red brown	red brown to dark brown slurry	dark brown slurry to dark brown gel	black powder
S-BSCF-H ₅	red brown	red brown to dark brown solution	dark brown to dark brown gel	black powder
S-BSCF-GC	red brown	red brown to dark brown solution	dark brown to dark brown gel	black powder
S-BSCF-EC	red brown	red brown to dark brown solution	dark brown to dark brown gel	black powder
S-PSC-MC	red	red to red brown solution	red brown to purple gel	black powder
S-PSC-G	red	red to red brown slurry	red brown slurry to purple gel	black powder
S-PSC-H ₅	red	red to red brown solution	red brown to purple gel	black powder
S-PSC-GC	red	red to red brown solution	red brown to purple gel	black powder
S-PSC-EC	red	red to red brown solution	red brown to purple gel	black powder
S-PSN-MC	green	green to dark blue solution	dark blue to dark blue gel	black powder
S-PSN-G	green	green to dark blue slurry	dark blue to dark blue gel	black powder
S-PSN-H ₅	green	green to dark blue solution	dark blue to dark blue gel	black powder

Table 2.5 List of the features of the perovskite compounds during preparation by sol gel method

Compounds	Solution color	Color changing during adjust pH to ~9	Color and appearance changed after heated at 100-200 °C for 1.5 hours	Material feature
S-PSN-GC	green	green to dark blue solution	dark blue to dark blue gel	black powder
S-PSN-EC	green	green to dark blue solution	dark blue to dark blue gel	black powder

Table 2.6 Abbreviation of perovskites were synthesized by hydrothermal method.

Hydrothermal method		
Components	Chelating agents	Abbreviation
$Ba_{0.5}Sr_{0.5}Co_{0.8}Fe_{0.2}O_{3-\delta}$	Citric Acid	H-BSCF-MC
	Glycine	H-BSCF-G
	Diethylenetriaminepentaacetic Acid	H-BSCF-H ₅
	Citric Acid + Glycine	H-BSCF-GC
	Ethylene glycol + Citric Acid	H-BSCF-EC
$La_{0.7}Sr_{0.3}Ga_{0.7}Fe_{0.2}Mg_{0.1}O_{3-\delta}$	Citric Acid	H-LSGFM-MC
	Glycine	H-LSGFM-G
	Diethylenetriaminepentaacetic Acid	H-LSGFM-H ₅
	Citric Acid + Glycine	H-LSGFM-GC
	Ethylene glycol + Citric Acid	H-LSGFM-EC
$La_{0.8}Sr_{0.2}Ga_{0.8}Mg_{0.15}Co_{0.05}O_{3-\delta}$	Citric Acid	H-LSGCM-MC
	Glycine	H-LSGCM-G
	Diethylenetriaminepentaacetic Acid	H-LSGCM-H ₅
	Citric Acid + Glycine	H-LSGCM-GC
	Ethylene glycol + Citric Acid	H-LSGCM-EC
$PrSrCoO_4$	Citric Acid	H-PSC-MC
	Glycine	H-PSC-G
	Diethylenetriaminepentaacetic Acid	H-PSC-H ₅
	Citric Acid + Glycine	H-PSC-GC
	Ethylene glycol + Citric Acid	H-PSC-EC
$PrSrNiO_4$	Citric Acid	H-PSN-MC
	Glycine	H-PSN-G
	Diethylenetriaminepentaacetic Acid	H-PSN-H ₅
	Citric Acid + Glycine	H-PSN-GC
	Ethylene glycol + Citric Acid	H-PSN-EC

2.3 Synthesis of perovskite powder by hydrothermal method

Powders of perovskites oxides in Table 2.5 were prepared by hydrothermal method. The salts of nitrates and acetates at the desired molar ratio (based on 3 g. of perovskite powder) were dissolved in deionized water. The amount of chelating agent was added following Table 2.3 with total metal ions. The pH of the mixture was adjusted to ~9 by ammonia solution (25%). The resulting solution was transferred into a Teflon lined stainless-steel autoclave and heated at 150°C for 20 hrs in the oven. Then the precursors were heated to 200-250°C on the hotplate. The spontaneous combustion occurred and the brown-black powder appeared. The precursors was preheated at 400°C for 2 hours then ground and sieved through 200 mesh (75 micron). The powder was calcined at 900°C for 6 hours, The condition of calcination was shown in scheme 2.1.

Table 2.7 List of the features of the perovskite compounds during preparation by hydrothermal method

Compounds	Solution color	Color changing during adjust pH to ~9	Color and appearance changed after placed autoclave in an oven at 150 °C for 20 hours	Material feature
H-BSCF-MC	red brown	red brown to dark brown solution	dark brown to dark brown with brown sediments	black powder
H-BSCF-G	red brown	red brown to dark brown slurry	dark brown to dark brown with brown sediments	black powder
H-BSCF-H ₅	red brown	red brown to dark brown solution	dark brown to dark brown with brown sediments	black powder
H-BSCF-GC	red brown	red brown to dark brown solution	dark brown to dark brown with brown sediments	black powder
H-BSCF-EC	red brown	red brown to dark brown solution	dark brown to dark brown with brown sediments	black powder
H-LSGFM-MC	yellow	yellow to dark yellow solution	yellow to green brown with brown sediments	brown powder
H-LSGFM-G	yellow	yellow to dark yellow slurry	yellow slurry to green brown with brown sediments	brown powder
H-LSGFM-H ₅	yellow	yellow to dark yellow solution	yellow to green brown with brown sediments	brown powder
H-LSGFM-GC	yellow	yellow to dark yellow solution	yellow to green brown with brown sediments	brown powder
H-LSGFM-EC	yellow	yellow to dark yellow solution	yellow s to green brown with brown sediments	brown powder
H-LSGCM-MC	light red	light red to light brown solution	light brown to brown with dark brown sediments	brown powder
H-LSGCM-G	light red	light red to light brown slurry	light brown to brown with dark brown sediments	brown powder

Table 2.7 List of the features of the perovskite compounds during preparation by hydrothermal method

Compounds	Solution color	Color changing during adjust pH to ~9	Color and appearance changed after placed autoclave in an oven at 150 °C for 20 hours	Material feature
H-LSGCM-H ₅	light red	light red to light brown solution	light brown to brown with dark brown sediments	brown powder
H-BSCF-MC	red brown	red brown to dark brown solution	dark brown to dark brown with brown sediments	black powder
H-BSCF-G	red brown	red brown to dark brown slurry	dark brown to dark brown with brown sediments	black powder
H-BSCF-H ₅	red brown	red brown to dark brown solution	dark brown to dark brown with brown sediments	black powder
H-BSCF-GC	red brown	red brown to dark brown solution	dark brown to dark brown with brown sediments	black powder
H-BSCF-EC	red brown	red brown to dark brown solution	dark brown to dark brown with brown sediments	black powder
H-LSGFM-MC	yellow	yellow to dark yellow solution	yellow to green brown with brown sediments	brown powder
H-LSGFM-G	yellow	yellow to dark yellow slurry	yellow slurry to green brown with brown sediments	brown powder
H-LSGFM-H ₅	yellow	yellow to dark yellow solution	yellow to green brown with brown sediments	brown powder
H-LSGFM-GC	yellow	yellow to dark yellow solution	yellow to green brown with brown sediments	brown powder
H-LSGFM-EC	yellow	yellow to dark yellow solution	yellow s to green brown with brown sediments	brown powder
H-LSGCM-MC	light red	light red to light brown solution	light brown to brown with dark brown sediments	brown powder

Table 2.7 List of the features of the perovskite compounds during preparation by hydrothermal method

Compounds	Solution color	Color changing during adjust pH to ~9	Color and appearance changed after placed autoclave in an oven at 150 °C for 20 hours	Material feature
H-LSGCM-G	light red	light red to light brown slurry	light brown to brown with dark brown sediments	brown powder
H-LSGCM-H ₅	light red	light red to light brown solution	light brown to brown with dark brown sediments	brown powder

2.4 Perovskite disc preparation

A KBr die was used for the shape-forming process, which includes loading, pressing and ejecting.

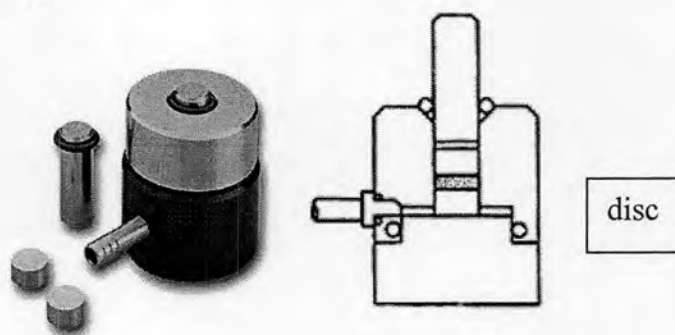

Figure 2.1 KBr die.

The disc shape of perovskites was formed by KBr die. The KBr die includes loading, pressing and ejecting. The very fine perovskite powder was loaded into the cavity, the plunger was brought to the surface of the powder gently for final leveling and then rotates for smooth surface. About 2 tons was applied on the plunger by the uniaxial pressing machine. At the beginning of pressing, the pressure was slowly applied to 2 tons for 20 minutes. The pressure was released and then the die was removed from the press. Then the assembly was held while the press until the pellet ejected.

The disc is around 1 mm thickness, 13 mm diameter from 1,700–1,800 mg of powder. Then the discs were generally sintered in air at 1,150–1,300°C for 6–10 hours, depending on the composition. Finally the sample was allowed to cool to room temperature.

2.5 The Sintering of the Perovskite Oxides

The perovskite membranes were generally sintered in air under different conditions, depending on the composition. The conditions used for the sintering of disc were set as follow:

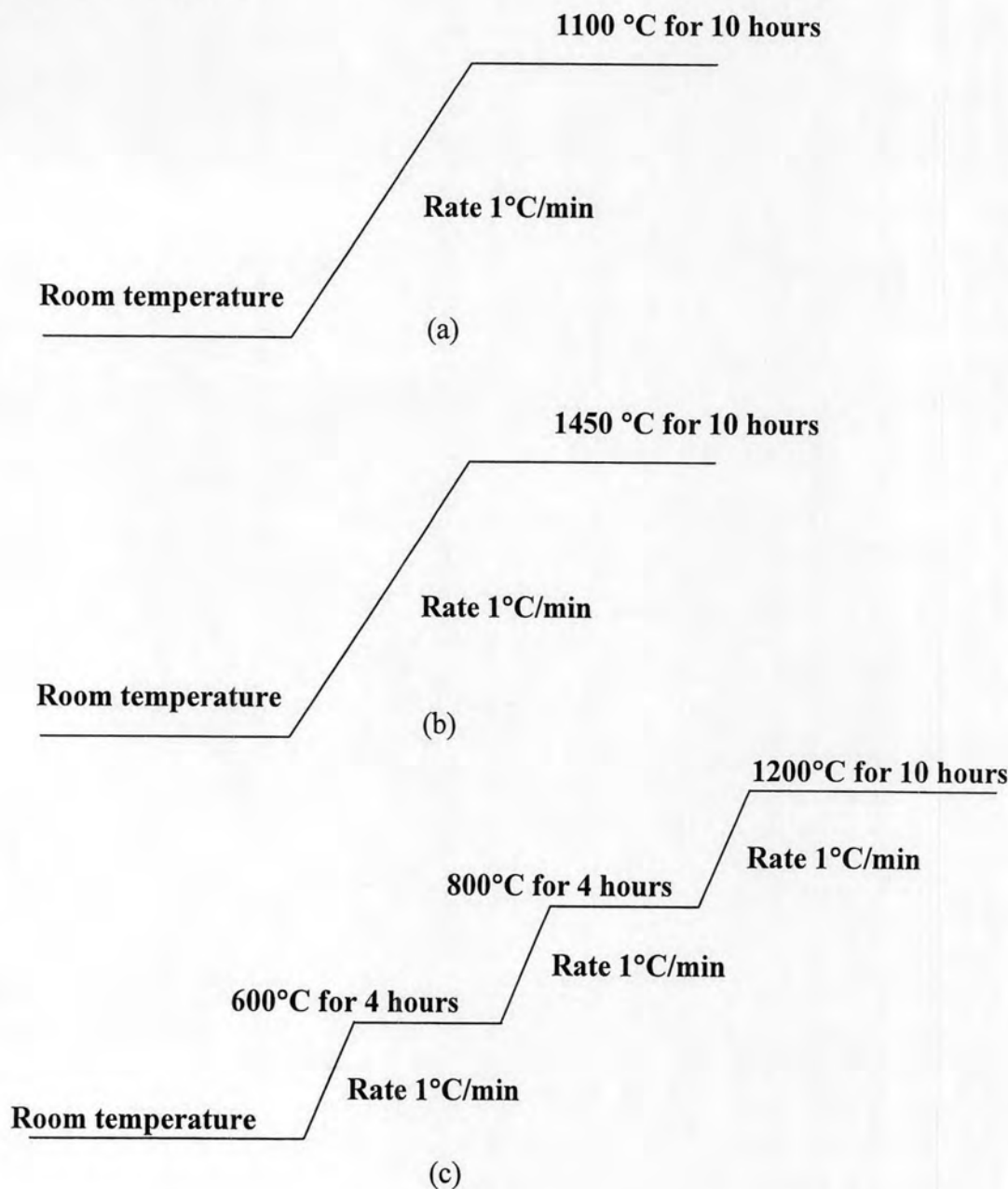

Scheme 2.2 The condition of sintering process of $\text{Ba}_{0.5}\text{Sr}_{0.5}\text{Co}_{0.8}\text{Fe}_{0.2}\text{O}_{3-\delta}$ (a), $\text{La}_{0.7}\text{Sr}_{0.3}\text{Ga}_{0.7}\text{Fe}_{0.2}\text{Mg}_{0.1}\text{O}_{3-\delta}$ and $\text{La}_{0.8}\text{Sr}_{0.2}\text{Ga}_{0.8}\text{Mg}_{0.15}\text{Co}_{0.05}\text{O}_{3-\delta}$ (b), PrSrCoO_4 and PrSrNiO_4 (c).

2.6 Characterization of the perovskite oxides

2.6.1 X-ray diffractometry (XRD)

The crystal structure of perovskite oxides was determined by using Rigaku, DMAX 2002 Ultima Plus X-Ray powder diffractometer equipped with a monochromator and a Cu-target X-ray tube (40 kV, 30 mA) and angles of 2θ ranged from 20-70 degree (step time 0.5 s., scan step 0.020°) at Department of Chemistry, Faculty of Science, Chulalongkorn University. Perovskites were characterized after the calcination steps by XRD.

2.6.2 Scanning electron microscopy (SEM)

The morphology of the disks was carried out using a JEOL JSM-5800LV scanning electron microscopy, Oxford Instrument (Link ISIS series 300) at Faculty of Science, Chulalongkorn University. This instrument uses X-rays or electrons scattered back from the surface “illuminated” by a restored electron beam to generate an image with remarkable three-dimensional qualities.

2.6.3 Electrical conductivity measurement

The electrical conductivity of perovskite oxide was investigated by DC-4 probe technique. All of disc samples (after sintered at 1100°C for 10 h) were cut to bar (about 12 mm in length, 5 mm in width and 1.5 mm in thickness). Four Pt wires were wrapped around each bar and bonded to the sample using Pt paste. The samples were heated to 950°C for 10 min with the heating rate of $5^\circ\text{C}/\text{min}$ to sinter the conducting paste. The conductivity measurements were performed in a tube furnace with an alumina tube using Pt wires to connect the wires on the sample in the hot zone. These wires were then fed through the end cap of the tube. Four-point DC electrical conductivity measurements were performed by sending a current (0.1 to 200 mA) through the wires at the ends of the sample and then measuring the voltage drop across and two middle wires. The electrical conductivity measurement from room temperature to 800°C were collected by potentiostat/galvanostat (Autolab PG100).

2.6.4 Dilatometer

The disc samples (after sintered at 1100°C for 10 h) were cut to bar (about 12 mm in length, 5 mm in width and 1.5 mm in thickness). The thermal expansion coefficients were measured from room temperature to 800°C in air with a heating rate of 10 K/min by dilatometer (NETZSCH DIL 402C) from Department of Materials Science, Faculty of Science, Chulalongkorn University.