



โครงการ

การเรียนการสอนเพื่อเสริมประสบการณ์

ชื่อโครงการ การวิเคราะห์สมบัติของฟิล์มบางวานาเดียมไดออกไซด์ใกล้สภาวะเปลี่ยนเฟสโลหะ-สารกึ่งตัวนำ โดยวิธีสเปกโทรสโกปีในช่วงอัลตราไวโอเล็ตถึงอินฟราเรด
UV-Vis-IR spectroscopy on VO₂ thin film near the metal-semiconductor transition

ชื่อหนังสือ นายชนันท์ แก้วสุขศรี **เลขประจำตัว** 5933426423

ภาควิชา ฟิสิกส์

ปี 2562

การศึกษา

คณะวิทยาศาสตร์ จุฬาลงกรณ์มหาวิทยาลัย

UV-Vis-IR spectroscopy on VO₂ thin film near the metal-semiconductor transition

A senior project presented to the
Faculty of Science
Chulalongkorn University

in fulfillment of the requirements for the Degree of Bachelor of Science
(Department of Physics)

By

Thanat Kaewsuksri

May 2020

Project title UV-Vis-IR spectroscopy on VO₂ thin film near the metal-semiconductor transition

Name Mr. Thanat Kaewsuksri

Project advisor Dr. Salinporn Kittiwatanakul

Department Physics

Academic year 2019

Accepted by the Department of Physics, Faculty of Science, Chulalongkorn University is
Partial Fulfillment of the Requirement for the Bachelor's degree of science

Examination Committee



Dr. Somrit Wongmanerod

(Chairman of the Examination Committee)



Asst. Prof. Dr. Sojiphong Chatraphorn

(Examination Committee)



Dr. Salinporn Kittiwatanakul

(Project Advisor)

TABLE OF CONTENTS

Acknowledgement	iii
Abstract	iv
Figure captions	v
Table captions	viii
Chapter 1. Introduction	1
1.1. Motivation	1
1.2. Objectives	1
1.3. Expected outcome	2
1.3.1. Own benefits	2
1.3.2. Benefits to others	2
Chapter 2. Background and literature review	3
2.1. Nature of vanadium dioxide	3
2.1.1. Crystal structure	3
2.1.2. Electronic band structure	4
2.1.3. Photoinduced electronic phase transition	5

2.2. Optical properties of VO ₂	6
2.2.1. Transmittance and reflectance of VO ₂ thin film	6
2.2.2. Temperature dependent absorptance	7
2.2.3. The optical phase shift during MST	8
2.2.4. Effects of films thickness, substrate and films synthesis methods	9
2.3. Spectroscopy	11
2.3.1 UV-Vis spectroscopy	11
2.3.2. IR spectroscopy	12
Chapter 3. Experiment	13
3.1. Temperature dependent resistance	13
3.2. Mini hot plate calibration	15
3.3. UV-Vis-IR spectroscopy near the metal-semiconductor transition	18
Chapter 4. Results and discussion	24
4.1. Temperature dependent resistance	24
4.2. Mini hot plate calibration	25
4.3. UV-Vis-IR spectroscopy near the metal-semiconductor transition	27
Chapter 5. Conclusion	34
References	35

Acknowledgement

This senior project is a part of the senior project subject 2304499, department of physics, faculty of science, Chulalongkorn university and could have not completed without the supporting from many people. First, I would like to very appreciate to my advisor, Dr. Salinporn Kittiwatanakul, who always teaches, helps and supports me to accomplish this project. I would like to express my sincere gratitude to both of senior project committees including Asst. Prof. Dr. Sojiphong Chatraphorn, who gives me a basic UV-Vis-IR spectrophotometer training, and Dr. Somrit Wongmanerod for their intention and guidance to make this project completed. I would like to give a thankful to Chalermwut Chumnanchar, who provide me electrical devices necessary for this project, and research division, central instrument facility, Mahidol university who provide the UV-Vis-IR spectrophotometer and make the spectroscopy measurement possible. I am also grateful for financial support from department of physics, Chulalongkorn university. Finally, I would like to express my appreciation to my beloved family who support me all time.

Abstract

Vanadium dioxide (VO_2) undergoes a phase transition near the room temperature at 68°C . This transition results in abrupt changes in electrical conductivity and optical property (especially reflectance and transmittance in the infrared region), which can be useful in many applications of sensing and switching. However, there are very few studies focus on optical property of VO_2 near the transition temperature. This project studied optical reflection of VO_2 covering UV, visible light, and IR region at various temperatures (from 25°C to 100°C) which is necessary to understand the fundamental properties and the way to improve VO_2 thin film for optical devices. The temperature dependent resistance measurement shows that the VO_2 thin film has a transition at $73 \pm 5^\circ\text{C}$. The temperature dependent reflectance of VO_2 thin film was observed in region of 200 - 900 nm. At the phase transition, the change in reflection is obviously observed in region of 300 - 400 nm and 700 - 900 nm which result in the transition temperature in range of 65.5°C - 68.4°C and 64.9°C - 68.4°C , respectively. The transition temperatures extracted by optical method is less than those retrieved from electrical method. It is most likely due to the photoexcitation.

FIGURE CAPTIONS

- Fig. 2.1.1.** Crystallographic structures of vanadium dioxide (VO_2): (a) Tetragonal/rutile (R) above the transition temperature T_c , and (b) monoclinic M_1 below T_c , Large and small spheres denote vanadium (V) and (two different types of M_1) oxygen (O) atoms, respectively. [4]..... 3
- Fig. 2.1.2.** Schematic modification of the d-band structure of VO_2 on transition from the semiconducting (left) to the metallic phase (right). [7]..... 4
- Fig. 2.1.3.** Change in electrical resistivity with temperature in heating and cooling curve of 500 nm VO_2 film on a Si substrate with its native oxide. [8]..... 4
- Fig. 2.1.4.** Elementary steps of the photoinduced electronic phase transition: (1) Photoexcitation promotes electrons to the conduction band and leaves the holes in the valence band. (2) Intraband transition increase the screening of the Coulomb interaction and thereby close the band gap. (3) Thermalization of carriers within the energetic region of the former gap occurs slower than this band gap collapse. [15]..... 5
- Fig. 2.2.1.** Spectral transmittance (upper panels) and reflectance (lower panels) for a 50-nm-thick coating of VO_2 (left-hand panels) and for a layer being a dilute dispersion of VO_2 nanosphere, with an equivalent VO_2 thickness of 50 nm, in a medium characteristic of transparent glass and polymer..... 7
- Fig. 2.2.2.** The spectral absorbance of VO_2 changes as a function of temperature (from 24 to 90 °C) with arrow indicating increasing temperature. [22]..... 8
- Fig. 2.2.3.** (**left**) Measured phase shift on a laser beam at 800 nm in transmission through a VO_2 films undergoing phase transition (**right**) measured phase shift on a laser beam at 1310 nm in reflection from a VO_2 thin films undergoing phase transition. Red and blue curves are for heating and cooling, respectively. [9]..... 9
- Fig. 2.2.4.** Comparison of the extracted refractive indices (extracted real (n) and imaginary (K) parts of the complex refractive indices) of the VO_2 films in **Table.1.** in the insulating (top) and metallic (bottom) phase, by different (a,b) synthesis methods; (c,d) substrate; and (e,f) film thicknesses. Note that the comparisons we make here are between the four films in Table 1, and the results should not be interpreted as definitive for, e.g., differences between all sputtered and sol-gel-synthesized VO_2 films. [24]..... 10

Fig. 2.3.1.	Simplified schematic of a double beam UV-Vis spectrophotometer.[25]....	12
Fig. 3.1.	Temperature dependent resistance measurement set up.....	14
Fig. 3.2.1.	Schematic diagram of experiment set up.....	17
Fig. 3.2.2.	Thermocouples mounting on surface (left) and inside the mini hotplate (right)	17
Fig. 3.3.1.	Specular and diffuse reflection.....	18
Fig. 3.3.2.	Measurement of specular reflection.....	19
Fig. 3.3.3.	Specular reflectance measurement attachment and schematic diagram of optical path. [26].....	19
Fig. 3.3.4.	Integrating sphere attachment and schematic diagram of optical path. [26]..	20
Fig. 3.3.5.	(left) Schematic diagram of experiment set up (right) installation of temperature controlling system for spectrophotometer.....	21
Fig. 3.3.6.	Attachment of sample to the mini hot plate.....	22
Fig. 3.3.7.	Attachment of mini hot plate to the spectrophotometer.....	22
Fig. 4.1.1.	Temperature dependent resistance measurement result.....	24
Fig. 4.2.1.	The relation between temperature of mini hot plate; reference temperature (black plot) and surface temperature (red plot), and current.....	25
Fig. 4.2.2.	The relation between surface temperature and reference temperature.....	26
Fig. 4.3.1.	The reflectance of VO ₂ thin film in region of 200 to 1400 nm using specular reflectance mode at 27.2 °C	27
Fig. 4.3.2.	The reflectance of VO ₂ thin film in region of 200 to 900 nm at various temperature across the metal-semiconductor transition measured in specular reflectance mode	28

Fig. 4.3.3. The reflectance of VO₂ thin film in region of 300 – 400 nm **(a)** and 700 – 900 nm. **(b)**.....30

Fig. 4.3.4. The transition temperature of the sample retrieved from the minimum of first-derivative of reflectance in region of 300 – 400 nm **(A)** and 700 – 900 nm. **(B)**.....32

TABLE CAPTIONS

Table.1. List of samples characterized	9
---	---

Chapter 1. Introduction

1.1. Motivation

Vanadium dioxide (VO_2) is one of transition metal oxides that exhibits a metal-semiconductor transition (MST), where the optical and electrical properties are rapidly changed. There are many materials that have the transition, i.e. VO_2 (68 °C), NbO_2 (807 °C) [1], Ti_2O_3 (137 °C), and V_2O_3 (-123 °C)[2], but VO_2 is the only one that has MST near room temperature. Because the transition temperature of VO_2 is not very far from room temperature, it is easier to study its properties near the MST compared to other materials since it does not need a lot of energy to heat up or cryogenic system to cool down to reach the MST. However, there are very few studies of optical properties near the MST. Most of them mainly focus on optical properties far in the metallic phase (at about 100 °C) and far in the semiconductor phase (at about 30 °C). So the study of optical properties in VO_2 near the transition temperature is necessary to understand the fundamental properties of material and the way to improve VO_2 for optical devices.

1.2. Objectives

- 1) To enable temperature dependent measurement in many scientific equipment including UV-Vis-IR spectrophotometer.
- 2) To study the effect of temperature on the optical properties of VO_2 thin film.

1.3. Expected outcome

1.3.1. Own benefits

- 1) Student able to analyze the effect of temperature on optical properties and electrical conductivity of VO₂ thin film.

- 2) Student understand how UV-Vis-IR spectrophotometer works.

1.3.2. Benefits to Others

Benefit of mini hot plate enable temperature dependent measurement of other characterization technique such as AFM, Raman, etc.

Chapter 2. Background and Literature review

2.1. Nature of vanadium dioxide

Vanadium dioxide or VO_2 is an inorganic compound. VO_2 has a phase transition very close to room temperature (68 °C). Below the phase transition temperature, VO_2 is a monoclinic semiconductor. Above the phase transition temperature, VO_2 is a metal with rutile or tetragonal structure.[3] The phase transition in VO_2 causes dramatic changes in electrical and optical properties which are useful for many applications such as optical switches and memory devices.

2.1.1. Crystal structure

In the monoclinic phase, the V^{4+} ions form pairs along the c axis, leading to alternate short and long V-V distances of 2.65 Å and 3.12 Å; in comparison, in the rutile phase the V^{4+} ions are separated by a fixed distance of 2.96 Å. As a result, the number of V^{4+} ions in the crystallographic unit cell doubles from the rutile to the monoclinic phase.[2]

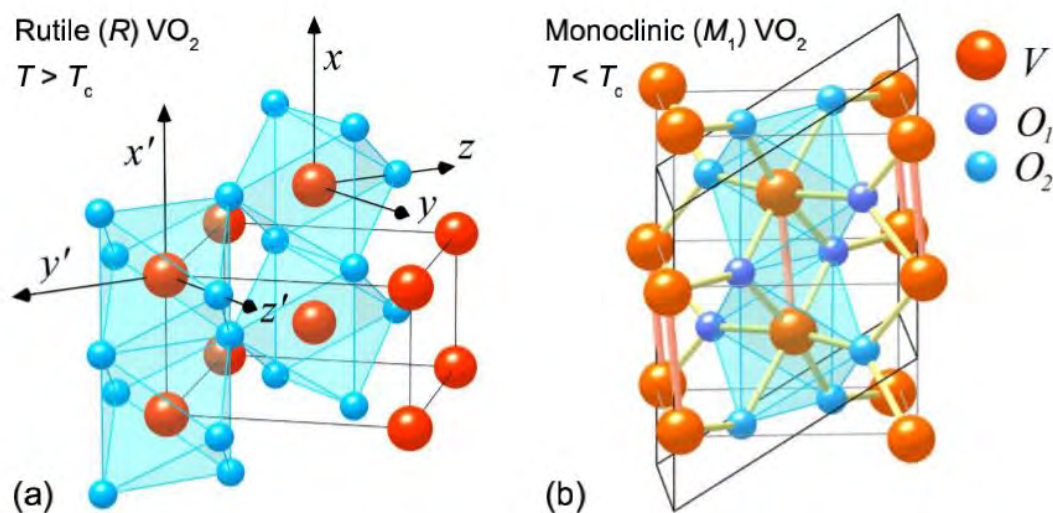

Fig. 2.1.1. Crystallographic structures of vanadium dioxide (VO_2): (a) Tetragonal/rutile (R) above the transition temperature T_c , and (b) monoclinic M_1 below T_c , Large and small spheres denote vanadium (V) and (two different types of M_1) oxygen (O) atoms, respectively. [4]

2.1.2. Electronic band structure

Vanadium atoms, electron configuration is $3d^3s^2$, have 4 electrons in the valence band and 1 electron in the conduction band. In the metallic phase, the bands close to the Fermi level are the $V3d$ bands, composed of a $d_{||}$ band orbitals of the O^{2-} atoms as shown in **Fig. 2.1.2. (left)**. In the semiconducting phase, the 3 $d_{||}$ band is split by the structural distortion (Peierls transition model) and electronic correlations (Mott transition model), while the $3d_{\pi}$ band is lifted above the Fermi level by the distortion of the V-O bonds as shown in **Fig. 2.1.2. (right)**. [5] The optical band gap of VO_2 in low-temperature monoclinic phase is about 0.7 eV. [6]

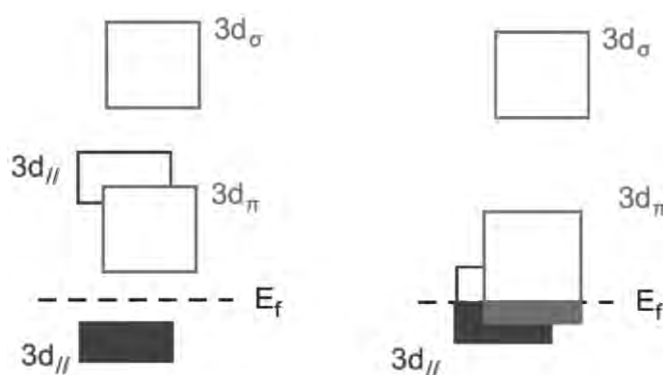

Fig. 2.1.2. Schematic modification of the d-band structure of VO_2 on transition from the semiconducting (left) to the metallic phase (right). [7]

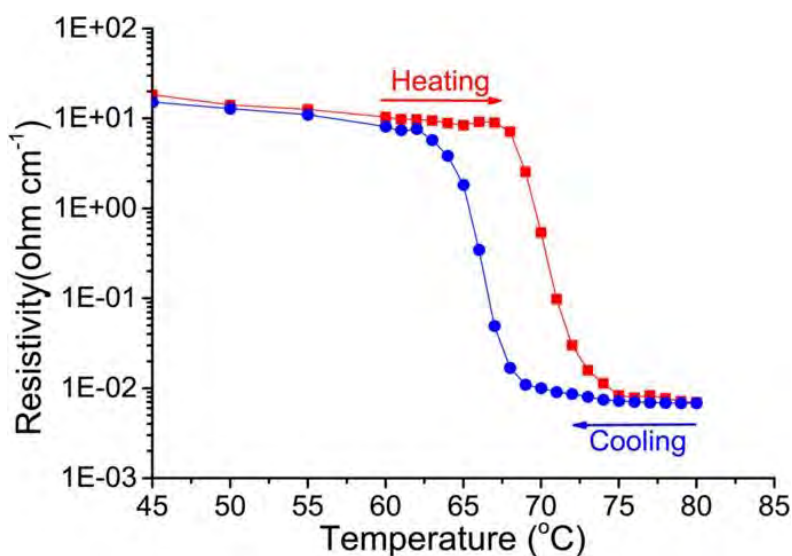

Fig. 2.1.3. Change in electrical resistivity with temperature in heating and cooling curve of 500 nm VO_2 film on a Si substrate with its native oxide. [8]

2.1.3. Photoinduced electronic phase transition

Optical excitation has been proven to be another method to drive the phase transition in VO₂. [9-10] In 2001, Cavalleri et al used femtosecond X-ray and visible-light pulse to study the structure and electron transition kinetics of the optically driven VO₂ metal-semiconductor transition. They found that laser pulse of sufficiently high fluence could trigger a sub-picosecond structural transition from the low temperature monoclinic phase to high temperature rutile phase. Additionally, they argued that the structural phase transition at the beginning may not be driven thermally for the insufficient heat flow triggering the transition. [11]

A large number of papers reported this ultrafast photoinduced response, and a non-thermal transiently metallic phase has been found in the time domain, which means that the characteristic time of gap-closing preceded the characteristic time of change in the lattice. [12-14]

As shown in **Fig. 2.1.4**, the optical excitation promotes electrons from the valence band to the conduction band, and then, the band gap collapse occurs due to the change in the screening of the Coulomb interaction through the free carriers.

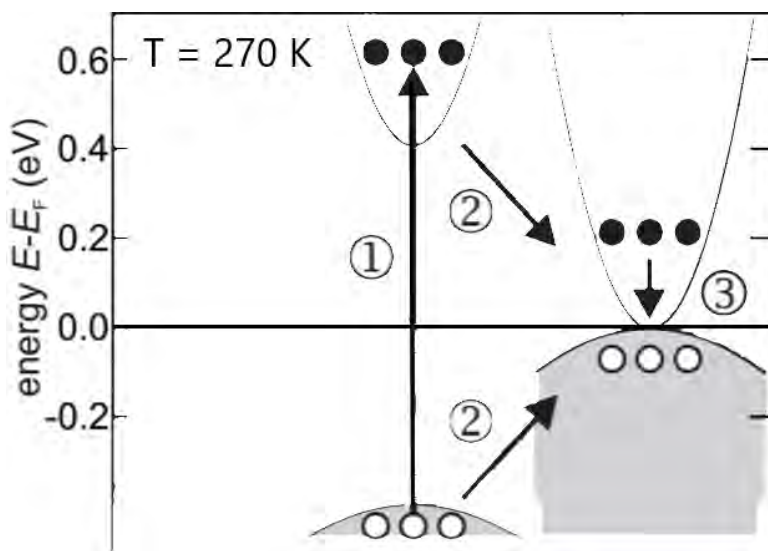

Fig. 2.1.4. Elementary steps of the photoinduced electronic phase transition: (1) Photoexcitation promotes electrons to the conduction band and leaves the holes in the valence band. (2) Intraband transition increase the screening of the Coulomb interaction and thereby close the band gap. (3) Thermalization of carriers within the energetic region of the former gap occurs slower than this band gap collapse. [15]

2.2. Optical properties of VO₂

MST causes the dramatic change in optical properties of VO₂. The dramatic change in optical properties of VO₂ has advanced a variety of applications, including switching and smart window.

2.2.1. Transmittance and reflectance of VO₂ thin film

The most significant optical properties of VO₂-based materials are illustrated in **Fig. 2.2.1**. Left-hand panels report the transmittance as a function of wavelength $T(\lambda)$ (upper) and reflectance as a function of wavelength $R(\lambda)$ (lower) for 50-nm-thick VO₂ coating in the wavelength range for solar irradiance, and it is apparent that $T(\lambda)$ is much larger in the semiconducting state than in the metallic states – i.e., below and above the transition temperature (about 68 °C), respectively – when $\lambda > 1 \mu\text{m}$. The difference in $T(\lambda)$ between low and high temperature grows for increasing wavelength. Obviously, this kind of variation in $T(\lambda)$ is the desired one, at least in principle, and a glazing with a tungsten carbide coating of VO₂ lets through more energy at low temperature than at high temperature. [16-20] **Fig. 2.2.1**. also shows that the corresponding curve for $R(\lambda)$ increases monotonically toward long wavelengths for the metallic state, which is to be expected for a free-electron-like material.

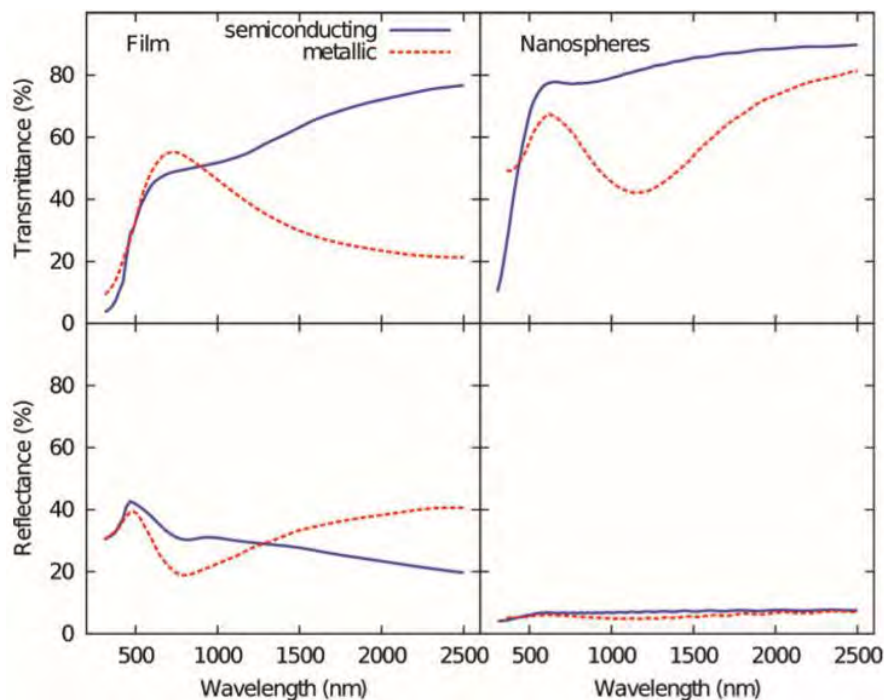

Fig. 2.2.1. Spectral transmittance (upper panels) and reflectance (lower panels) for a 50-nm-thick coating of VO₂ (left-hand panels) and for a layer being a dilute dispersion of VO₂ nanosphere, with an equivalent VO₂ thickness of 50 nm, in a medium characteristic of transparent glass and polymer.

2.2.2. The temperature dependent absorptance

As the temperature is increased there is almost no change in absorptance in the visible region, shown in **Fig. 2.2.2**, except a small increase in adsorptance from 440 to 520 nm (2.4 - 2.8 eV). This increased absorptance highlights the region of interband transitions between the oxygen 2p bands and the vanadium 3d bands with a Fermi level of approximately 2.5 eV. In the infrared region, there is an increase in the absorptance, which is characteristic of free-carrier absorption in VO₂. [21]

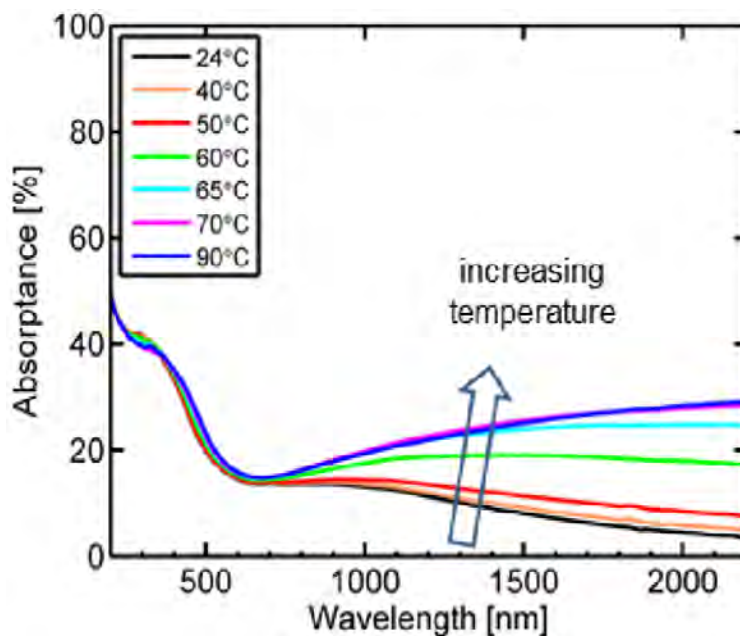

Fig. 2.2.2. The spectral absorbance of VO₂ changes as a function of temperature (from 24 to 90 °C) with arrow indicating increasing temperature. [22]

2.2.3. The optical phase shift during MST

The optical phase shift caused by the films was measured by counting fringe displacement as the VO₂ sample was heated. The resulting shifts in transmission at 800 nm and in reflection at 1310 nm are presented in **Fig. 2.2.2. (left)** and **(right)**, respectively. In transmission, the optical phase drops by a total -0.76 ± 0.1 rads. Between 25 and 80.1 °C (corresponding to ellipsometry measurements temperature) the shift is -0.46 ± 0.1 rads, close to the theoretically predicted several times to confirm reproducibility and consistency with theory. As observed in other optical and electrical properties of VO₂, there is hysteresis, as the heating and cooling cycles have different transition temperature. [23]

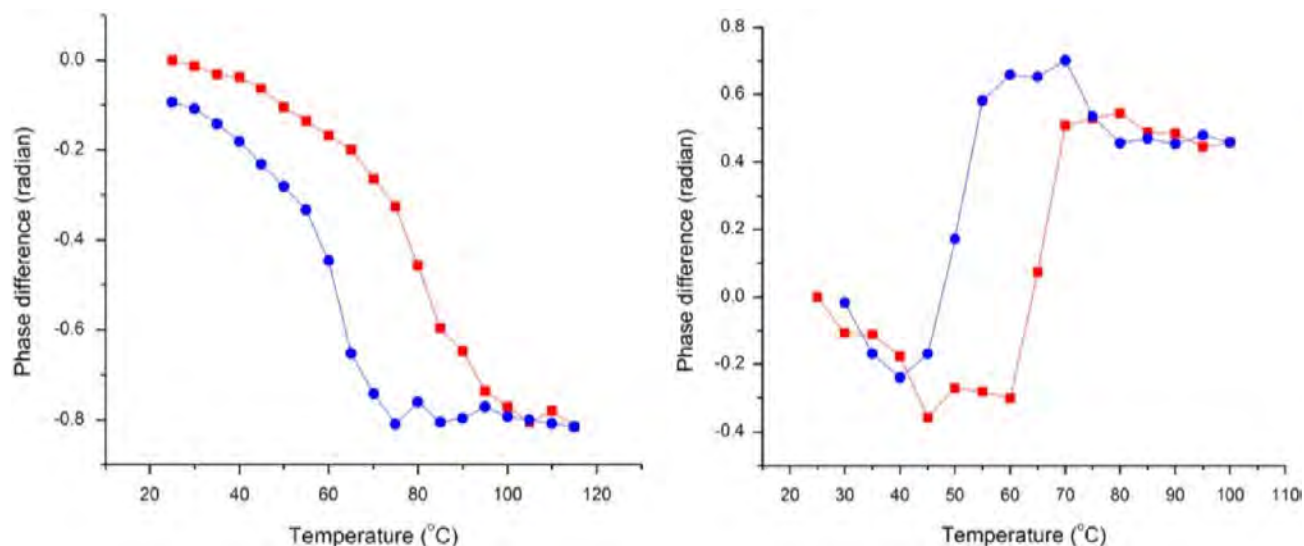

Fig. 2.2.3. (left) Measured phase shift on a laser beam at 800 nm in transmission through a VO₂ films undergoing phase transition **(right)** measured phase shift on a laser beam at 1310 nm in reflection from a VO₂ thin films undergoing phase transition. Red and blue curves are for heating and cooling, respectively. [9]

2.2.4. Effects of films thickness, substrate and films synthesis methods on their optical properties

Optical properties in VO₂ thin films depend on films thickness, substrate and synthesis method. There is a study of optical properties in VO₂ thin films across its MST for free-space wavelengths from 300 nm to 30 μm which vary on its thickness, substrate and synthesis method. There is a study of the complex refractive indices of various films (shown in **Table.1.**) by ellipsometry measurement. [24]

Table.1. List of samples characterized

	Thickness (nm)	Substrate	Synthesis method
Film 1	70 ± 9	Si + native oxide	Magnetron sputtering
Film 2	130 ± 17	Si + native oxide	Magnetron sputtering
Film 3	120 ± 12	Sapphire	Magnetron sputtering
Film 4	110 ± 5	Si + native oxide	Sol-gel

The thickness of the VO₂ films may affect its optical properties due to strain relaxation. To investigate this difference, VO₂ films on silicon (001) substrates with thickness of ~ 70 and ~ 130 nm (Films 1 and 2) using the same magnetron-sputtering recipe were prepared.

The substrate can significantly affect the film quality, in part due to the lattice mismatch at the substrate-films interface. To explore the role of the substrate on the optical properties, sputtered films of similar thickness (~120 and ~130 nm) but on different substrates: silicon (001) with a native oxide layer (Film 2), and c-plane-oriented sapphire (Film 3) were prepared.

The growth technique can also have large influence on the properties of VO₂. Two different synthesis methods of films (magnetron-sputtering (Film 2) and the sol-gel method (Film 4)) grown to a similar thickness (~110 and ~130 nm) on the same substrate (silicon with native oxide layer) were prepared for experiment to explore this influence.

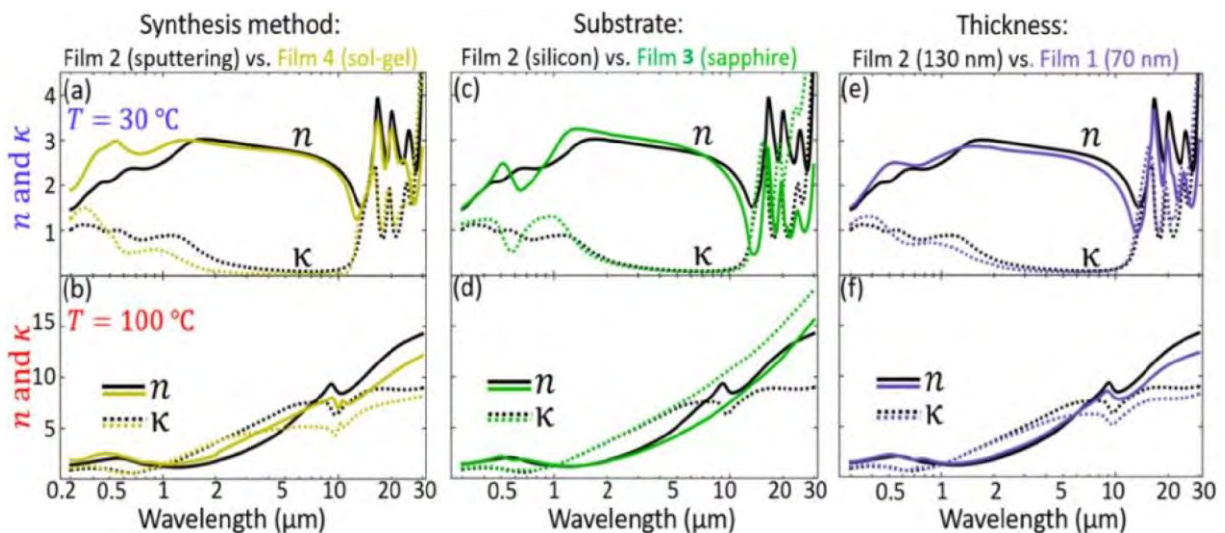

Fig. 2.2.4. Comparison of the extracted refractive indices (extracted real (n) and imaginary (κ) parts of the complex refractive indices) of the VO₂ films in **Table.1.** in the insulating (top) and metallic (bottom) phase, by different (a,b) synthesis methods; (c,d) substrate; and (e,f) film thicknesses. Note that the comparisons we make here are between the four films in Table 1, and the results should not be interpreted as definitive for, e.g., differences between all sputtered and sol-gel-synthesized VO₂ films. [24]

The experiment result show that there are very large differences in the optical properties at wavelengths below 2 μm , but relative consistency in the mid and far infrared, especially in the 2-11 μm region, which also corresponds to low optical losses for insulting phase.

2.3. Spectroscopy

Spectroscopy is a study of the properties of matter through its interaction with different frequency components of the electromagnetic spectrum. It is also a general methodology that can be adapted in many ways to extract the information needed (energies of electronic, vibrational, rotational states, structure and symmetry of the molecules).

2.3.1. UV-Vis spectroscopy

UV-Vis spectroscopy is a spectroscopy in ultraviolet-visible range. In this region of the electromagnetic spectrum, atoms and molecules undergo electronic transitions. Absorption spectroscopy is complementary to fluorescence spectroscopy, in that fluorescence deals with transitions from the excited state to the ground state, while absorption measures transitions from the ground state to the excited state.

The instrument used in UV-Vis spectroscopy is called a UV/Vis spectrophotometer. It measures the intensity of light passing through a sample (I), and compares it to the intensity of light before it passes through a sample (I_0). The ratio I/I_0 is called the transmittance, and is usually expressed as a percentage (%T). The absorbance, A , is based on the transmittance.

The UV-Vis spectrophotometer can also be configured to measure reflectance. In this case, the spectrophotometer measures the intensity of light reflected from a sample (I), and compares it to the intensity of light reflected from a reference material (I_0) (such as white tile). The ratio I/I_0 is called the reflectance, and is usually expressed as a percentage (%R). [25]

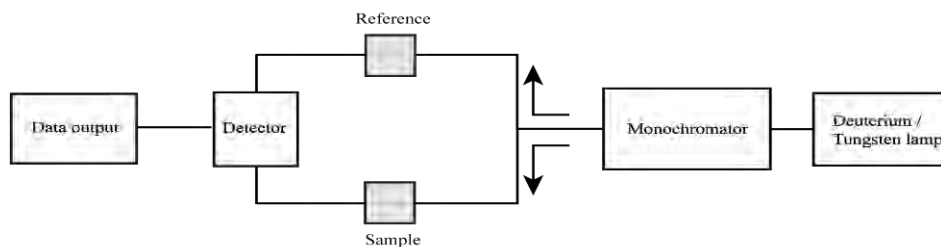

Fig. 2.3.1. Simplified schematic of a double beam UV-Vis spectrophotometer. [25]

2.3.2. IR spectroscopy

IR spectroscopy is a spectroscopy in infrared range. It can be used to identify and study chemical substances. Samples may be solid, liquid, or gas. The method or technique of infrared spectroscopy is conducted with an instrument called an infrared spectrometer (or spectrophotometer) to produce an infrared spectrum. Infrared spectroscopy exploits the fact that molecules absorb frequencies that are characteristic of their structure. These absorption occur at resonant frequencies, i.e. the frequency of the absorbed radiation matches the vibrational frequency. The energies are affected by the shape of the molecular potential energy surfaces, the masses of the atoms. [26]

Chapter 3. Experiment

This chapter describes the experiment description, experimental procedures and equipment necessary for the study of UV-Vis-IR spectroscopy on VO₂ thin film near metal-semiconductor phase transition. First, the VO₂ thin film sample was investigated by temperature dependent resistivity measurement. Then, the optical specular reflectance of the sample near the phase transition temperature was observed by spectrophotometer. To increase the temperature of the sample across the phase transition temperature, the sample was heated up by mini hot plate where the surface temperature and reference temperature were calibrated. The detail of each experiment is described below.

3.1. Temperature dependent resistance

The electrical properties of VO₂ thin film are related to its phase. Since phase transition can be driven by thermal energy so the electrical properties are changed by varying the temperature. Metal-semiconductor transition temperature (T_{MST}) is extracted from the derivative of the logarithm of the resistivity as a function of temperature, shown in equation 1. High-quality undoped VO₂ thin film should have T_{MST} near transition temperature of pure VO₂ (about 68 °C)

$$T_{MST} = \frac{T_{up} + T_{down}}{2} , \quad (1)$$

when T_{up} is temperature where $\frac{d(\log R_{up})}{dT}$ is at minimum, and T_{down} is temperature where $\frac{d(\log R_{down})}{dT}$ is at a minimum. R_{up} is the resistance from the heat up curve, and R_{down} is the resistance from the cool down curve. The VO₂ thin film sample used in this experiment is 100 nm VO₂/ c- Al₂O₃.

Equipment

- 1) Sanwa CD771 multimeter
- 2) Fisher Scientific 11-100-49SH hot plate
- 3) Clamp

Experimental procedures

- 1) Experiment set up is shown in **Fig. 3.1**.

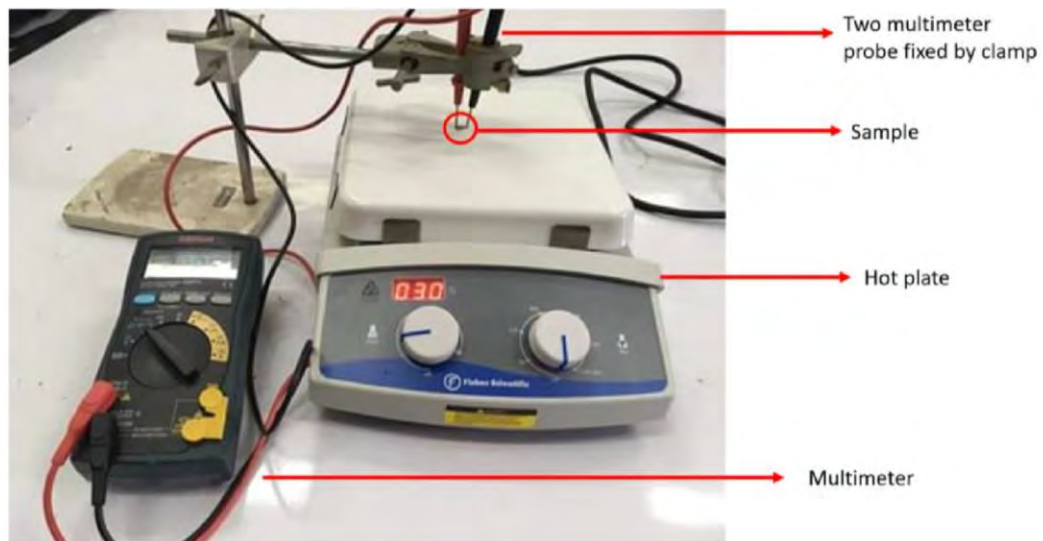

Fig. 3.1. Temperature dependent resistance measurement set up.

- 2) Use the multimeter to measure the resistance of the sample at the room temperature.

- 3) Heat up the sample by adjusting the hot plate.
- 4) At each heat up step, increase the temperature by 5 °C and wait at least 3 minutes then measure the resistance of the sample.
- 5) Vary the temperature from room temperature to 110 °C.
- 6) Cool down the sample by adjusting the hot plate.
- 7) At each cool down step, decrease the temperature by 5 °C and wait at least 3 minutes then measure the resistance of the sample. Cool down the sample until it reaches at the room temperature.
- 8) Determine the minimum of first-derivative of resistance for both heat up- and cool down curves.
- 9) Find T_{MST} of the sample by using the equation 1.

3.2. Mini hot plate calibration

The temperature controlling system consists of 3 parts: mini hot plate, power supply and thermometer. Mini hot plate is a heater made from mica sheet which nichrome wire is wound and covered by aluminium heat sink behaves like a resistor in electronic circuit of which power depends on electric current squared and resistivity. By assuming that resistivity slightly changes in range of 25 °C to 100 °C temperature and can be considered a constant. So the temperature of mini hot plate will be directly proportional to current squared. The temperature was varied by adjusting driven current from power supply.

Mini hot plate is serially connected with an ammeter and a power supply. Thermocouple was mounted to mini hot plate at two positions: inside the mini hot plate (as a reference temperature) and at the surface of mini hot plate where sample attached with. Under the assumption that the sample will have the temperature as the same as mini hot plate surface if the system is in thermal equilibrium by taking a long time. Power supply was used to control the current driven for mini hot plate. To calibrate the mini hot plate, the temperature at the surface and inside of mini hot plate was measured at each current.

Equipment

- 1) Variable DC voltage power supply
- 2) Sanwa CD771 multimeter
- 3) Mini hot plate
- 4) Heatsink silicone
- 5) Tenma 72-7715 thermometer
- 6) 2 pieces of k-type thermocouples

The experimental procedure

- 1) Experiment set up is shown in **Fig. 3.2.1**.

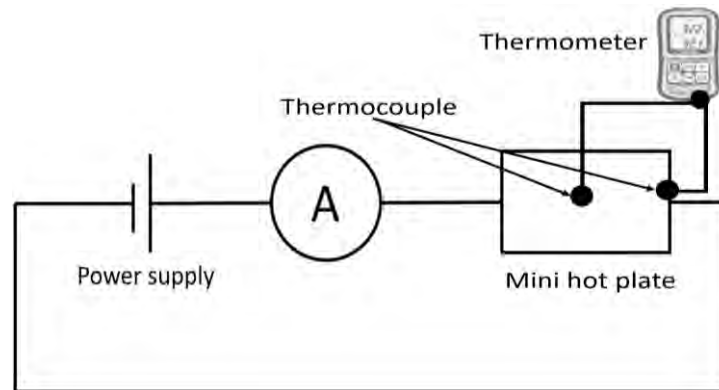

Fig.3.2.1. Schematic diagram of experiment set up.

- 2) Mount two thermocouples, connected to the thermometer, inside and on the surface of the mini hot plate. (see in **Fig. 3.2.2**.)

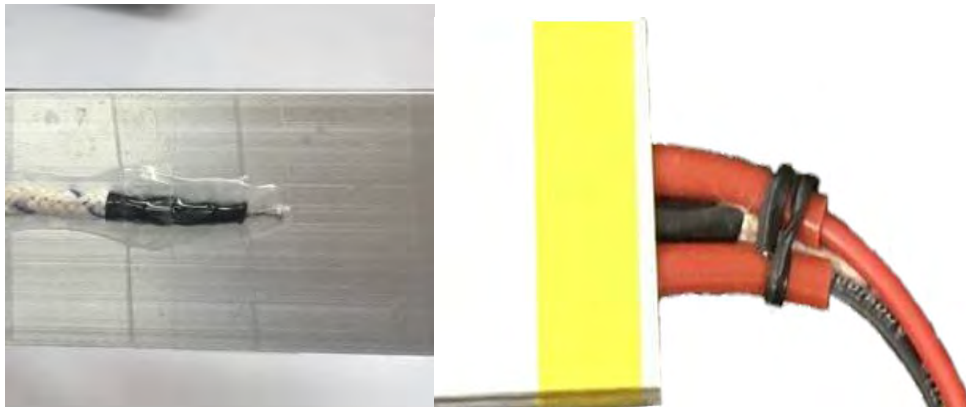

Fig. 3.2.2. Thermocouples mounting on surface (**left**) and inside the mini hotplate (**right**).

- 3) Increase the driven current for mini hot plate by adjusting the power supply then wait until the driven current and temperature of mini hot plate are stable.

- 4) Measure the driven current through mini hot plate and the temperature at reference point and at the surface of mini hot plate by thermometer.
- 5) Increase the driven current until the surface temperature of the mini hot plate reaches at 100 °C.

3.3. UV-Vis-IR spectroscopy near metal-semiconductor phase transition

Light cannot penetrate opaque (solid) samples and is reflected on the surface of the sample. As shown in **Fig. 3.3.1**, incident light reflected symmetrically with respect to the normal line is called “specular reflection” while incident light scattered in different directions is called “diffuse reflection”.

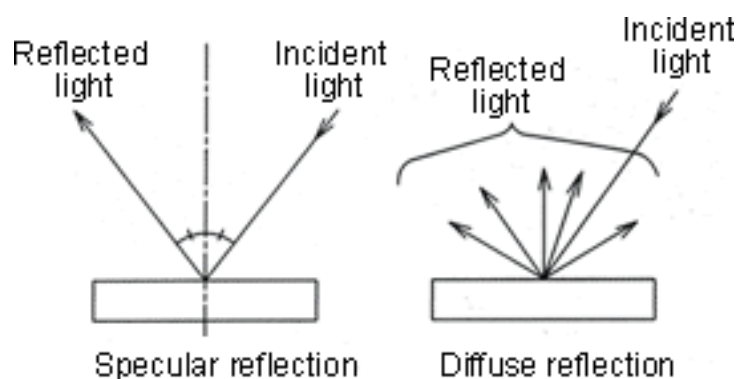

Fig. 3.3.1. Specular and diffuse reflection.

In this experiment, the specular reflectance of VO₂ thin films was observed by Shimadzu UV-2600 series spectrophotometer.

With relative specular reflectance measurement, the reflectance is calculated from the strength ratio after comparing the light reflected from the reference sample with the light reflected from the measurement sample. The reference sample used for reflectance measurement was a reflecting mirror.

As shown in the **Fig. 3.3.2**, the reflectance of the reference sample is taken to be 100 %, and the reflectance of the sample with respect to this reference sample is measured. This method is often applied to the examination of semiconductors, optical materials and films.

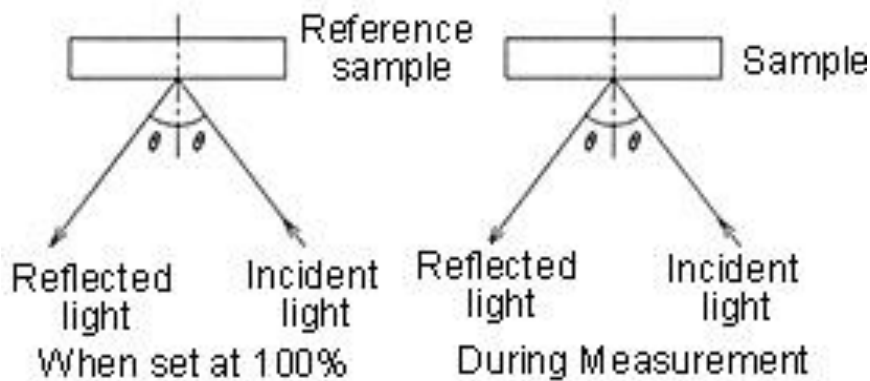

Fig. 3.3.2. Measurement of specular reflection.

For specular reflectance measurement, there are some accessories, which determine the angle of reflection and the region of spectroscopy wavelength, was used to equipped and the spectrophotometer; specular reflectance measurement attachment and integrating sphere attachment.

Specular reflectance measurement attachment

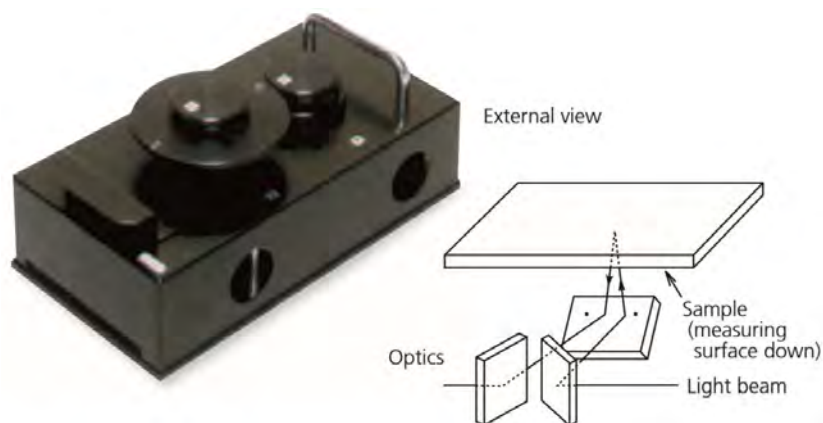

Fig. 3.3.3. Specular reflectance measurement attachment and schematic diagram of optical path. [27]

The technique of specular reflectance measurement is often applied to the evaluation of semiconductors, optical materials, multiple layers, etc. relative to a reference reflecting surface. The 5° incident angle minimizes the influence of polarized light. Thus, no polarizer is required for measurement, making the operation quite simple.[27] The specular reflectance measurement attachment provides the reflectance observation in region of 200 - 900 nm.

Integrating sphere attachment



Fig. 3.3.4. Integrating sphere attachment and schematic diagram of optical path. [27]

By combining the $0^\circ/8^\circ$ incidence angle integrating sphere, diffuse and specular reflectance measurements are possible without using any special attachments. The integrating sphere provides the reflectance measurement in region of 200 - 1400 nm. [27]

Since the integrating sphere attachment cannot operate under high temperature condition so the specular measurement attachment was used to observe the optical reflectance of the sample across the phase transition in region of wavelength of 200 - 900 nm.

Equipment

- 1) Variable DC voltage power supply
- 2) Sanwa CD771 multimeter Mini hot plate
- 3) Heatsink silicone
- 4) Tenma 72-7715 thermometer
- 5) K-type thermocouple
- 6) Insulating tape
- 7) Shimadzu UV-2600 series spectrophotometer

The experimental procedure

- 1) Experiment set up shown in **Fig. 3.3.5**.

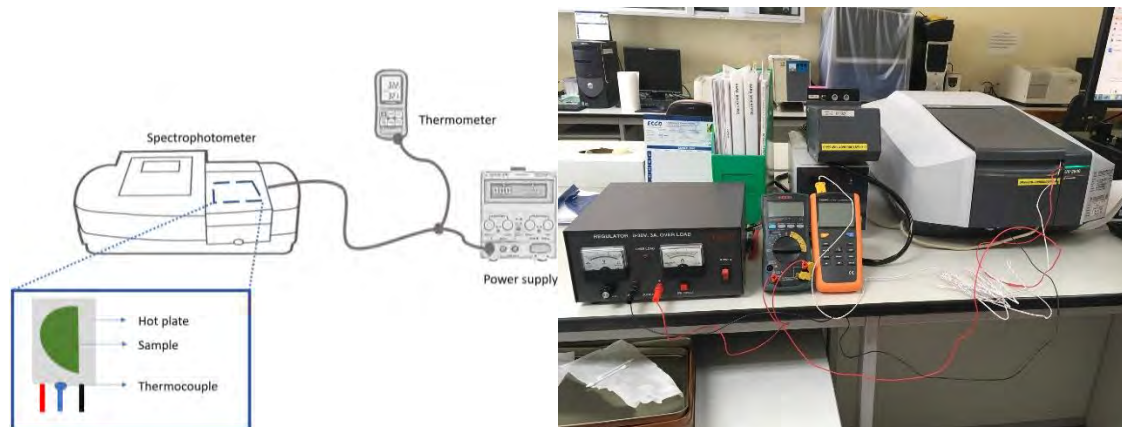

Fig.3.3.5. (left) Schematic diagram of experiment set up (right) installation of temperature controlling system for spectrophotometer.

- 2) Mount the thermocouple, connected to the thermometer, inside the mini hot plate. (see **Fig. 3.2.2. (right)**)
- 3) Attach the sample with the mini hot plate by heatsink silicone. (see **Fig. 3.3.6**)



Fig.3.3.6. Attachment of sample to the mini hot plate.

- 4) Secure the mini hot plate to the specular measurement attachment by insulating tape. (see **Fig. 3.3.7**)



Fig. 3.3.7. Attachment of mini hot plate to the spectrophotometer.

- 5) Set the parameter of spectrophotometer listed below, then do the baseline for specular reflection.

5.1 Measuring mode: specular reflection

5.2 Scan speed: medium

5.3 Sampling interval (nm): 1.0

5.4 Slit width (nm): 1.0

5.5 wavelength range (nm): 200 - 900

- 6) Measure the optical reflection of the sample at room temperature.
- 7) Heat up the sample by adjusting the power supply. Wait until the temperature of the mini hot plate is stable then measure the reflectance of the sample at each temperature from room temperature to 80 °C with the step of 5 - 10 °C.
- 8) Equip the integrating sphere for specular measurement, set the spectrophotometer parameter of wavelength range to 200 - 1400 nm then do the baseline.
- 9) Measure the reflectance of the sample in region of 200 - 1400 nm at room temperature for a reference.
- 10) Calculate the real temperature of the sample by calibration equation retrieved from experiment in section 3.1.
- 11) Analyze the result, find the reflectance of the sample at each temperature at certain wavelength.

Chapter 4. Result and Discussion

This chapter discusses the experiment results involving temperature dependent resistivity measurement, mini hot plate calibration and UV-Vis-IR spectroscopy near metal-semiconductor phase transition experiment. The phase transition temperature of the sample can be extracted from temperature dependent resistivity curve. The VO₂ thin film quality can be indicated by the phase transition temperature (high-quality films will have a phase transition temperature about 68 °C). To study the spectroscopy of VO₂ thin film near the phase transition temperature, the sample was heated up by mini hot plate and its reflectance was observed by spectrophotometer. However, the temperature of the sample cannot be directly measured during the reflectance observation by spectrophotometer so the real temperature will be obtained from mini hot plate calibration. The results of each region (UV-Vis-IR) as a function of temperature across the metal-semiconductor transition will be discussed.

4.1. Temperature dependent resistance

The result shows that electrical resistance of VO₂ thin film is decreasing when temperature is rising. An abrupt change in resistance can be observed across phase transition (shown in **Fig. 4.1.1.**), which can be used to determine the transition temperature of the VO₂ thin film.

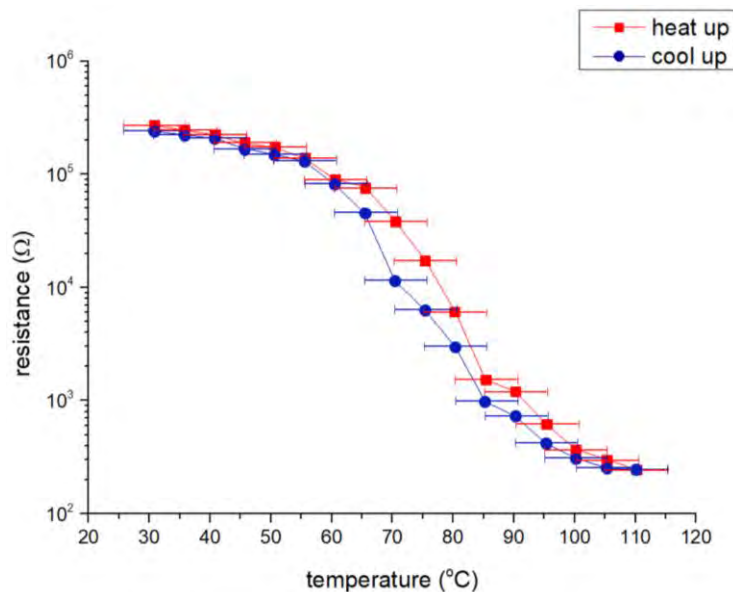

Fig. 4.1.1. Temperature dependent resistance measurement result.

Hysteresis loop was observed between heat-up and cool down branches of the resistance curves. The hysteresis is extended along the temperature axis. Hysteresis is intrinsic property of bulk VO₂; however, for thin film, it has been reported that this can be modified. The study of atomic force microscopy (AFM) of VO₂ films suggests that a fundamental change in the hysteresis loop shape affected by the grain distribution over phase transition temperature and grain size of VO₂ films [28].

Using the minimums of first-derivative of resistance as a function of temperature for both heat-up and cool-down curves, the result shows that the 100 nm VO₂/ c- Al₂O₃ sample has transition temperature at 73 ± 5 °C.

4.2. Mini hot plate calibration

The relation between temperature and current shown in **Fig. 4.2.1**. The plotted graph of temperature at the surface as function of reference temperature (temperature inside the mini hot plate) shown in **Fig. 4.2.2**.

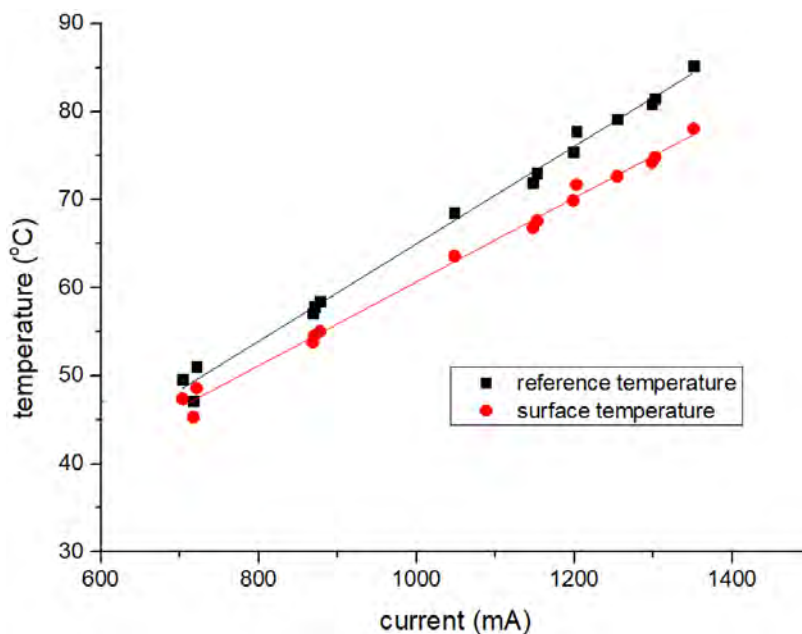

Fig. 4.2.1. The relation between temperature of mini hot plate; reference temperature (black plot) and surface temperature (red plot), and current.

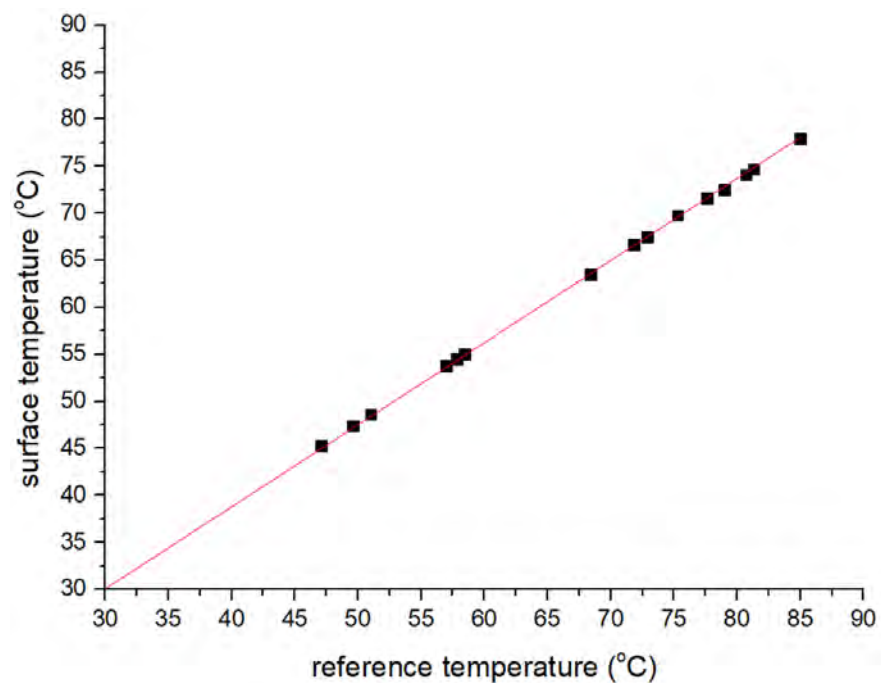

Fig. 4.2.2. The relation between surface temperature and reference temperature.

The temperature of the sample which attached to the mini hot plate surface will be approximate to the surface temperature of mini hot plate if the system takes a long enough time. However, the surface temperature of mini hot plate cannot be directly detected by thermometer when the optical reflectance of the heated sample was measured by spectrophotometer because the thermocouple on the surface may interrupt the optical path of the spectroscopy. Thus, the reference temperature was used to represent to temperature of the sample by the calibration equation. The calibration equation is retrieved from the relation between surface and reference temperature which is shown in Fig. 4.2.2.

4.3. UV-Vis-IR spectroscopy near metal-semiconductor phase transition

The Shimadzu UV-2600 series spectrophotometer used in this experiment can operate in range of 200 - 1400 nm. The reflectance measurement of VO₂ thin film at room temperature (about 27 °C) is shown in **Fig. 4.3.1**.

For sample heating, the spectrophotometer have to be equipped to specular reflectance mode which allows the spectrophotometer to operate under high temperature condition by using mini hot plate. However, the specular reflectance mode limits region of spectroscopy to 200 - 900 nm. The reflectance of VO₂ thin film in region of 200 to 900 nm at various temperatures are shown in **Fig. 4.3.2**.

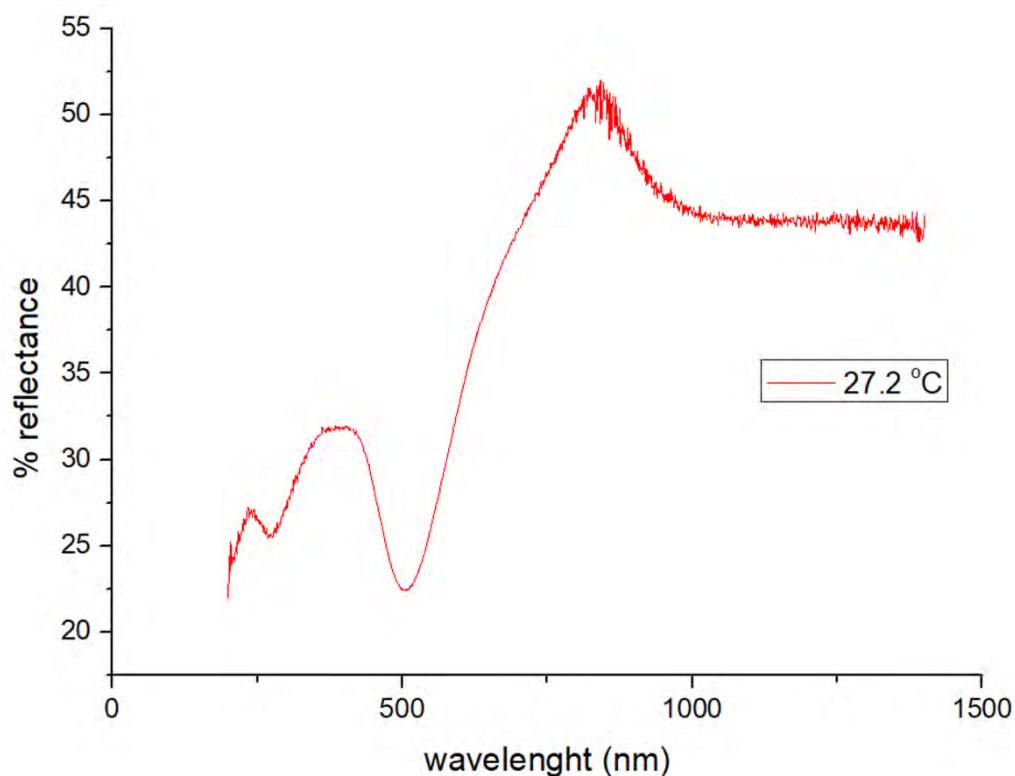

Fig. 4.3.1. The reflectance of VO₂ thin film in region of 200 to 1400 nm using specular reflectance mode at 27.2 °C.

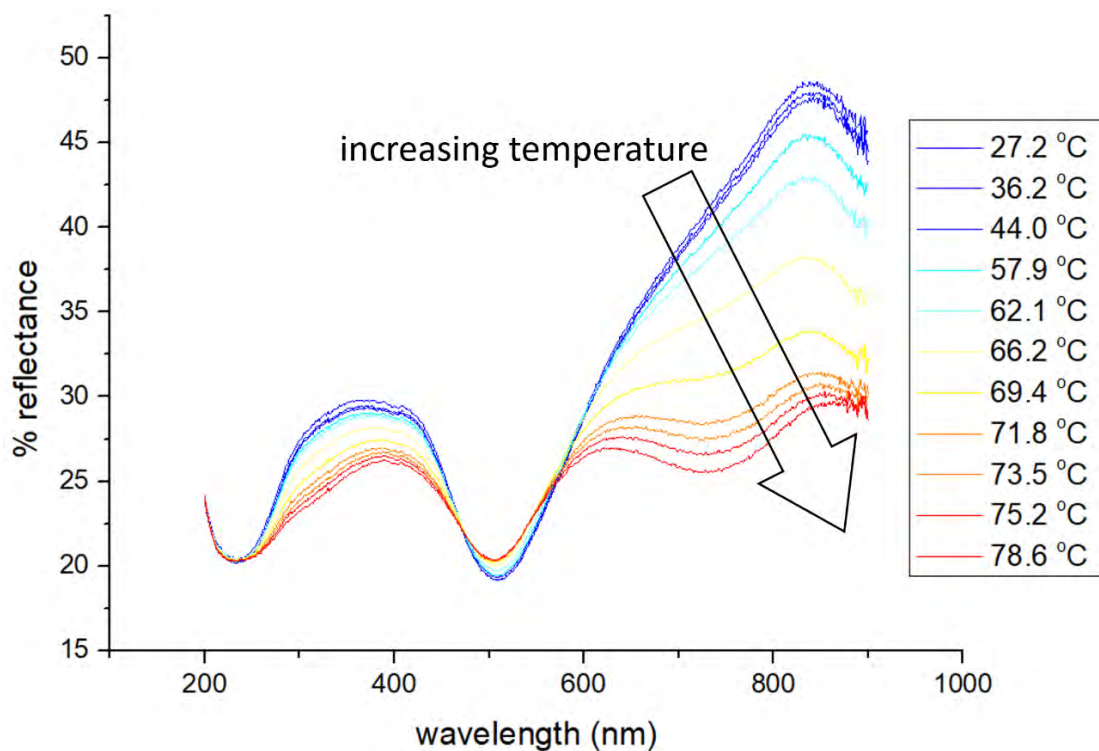

Fig. 4.3.2. The reflectance of VO₂ thin film in region of 200 to 900 nm at various temperature across the metal-semiconductor transition measured in specular reflectance mode.

The oscillation of reflectance of the sample varied by temperatures can be observed. The result shows that the magnitude of reflectance of the sample vary periodically with wavelengths. Multiple oscillations occur on the reflectance due to interferences among multiple reflected waves from boundary of air, thin film and substrate [29]. As the wavelength increase, oscillation period of these characteristic changes/increases. Thus, the reflectance characteristics of thin film are strongly dependent on the wavelength of spectrum and films thickness.

Focusing on the reflectance in region of infrared which is useful for VO₂ smart window applications, there is a decrease in reflectance when the temperature is increasing. However, due to the limitation of spectrophotometer used in this experiment, the infrared reflection can be detected only in partly region of infrared (700 - 900 nm). There are many studies on infrared reflection of VO₂ thin film indicate that the reflectance curve of metallic phase is increasing by the increasing wavelength while the reflectance curve of semiconductor phase is slightly decreasing. The wavelength which the semiconductor and metallic phase curves cross over at is more than 1000 nm and can be varied by the quality of the thin films and optical experimental parameters [16-20,22,30]. This result confirms that the VO₂ thin film does not block the infrared spectrum in region below 1000 nm even when it reaches the metallic phase.

From the **Fig. 4.3.2**, the rapid change in reflectance is obviously seen in region of 300 - 400 nm and 700 - 900 nm. To determine the transition temperature, the reflectance of VO₂ thin film is plotted as a function of temperature at various wavelengths. Some selected regions are shown in **Fig. 4.3.3**.

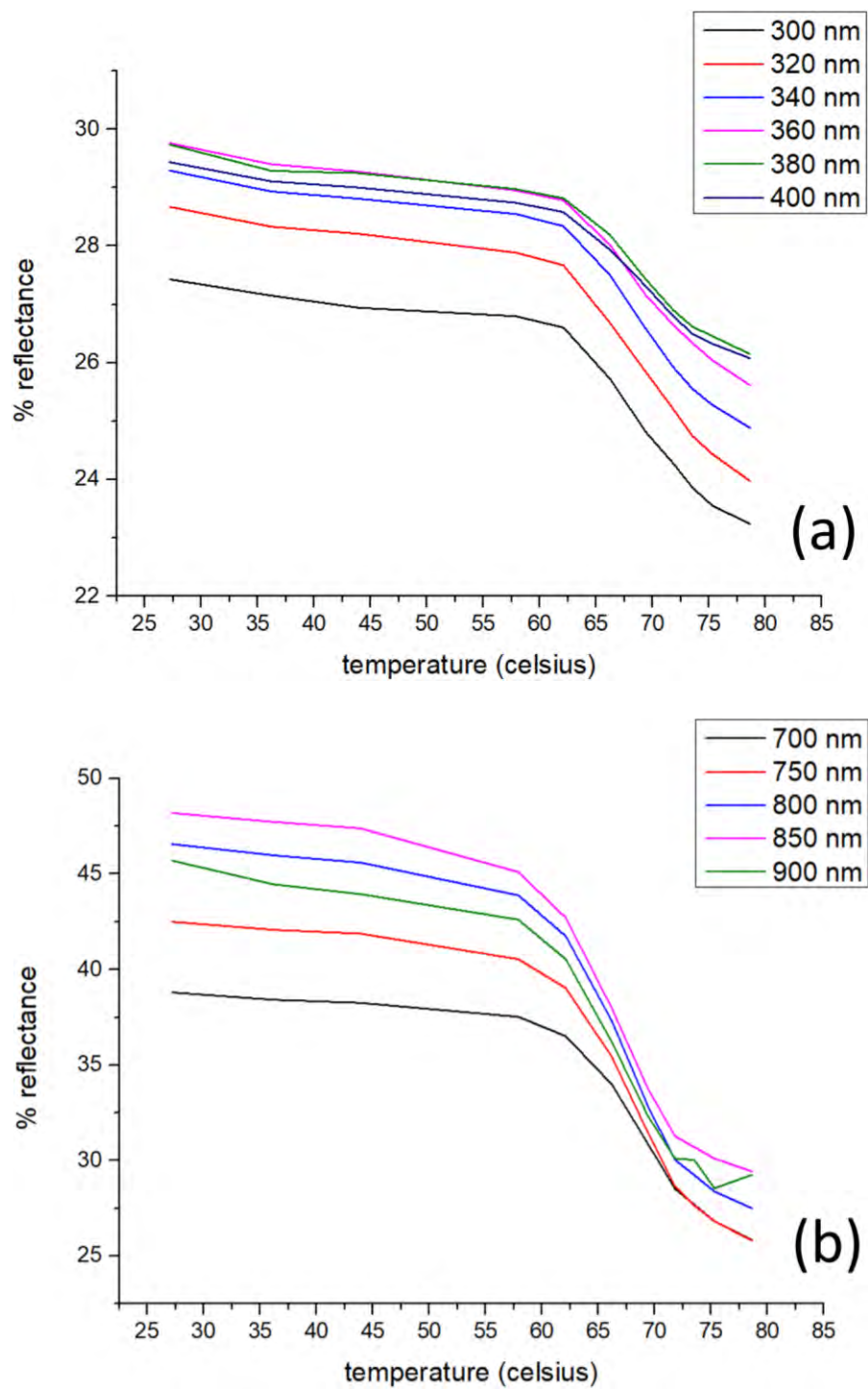

Fig. 4.3.3. The reflectance of VO₂ thin film in region of 300 - 400 nm (a) and 700 - 900 nm (b).

Since the metal-semiconductor transition results in abruptly change in optical properties as same as electrical properties then the transition temperature can also be derived from the equation used in temperature-dependent resistivity. However, the different in optical properties is not as large as those in electrical properties so it is not necessary to use logarithm scale in this derivation. The transition temperature (T_{MST}) is extracted from the derivative of the reflectance as a function of temperature. T_{MST} is the temperature where $\frac{dR}{dT}$ is minimum, when R is reflectance of VO₂ thin film, and T is the temperature.

The extracted transition temperature from the minimum of first-derivative of reflectance as a function of temperature for every curve between 300 - 400 nm and 700 - 900 nm is shown in **Fig. 4.3.4.**

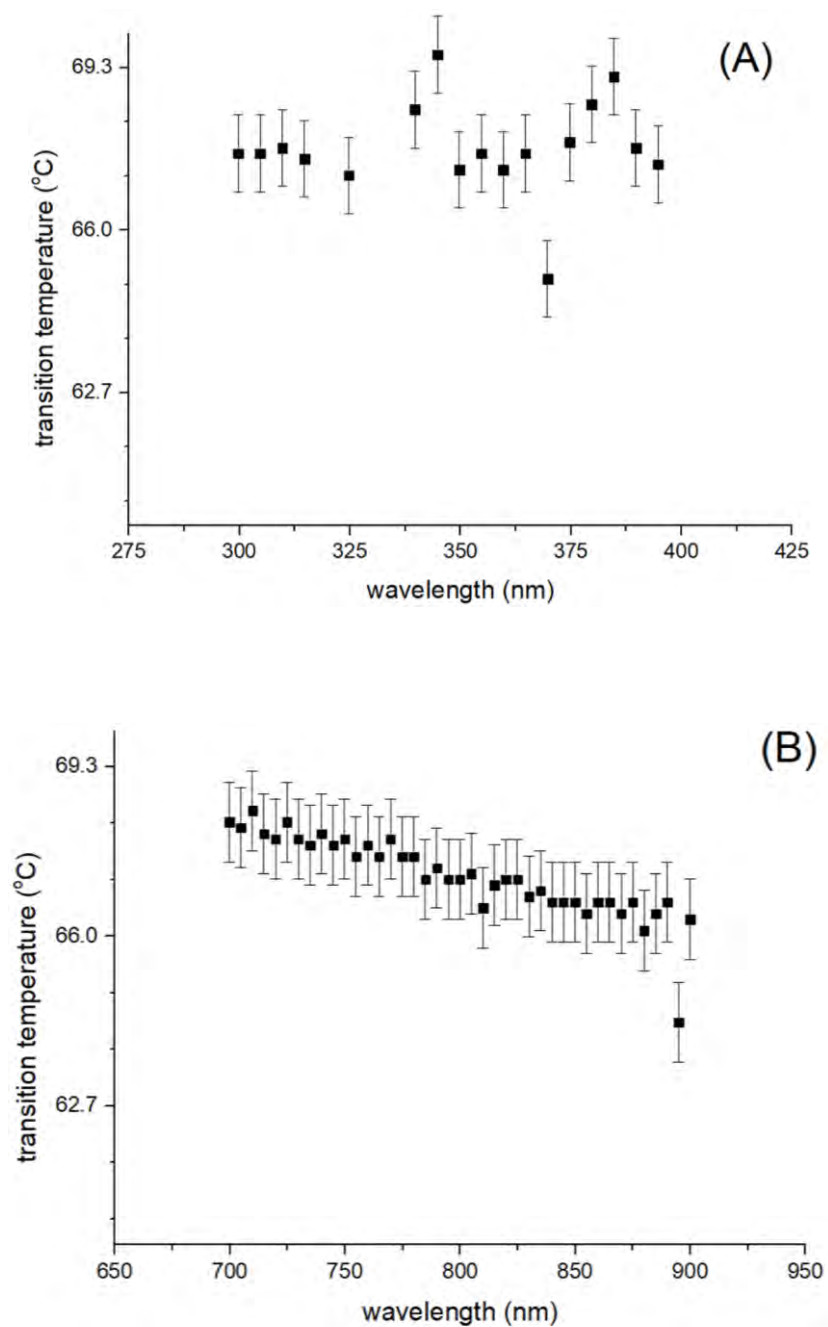

Fig. 4.3.4. The transition temperature of the sample retrieved from the minimum of first-derivative of reflectance in region of 300 - 400 nm (A) and 700 - 900 nm (B).

The result shows that the transition temperature in region of 300 - 400 nm and 700 - 900 nm is in range of 65.5 °C - 68.4 °C and 64.9 °C - 68.4 °C, respectively. The transition temperatures extracted from temperature-dependent optical reflection are less than the one retrieved from the electrical resistance measurement. This is probably due to the photoexcitation. The energy from spectroscopy spectrum can excite the electrons in the valence band to the conduction band. Thus, the photoexcitation can induce the smaller energy band gap which results in a lower phase transition-driving thermal energy and lower phase transition temperature consequently.[31]

Chapter 5. Conclusion

This senior project is a study of UV-Vis-IR spectroscopy on VO₂ thin films near the metal-semiconductor phase transition. First, the quality of the 100 nm VO₂ / c-Al₂O₃ thin film was investigated by phase transition temperature analysis. To determine the phase transition temperature of the VO₂ thin film, the resistance varied by temperature was observed by multimeter. The resistance immediately drops when the VO₂ thin film sample cross the transition temperature. The resistance measurement shows that the VO₂ thin film sample has a transition temperature at 73 ± 5 °C. To drive the VO₂ thin film to the phase transition temperature, the mini hot plate was calibrated and adapted to UV-Vis-IR spectrophotometer setting for VO₂ thin film heating. The temperature dependent spectroscopy of VO₂ thin film was measured in range of 200 - 900 nm. The measurement shows that the reflectance of VO₂ thin film oscillates by the wavelength. The rapid change in reflectance across the metal-semiconductor phase transition is obviously observed in region of 300 - 400 nm and 700 - 900 nm. By the minimum of the first-derivative of reflectance as a function of wavelength, the extracted phase transition temperature of VO₂ thin film in region of wavelength 300 - 400 nm and 700 - 900 nm are in range of 65.5 °C - 68.4 °C and 64.9 °C - 68.4 °C respectively. The transition temperatures extracted by optical method is less than those retrieved from ordinally electrical method. It is most likely due to the photoexcitation.

REFERENCES

- [1] F. Gervais and W. Kress. Lattice dynamics of oxides with rutile structure and instabilities at the metal-semiconductor phase transitions of NbO₂ and VO₂. *Physical Review*. B31, 4809. (1985)
- [2] F. J. Morin. Oxide which Show a Metal-to-Insulator Transition at the Neel Temperature. *Physical Review Letters*. 3, 34. (1959)
- [3] B. Hu, Y. Ding, W. Chen, D. Kulkarni, Y. Shen, V. Tsukruk and J.L. Wang. External-Strain Induced Insulating Phase Transition in VO₂ Nanobeam and Its Application as Flexible Strain Sensor. *Advanced Materials* 22, 45. (2010)
- [4] V. Eyert. The metal-insulator transition of VO₂. *Annalen der Physik*. 11, 650. (2002)
- [5] S. Kittiwatanakul. Study of Metal-Insulator Transition in Strongly Correlated Vanadium Dioxide Thin Films (Doctoral dissertation, University of Virginia, United states). (2014)
- [6] S. Shin, S. Suga, M. Taniguchi, M. Fujisawa, H. Kanzaki, A. Fujimori, H. Daimon, Y. Ueda and K. Kosuge. Vacuum-ultraviolet reflectance and photoemission study of the metal-insulator phase transitions in VO₂, V₆O₁₃ and V₂O₃. *Physical Review*. 15, 41. (1990)
- [7] A. Cavalleri, M. rini and R. W. Schoenlein, Ultra-Broadband Femtosecond Measurements of the Photo-Induced Phase Transition in VO₂. *Journal of Physical Society of Japan*. 75, 011004. (2006)
- [8] S. Kumar, F. Maury and N. Bahlawane, Electrical Switching in Semiconductor-Metal Self-Assembled VO₂ Disordered Metamaterial Coatings. *Scientific Report*. 6, 37699. (2016)
- [9] M. Becker, A. Buckman and R. Walser. Femtosecond laser excitation dynamics of the semiconductor-metal phase transition in VO₂. *Journal of Applied Physics*. 79, 2404-2408. (1996)

- [10] H. A. Atwater, I. M. Pryce and R. M. Briggs. Compact silicon photonic wave-guide modulator based on the vanadium dioxide metal-insulator phase transition. *Optics Express* 18, 11192. (2010)
- [11] A. Cavalleri, C. Toth, C.W. Siders, J.A. Squier, F. Raski, R. Forget and J.C. Kieffer. Femtosecond structural dynamics in VO₂ during an ultrafast solid-solid phase transition. *Physical Review Letters*. 87, 237401. (2001)
- [12] V. R. Morrison, R.P. Chatelain, K. Tiwari, A. Hendaoui, A. Bruhacs and M. Chaker. A photoinduced metal-like phase of monoclinic VO₂ revealed by ultrafast electron diffraction. *Science*. 346, 445-448. (2014)
- [13] Y.L. Tang, H.L. Yin, S. Chen, Yang Lui, W.J. Zhang, X. Jiang, L. Zhang, J. Wang, L.X. You and J.Y. Guan. Measurement-device-independent quantum key distribution over 200 km. *Physical Review Letters*. 113, 190501. (2014)
- [14] S. Wall, L. Foglia, D. Wegkamp, K. Appavoo, J. Nag, R.F. Haglund, J. Stahler and M. Wolf. Tracking the evolution of the electronic and structural properties of VO₂ during the ultrafast photoinduced insulator-metal transition. *Physical Review*. B87, 115126. (2013)
- [15] D. Wegkamp, M. Herzog, L. Xian, M. Gatti, P. Cudazzo, C.L. McGahan, R. Marvel, R. Haglund, A. Rubio, M. Wolf and J. Stahler. Instantaneous band gap collapse in photoexcited monoclinic VO₂ due to photocarrier doping. *Physical Review Letters*. 113, 21. (2014)
- [16] C.G. Granqvist. *Handbook of inorganic electrochromic materials*. Elsevier Science, Amsterdam. (1995)

- [17] A. Gunta, R. Aggarwal, P. Gupta, T. Dutta, R.J. Narayan and J. Narayan. Semiconductor to metal transition characteristics of VO₂ thin films grown epitaxially on Si. *Journal of Applied Physics*. 95, 111915. (2009)
- [18] T. Driscoll, H.T. Kim, B.G. Chae, M.D. Ventra and D.N. Basov. Phase-transition driven memristive system. *Journal of Applied Physics*. 95, 043503. (2009)
- [19] M.J. Dicken, K. Aydin, I.M. Pryce, L.A. Sweatlock, E.M. Boyd, S. Walavalkar, J. Ma and H.A. Atwater. Frequency tunable near-infrared metamaterials base on VO₂ phase transition. *Optics Express*. 17, 20. (2009)
- [20] J.S. Kyoung, M.A. Seo, S.M. Koo, H.R. Park, H.S. Kim, B.J. Kim, H.T. Kim, N.K. Park, D.S. Kim and K.J.Ahn. Active terahertz metamaterials: Nano-slot antennas on VO₂ thin films. *Physical Status Solidi*. C8,1227. (2011)
- [21] H.W. Verleur, A. S. Barker and C. N. Berglund. Optical Properties of VO₂ between 0.25 and 5 eV. *Physical Reviews*. 172, 788. (1968)
- [22] M. Currie, M. A. Mastro and V. D. Wheeler. Characterizing the tunable refractive index of vanadium dioxide. *Optical Materials Express*. 7, 5. (2017)
- [23] T.V. Son, K. Zongo, C. Ba, G. Beydaghyan and A. Hache. Pure optical phase control with vanadium dioxide thin films. *Optical Communications*. 320,151. (2014)
- [24] W. Chenghao, Z. Zhen, D. Woolf, M.C. Hessel, J. Rensburg, J. Hensley, Y. Xiao, A. Shasafi, J. Salman, S. Richter, Y. Sun, M. M. Qazibash, R. Schmidt-Grund, C. Ronning, S. Ramanathan and M. Kats. Optical properties of thin-film vanadium dioxide from the visible to the far infrared. *Annalen der Physik*. 531,10. (2019)

- [25] H. Skoog, J. Holler and S. Crouch. Principles of Instrumental Analysis (6th ed.) Cengage Learning. Ohio. (2007)
- [26] J.A. Zeitler, P. Taday, D. Newnham, M. pepper, K. C. Gordon and T. Rades. Teraheartz pulsed spectroscopy and imaging in the pharmaceutical setting. Journal of Pharmacy and Pharmacology. 59, 2. (2007)
- [27] Shimadzu UV-VIS spectrophotometers (UV-2600/2700 series) User Manual. Shimadzu Corporation. Japan. (2011)
- [28] V.A. Klimov, I.O. Timofeeva, S.D. Khanin, E.B. Shudrin, A.V. Ilinskii and F. Silva-Andrade. Hysteresis loop construction for the metal-semiconductor phase transition in vanadium dioxide films. Technical Physics. 47,1134. (2002)
- [29] Md. Sultan and N. Sultanan. Analysis of Reflectance and Transmittance Characteristics of Optical Thin Film for Various Film Materials, Thicknesses and Substrate. Journal of Electrical & Electronic Systems. 4,3. (2015)
- [30] C. Lamsal and N. M. Ravindra. Optical properties of vanadium oxides-an analysis. Materials Science. 48, 6341-6351. (2013)
- [31] A. Pashkin, C. Kubler, H. Ehrke, R. Lopez, A. Halabica, R.F. Haglund, R.Huber and A. Leitenstorfer. Ultrafast insulator-metal phase transition in VO₂ studied by multiterahertz spectroscopy. Physical Reviews. B83, 195120. (2011)