

CHAPTER V

APPLICATIONS



The previous chapter described about the properties of Ni, Cu metals. This chapter concerns with the effect of these properties to the fabrication of solar cells and alpha-radiation detector.

5.1 Fabrication of Solar Cells and Concentrated Solar Cells

In our experiment, solar cells and concentrated solar cells were distinguished by grid pattern and resistivity of wafer.

Solar cells were fabricated by using p-type Si wafer with resistivity of 4-5 Ω -cm, 320 μm thick, orientation $\langle 111 \rangle$, lapped wafer. The No 2 mask was used.

Concentrated solar cells were fabricated by using p-type Si wafer with resistivity of 1-2 Ω -cm, 285 μm thick, orientation $\langle 111 \rangle$, polished wafer. The No 3. mask was used.

The purpose of this experiment was to compare electroless and electroplating process at the same condition. The electroless process was described in Appendix C.

Solar cells and concentrated solar cells were fabricated as in Appendix B.1

Typical schematic representation of solar cells and concentrated solar cells were shown in Fig. 12 and Fig. 13 respectively.

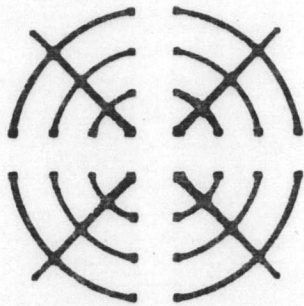

Positive mask

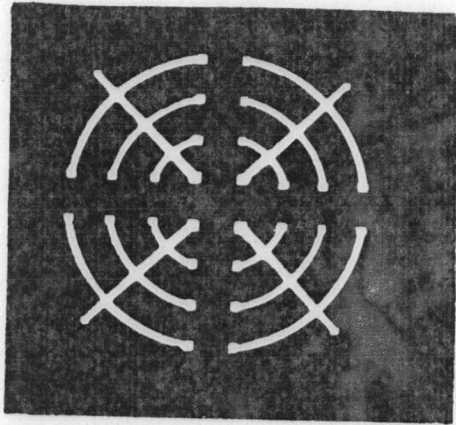

Negative mask

Mask pattern No 2 for solar cells

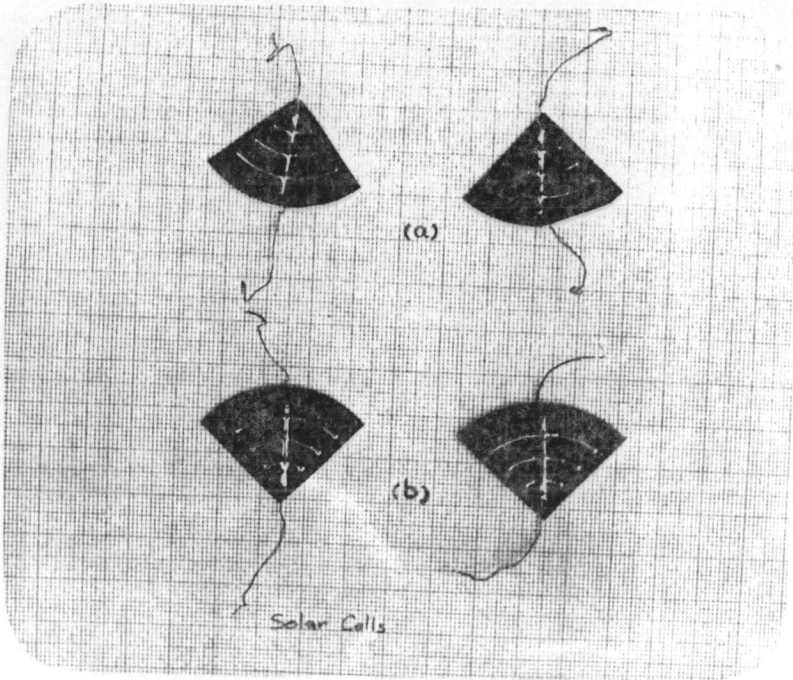
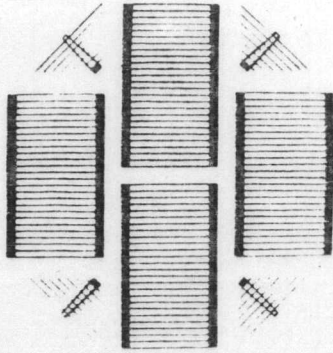
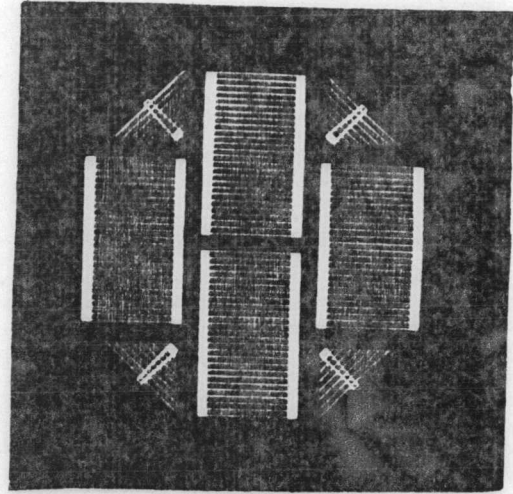

Fig. 12 Schematic representation of solar cells

(a) Electroplated contact (b) Electroless plated contact



Positive mask



Negative mask

Mask pattern No 3 for concentrated solar cells

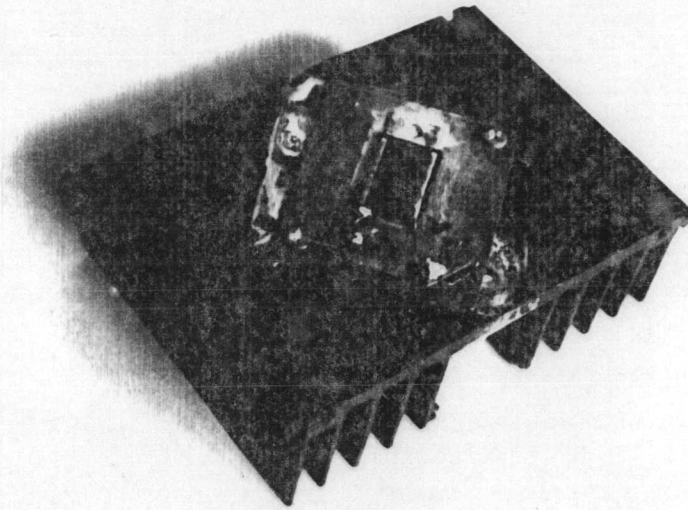

Concentrated Solar cell

Fig. 13 Schematic representation of concentrated solar cells

5.2 Fabrication of Alpha-Radiation Detector

The purpose of this section was to improve the alpha-radiation detector fabricated by SDRL ⁽⁹⁾. The recent detector was made of p-type polished monocrystalline silicon with resistivity 7500 Ω -cm. Its diameter was 2.4 cm. Two zone diffusion technique with phosphoric acid as an impurity source was used to form a diffusion layer at 900°C (Fig. 14). The quality of the detector contacts was improved by nickel electroplating. This device was encapsulated in a brass case which was ready for application.

Alpha-radiation detectors were fabricated as in the Appendix B.2.

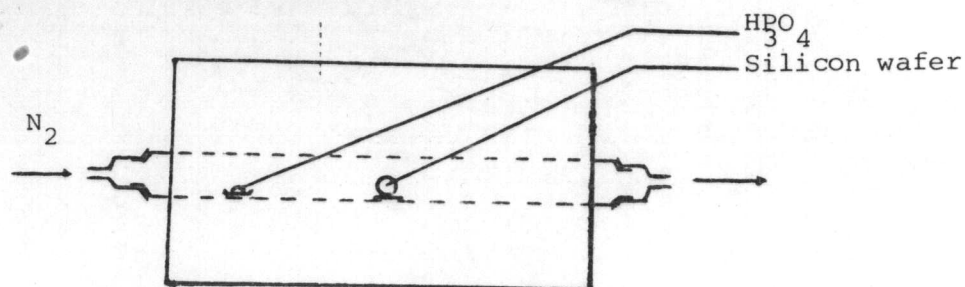
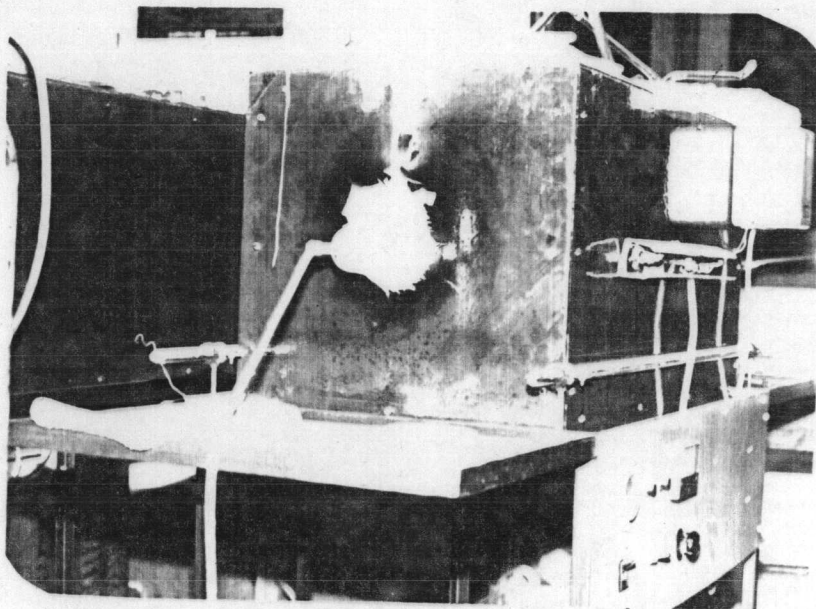

Fig. 14 Two zone diffusion

Typical schematic representation of alpha-radiation detector in
 Fig. 15 and Fig. 16 .



Fig. 15 Mask pattern the front contact of
 alpha-radiation detector

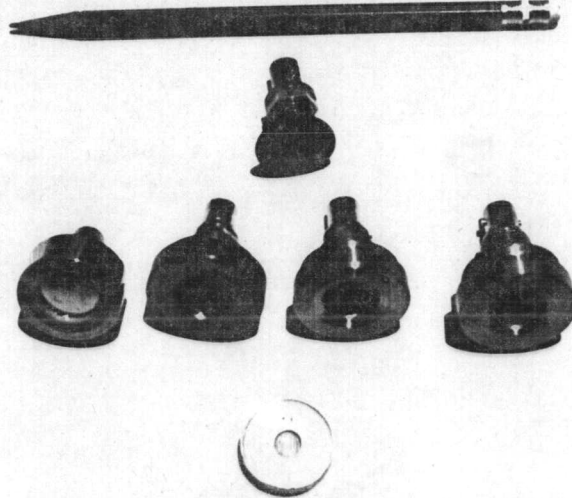

Fig. 16 Encapsulated alpha-radiation detector

Typical schematic representations of testing alpha-radiation detector were shown in Fig. 7 and Fig. 8 .

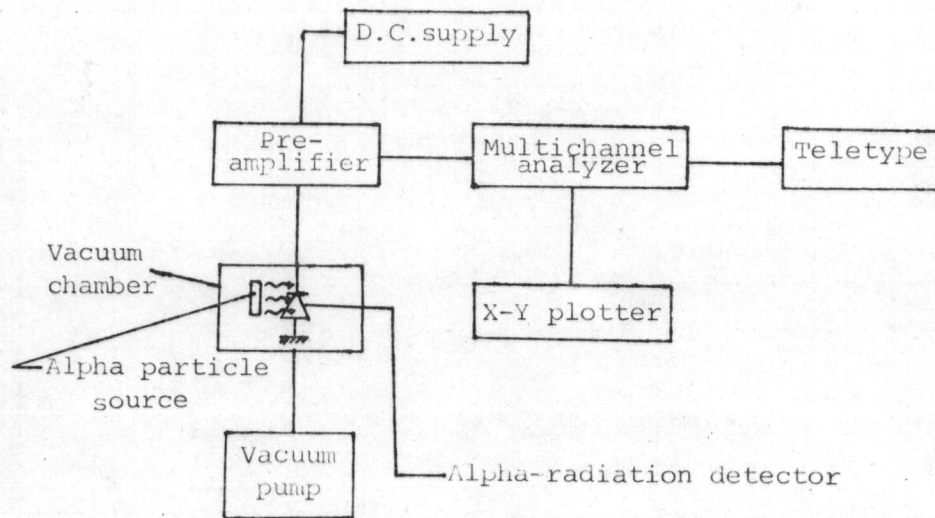

Fig. 17 Schematic diagram of testing alpha-radiation detector

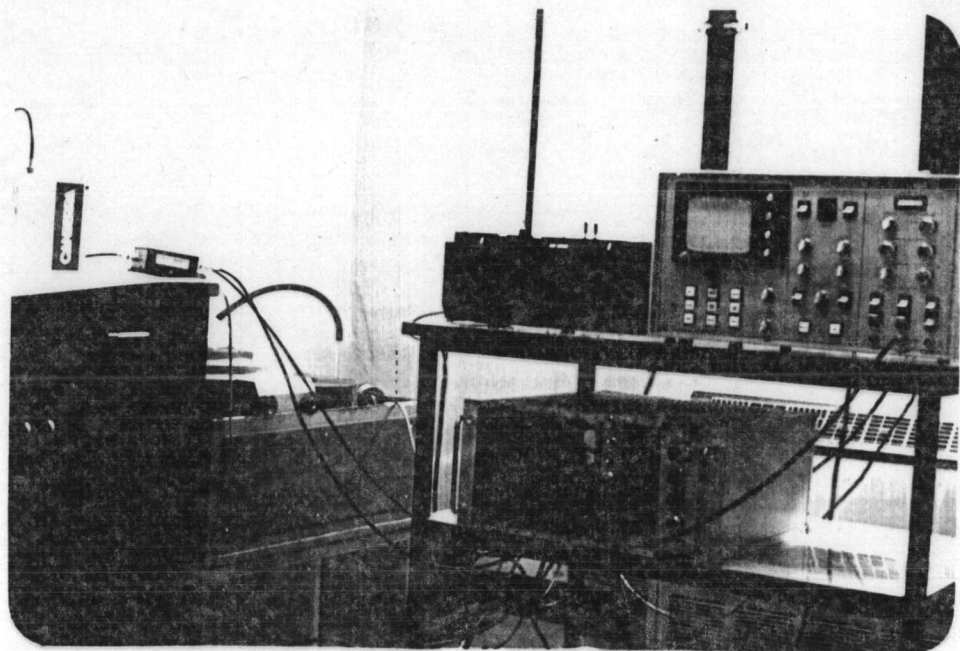

Fig. 18 The equipment of testing alpha-radiation detector