

OCCURRENCE OF 17 ALPHA-METHYLTESTOSTERONE
IN MASCULINIZATION POND OF NILE TILAPIA FRY

Miss Kanyaratt Waiyaput

A Thesis Submitted in Partial Fulfillment of the Requirements
for the Degree of Master of Science Program
Environmental Management
(Interdisciplinary Program)
Graduate School
Chulalongkorn University
Academic Year 2011

Copyright of Chulalongkorn University

บทคัดย่อและแฟ้มข้อมูลฉบับเต็มของวิทยานิพนธ์ตั้งแต่ปีการศึกษา 2554 ที่ให้บริการในคลังปัญญาจุฬาฯ (CUIR)

เป็นแฟ้มข้อมูลของนิสิตเจ้าของวิทยานิพนธ์ที่ส่งผ่านทางบัณฑิตวิทยาลัย

The abstract and full text of theses from the academic year 2011 in Chulalongkorn University Intellectual Repository (CUIR)
are the thesis authors' files submitted through the Graduate School.

การปรากฏสารเซเวนทีนแอลฟาเมทิลเทสโทสเตอโรนในบ่อแปลงเพศปลานิล

นางสาวกัญญารัตน์ ไวยพุด

วิทยานิพนธ์นี้เป็นส่วนหนึ่งของการศึกษาตามหลักสูตรปริญญาวิทยาศาสตรมหาบัณฑิต
สาขาวิชาการจัดการสิ่งแวดล้อม (สหสาขาวิชา)
บัณฑิตวิทยาลัย จุฬาลงกรณ์มหาวิทยาลัย
ปีการศึกษา 2554
ลิขสิทธิ์ของจุฬาลงกรณ์มหาวิทยาลัย

Thesis Title OCCURRENCE OF 17 ALPHA -
METHYLTESTOSTERONE IN MASCULINIZATION
POND OF NILE TILAPIA FRY
By Miss Kanyaratt Waiyaput
Field of Study Environmental Management
Thesis Advisor Assistant Professor Tawan Limpiyakorn, Ph.D.
Thesis Co-advisors Assistant Professor Natchanun Leepipatpiboon, Dr.rer.nat.
Professor Say Kee Ong, Ph.D.

Accepted by the Graduate School, Chulalongkorn University in Partial Fulfillment of
the Requirements for the Master's Degree

.....Dean of the Graduate School
(Associate Professor Pornpote Piumsomboon, Ph.D.)

THESIS COMMITTEE

..... Chairman
(Assistant Professor Ekawan Luepromchai, Ph.D.)

..... Thesis advisor
(Assistant Professor Tawan Limpiyakorn, Ph.D.)

..... Thesis Co-advisor
(Assistant Professor Natchanun Leepipatpiboon, Dr.rer.nat.)

..... Thesis Co-advisor
(Professor Say Kee Ong, Ph.D.)

..... Examiner
(Pichet Chaiwiwatworakul, Ph.D.)

..... External Examiner
(Sorawit Powtongsook, Ph.D.)

กัญญารัตน์ ไวยพุด: การปรากฏของสารเซเวนทีนแอลฟาเมทิลเทสโทสเตอโรนในบ่อแปลงเพศปลาไนล (OCCURRENCE OF 17 ALPHA-METHYLTESTOSTERONE IN MASCULINIZATION POND OF NILE TILAPIA FRY) อ. ที่ปริกษาวิทยานิพนธ์หลัก : ผศ.ดร.ตะวัน ลิมปิยากร, อ. ที่ปริกษาวิทยานิพนธ์ร่วม : ผศ.ดร.ณัฐชนัญ ลิพิพัฒน์ไพบูลย์ , Prof. Say Kee Ong 82 หน้า.

17แอลฟาเมทิลเทสโทสเตอโรน (MT) เป็นฮอร์โมนเพศชายที่ใช้ในกระบวนการแปลงเพศปลาไนล ซึ่งอาจตกค้างและปล่อยลงสู่แหล่งน้ำหรือดิน ทำให้เกิดผลกระทบต่อระบบนิเวศน์โดยรอบบริเวณ วัตถุประสงค์ของงานวิจัยนี้คือการศึกษาการปรากฏของ MT ในบ่อแปลงเพศปลาไนลและบริเวณจุดปล่อยน้ำทั้ง วิธีการสกัด MT จากตัวอย่างน้ำและดินทำโดยใช้ตัวดูดซับของแข็งและตัวดูดซับของเหลวตามลำดับ วิธีการวัดความเข้มข้นของ MT ในตัวอย่างสกัดใช้เครื่อง UPLC-MS/MS ร้อยละการคืนกลับเฉลี่ยของวิธีการสกัดตัวอย่างน้ำ (โดยการเติม MT มาตรฐาน 10 และ 100 นาโนกรัมต่อลิตร) และตัวอย่างดิน (โดยการเติม MT มาตรฐาน 1 และ 10 ไมโครกรัมต่อกิโลกรัม) อยู่ในช่วง 80 - 84 % และ 60 - 71 % ตามลำดับ จากการตรวจวัด MT ภายในหนึ่งวัน พบว่า MT ในเกือบทุกส่วน (น้ำ ตะกอนลอยและตะกอนจม) มีความเข้มข้นสูงสุดในเวลา 16.00 ซึ่งเป็นการให้อาหารครั้งสุดท้ายของวัน MT ถูกปล่อยออกสู่สิ่งแวดล้อมได้สองทางคือ 1) จากน้ำที่ล้นที่ออกจากบ่อในแต่ละวัน (น้ำและตะกอนลอย) และ 2) จาก MT ที่ตกค้างในบ่อแปลงเพศในวันที่ 30 (น้ำ ตะกอนลอยและตะกอนจม) ความเข้มข้น MT ทั้งหมดในน้ำล้นจากบ่อและบ่อในวันที่ 30 อยู่ในช่วง 0.3 – 39.5 นาโนกรัมต่อลิตรและ 0.595 นาโนกรัมต่อลิตรตามลำดับ แม้ว่าความเข้มข้น MT ในน้ำล้นมีค่าเกินช่วงความเข้มข้นที่ส่งผลกระทบต่อสิ่งมีชีวิต (6.5 นาโนกรัมต่อลิตร) ความเข้มข้น MT ในแหล่งน้ำบริเวณจุดปล่อยมีแนวโน้มลดลงเนื่องจากผลของการเจือจางเมื่อน้ำล้นปล่อยสู่แหล่งน้ำ เมื่อเปรียบเทียบกับปริมาณ MT ในอาหารที่ใส่ลงในระบบทั้งหมด (148.85 มิลลิกรัม) ปริมาณ MT จากน้ำล้น ในช่วง 30 วัน คิดเป็นร้อยละ 0.33 (492.85 ไมโครกรัม) ปริมาณ MT ที่ตกค้างในบ่อแปลงเพศวันที่ 30 คิดเป็นร้อยละ 0.0009 (1.33 ไมโครกรัม) รวมแล้วคิดเป็นร้อยละ 0.333 (494.14 ไมโครกรัม) และเมื่อเปรียบปริมาณ MT ที่ปล่อยลงสู่สิ่งแวดล้อมทั้งหมด ปริมาณ MT ในน้ำล้นคิดเป็นร้อยละ 99.73 โดยอยู่ในสถานะน้ำร้อยละ 96.89 และสถานะตะกอนลอยร้อยละ 2.84 และปริมาณ MT ที่เหลืออยู่ในบ่อในวันที่ 30 คิดเป็นร้อยละ 0.27 เมื่อเปรียบเทียบกับ MT ปล่อยลงสู่สิ่งแวดล้อม MT อยู่ในสถานะน้ำ ตะกอนลอย และตะกอนจมคิดเป็นร้อยละ 97.06 2.93 และน้อยกว่า 0.005 ตามลำดับ เพื่อลดความเสี่ยงจาก MT ควรทำการควบคุมน้ำที่ล้นเป็นสำคัญ สำหรับ MT ในบริเวณจุดปล่อยน้ำพบ ความเข้มข้นสูงสุดที่ทางเข้าของรางระบายน้ำคอนกรีต (0.29 นาโนกรัมต่อลิตรในน้ำ และ 0.1 ไมโครกรัมต่อกิโลกรัมในตะกอนจม) โดยความเข้มข้นในน้ำและตะกอนจมลดลงถึงระดับ 0.21-0.22 นาโนกรัมต่อลิตร และ 0.06-0.07 ไมโครกรัมต่อกิโลกรัมตามลำดับ บริเวณทางออกของรางระบายน้ำคอนกรีต และในแหล่งน้ำบริเวณจุดปล่อย ความเข้มข้นของ MT ในน้ำอยู่ในช่วง 0.13- 0.14 นาโนกรัมต่อลิตรและในดิน เท่ากับ 0.01 ไมโครกรัมต่อกิโลกรัม ซึ่งมีค่าน้อยกว่าช่วงที่ส่งผลกระทบต่อสิ่งมีชีวิต งานวิจัยในอนาคตควรทำการศึกษาความเป็นไปของ MT ในบ่อแปลงเพศปลาไนล และพัฒนาวิธีตรวจวัดค่า Androgenic activity ในสภาวะที่มี MT ความเข้มข้นต่ำ

สาขาวิชา...การจัดการสิ่งแวดล้อม..... ลายมือชื่อนิสิต.....
 ปีการศึกษา2554..... ลายมือชื่อ อ.ที่ปริกษาวิทยานิพนธ์หลัก.....
 ลายมือชื่อ อ.ที่ปริกษาวิทยานิพนธ์ร่วม.....
 ลายมือชื่อ อ.ที่ปริกษาวิทยานิพนธ์ร่วม.....

5287504020 : MAJOR ENVIRONMENTAL MANAGEMENT
 KEYWORDS : NILE TILAPIA, 17ALPHA-METHYLTESTOSTERONE,
 ANDROGEN, MASCULINIZATION PROCESS

KANYARATT WAIYAPUT: OCCURRENCE OF 17 ALPHA -
 METHYLTESTOSTERONE IN MASCULINIZATION POND OF NILE
 TILAPIA FRY. ADVISOR: ASSIST. PROF. TAWAN LIMPIYAKORN,
 Ph.D., CO-ADVISOR: ASSIST. PROF. NATCHANUN
 LEEPIPATPIBOON, Dr. rer.nat., PROF. SAY KEE ONG, Ph.D., 82 pp.

17 α -methyltestosterone (MT) is a male hormone used commonly to produce an all male population in Nile tilapia farming. MT may remain in the masculinization process and be released into the surrounding water and soil bodies causing adverse impact to ecosystems. This study aims to investigate the occurrence of MT in masculinization pond of Nile tilapia fry and its discharged area. MT was extracted from water and sediment samples using SPE and LPE by methanol, respectively. MT concentration was determined using UPLC-MS/MS. The average percent recoveries of the extraction method when MT was spiked into water samples (10 and 100 ng/L) were 80 - 84 %. For the sediment samples, the average percent recoveries (1 and 10 μ g/kg) were 60 - 71 %. The monitoring during 1-day period was performed to define the time of the day that MT reached the maximum concentration. The maximum MT concentrations in most compartments (water, suspended solid, and settled solid phases) occurred at the end of the last feeding time (16.00). MT was input into the pond through the feed and was released into the environments by two approaches: 1) with the daily overflow water (water phase and suspended solids phase) and 2) with the water (water phase and suspended solid phase) and settled solid that remained in the pond on the last day of operation (day 30). In the overflow water, the overall concentrations of MT (water phase and suspended solid phase) were 0.3 - 39.5 ng/L. For MT remaining in the pond on day 30, the overall MT concentration was calculated by assuming that MT in all compartments (water, suspended solid, and settled solid phases) distributed homogeneously in the pond as at the end MT in all compartments were released with the pond water. The level of MT was found to be 0.595 ng/L. Although the ranges of the MT concentrations found in the overflow water were in the ranges reported to affect organisms (6.5 ng/L), these levels of MT can be reduced due to effect of dilution when the overflow water was released into natural receiving water. Comparing to the total mass of MT supplied into the pond with the feed (148.85 mg), 0.33 % (492.85 μ g) of MT was released with the overflow water along 30 days of operation. MT remaining in the pond on day 30 can be accounted as 0.0009 % (1.33 μ g) of the total MT supplied to the pond. In overall, 0.333% (494.18 μ g) of MT supplied to the pond was released into the environment. In the overflow water, the total mass of MT was 492.85 μ g which can be accounted for 99.73 % of overall of MT released into the environment. Comparing to the overall MT released, MT in the water phase was 96.89 % and was 2.84 % in the suspended solid phase. MT remaining in the pond was 0.27 % of the overall MT released. Combining all MT released, MT distributed 97.06 %, 2.93 %, and <0.005 % in water phase, suspended solid phase, and settled solid phases, respectively. The priority should be given to the overflow water to reduce the risk of MT released into the environment. To investigate the occurrence of MT in the discharged area, the highest concentrations of MT were found at the inlet of the concrete ditch (0.29 ng/L for water and 0.1 μ g/kg for settled solids) and the concentrations reduced to 0.21-0.22 ng/L and 0.06-0.07 μ g/kg for water phase plus suspended solid phase and settled solid, respectively, at the outlet point of the concrete ditch. The MT concentrations in the receiving water were in the range of 0.13-0.14 ng/L and it was 0.01 μ g/kg in the receiving sediment. The levels of MT in the receiving water were found to be lower than the levels reported to affect organisms (6.5 ng/L). The further study should be done to clarify fate of MT and to develop the method to detect androgenic activity under low levels in the masculinization process of Nile tilapia fry.

Field of Study : Environmental Management.....

Student's Signature

Academic Year : 2011.....

Advisor's Signature

Co-advisor's Signature

Co-advisor's Signature

ACKNOWLEDGEMENTS

First, I am deeply grateful to Assistant Professor Dr. Tawan Limpiyakorn, my thesis advisor, for his patience, sincere encouragement, and wise guidance of my thesis. I wish to thank Assistant Professor Natchanun Leepipatpiboon, my co- advisor, for her kindness supports and suggestions. I also owe a great deal to Professor Dr. Say Kee Ong, my co-advisor, whose supervision and advice have contributed substantially to my study.

Besides I gratefully acknowledge to my thesis chairman and committees, Assistant Professor Dr. Ekawan Luepromchai, Dr. Pichet Chaiwiwatworakul and Dr. Sorawit Powtongsook for their comments and suggestions.

I would like to express my profound gratitude to Center of Excellence for Environmental and Hazardous Wastes Management (EHWM), Chulalongkorn University, for granting me support to pursue my graduate studies. The support has given me to work on a thesis am interest.

I also would like to thank Ms. Suthira Puangsiri, her family all famers and local people who were participating with my field works, for their assistance in field collection.

Many thanks also go to my colleagues and staff at EHWM and Department of Chemistry, Faculty of Science, Chulalongkorn University, for their assistance, and the best relationship, friends and seniors at Faculty of Engineering, Chulalongkorn University, especially Ms. Papitchaya Srithep, who always support me during study in Master degree.

Finally, for their love, my deepest thanks go to my family who are my inspiration for living and doing everything.

CONTENTS

	Page
ABSTRACT IN THAI	iv
ABSTRACT IN ENGLISH	v
ACKNOWLEDGEMENTS	vi
CONTENTS	vii
LIST OF FIGURES	ix
LIST OF TABLES	xi
ABBREVIATIONS	xiii
CHAPTER I INTRODUCTION	
1.1 Theoretical Background.....	1
1.2 Objective.....	2
1.3 Hypotheses.....	2
1.4 Scope of the Study	3
CHAPTER II LITERATURE REVIEW	
2.1 Masculinization of Nile tilapia.....	4
2.2 Endocrine disrupting chemicals.....	4
2.3 17 α - methyltestosterone (MT).....	5
2.4 Occurrence of MT in environment.....	7
2.5 Degradation of MT	7
2.6 Sorption.....	8
2.7 Effect of MT aquatic and terrestrial organism.....	8
2.8 Determination of MT.....	9

CHAPTER III METHODOLOGY

3.1 Experimental Framework.....	11
3.2 Materials.....	12
3.3 Description of site and Nile tilapia fry masculinization process.....	12
3.4 Experiment I: Preliminary study.....	15
3.5 Experiment II: Occurrence of MT in masculinization process of Nile tilapia fry..	17
3.6 Experiment III: Occurrence of MT in discharged area of concrete ponds.....	21

CHAPTER IV RESULTS AND DISSCUSION

4.1 Preliminary study.....	23
4.2 Occurrence of MT in Masculinization process of Nile tilapia fry.....	31
4.3 Occurrence of MT in discharged area of concrete ponds.....	44
4.4 Summary of occurrence of MT in masculinization ponds of Nile tilapia fry and discharged area.....	47

CHAPTER V CONCLUSIONS AND RECOMMEDATIONS

5.1 Conclusions.....	50
5.2 Recommendations for further study.....	52

REFERENCES	53
-------------------------	----

APPENDICES	57
-------------------------	----

APPENDIX A: CALCULATION OF MT CONCENTRATION.....	58
--	----

APPENDIX B.....	78
-----------------	----

BIOGRAPHY	82
------------------------	----

LIST OF FIGURES

	Page
Figure 2.1 Structure of 2.1a 17 α -methyltestosterone (MT) 2.1b Testosterone.....	6
Figure 3.1 Experimental framework.....	11
Figure 3.2 Schematic of 3.2a concrete masculinization pond 3.2b plastic masculinization pond.....	12
Figure 3.3 Layout of Nile tilapia farm.....	13
Figure 3.4 Schematic diagram of Nile tilapia masculinization area.....	14
Figure 3.5 Schematic diagram of masculinization pond of Nile tilapia fry.....	17
Figure 3.6 Collecting points for sample collection in masculinization pond.....	18
Figure 3.7 Schematic diagram of discharged area.....	22
Figure 4.1 Chromatogram of standard 10 ppb of 17 α -methyltestosterone.....	25
Figure 4.2 Mass spectrometry data of standard 10 ppb of 17 α -methyltestosterone.....	25
Figure 4.3 Chromatogram of standard 100 ppb of 17 α -methyltestosterone.....	25
Figure 4.4 Mass spectrometry data of standard 100 ppb of 17 α -methyltestosterone.....	26
Figure 4.5 Chromatogram of blank water sample.....	26
Figure 4.6 Mass spectrometry data of blank water sample.....	26
Figure 4.7 Chromatogram of DI water sample spiked 10 ng/L of 17 α -methyltestosterone...	27
Figure 4.8 Mass spectrometry data of DI water sample 10 ng/L of 17 α -methyltestosterone..	27
Figure 4.9 Chromatogram of blank sediment sample.....	30
Figure 4.10 Mass spectrometry data of blank sediment sample.....	30
Figure 4.11 Mass spectrometry data of uncontaminated MT sediment sample spiked 1 μ g/L of 17 α -methyltestosterone.....	30
Figure 4.12 Chromatogram of uncontaminated MT sediment sample spiked 1 μ g/L of 17 α - methyltestosterone	31
Figure 4.13 Concentration of MT in water compartment of plastic masculinization pond during feeding period from 9.00 to 16.00.....	32
Figure 4.14 Concentrations of MT in suspended solid compartment of plastic masculinization pond during feeding period from 9.00 to 16.00.....	33
Figure 4.15 Concentrations of MT in water compartment of concrete masculinization pond during feeding period from 9.00 to 16.00.....	34

Figure 4.16 Concentrations of MT in settled solid compartment of concrete masculinization pond during feeding period from 9.00 to 16.00.....	34
Figure 4.17 Percents of MT in water phase and suspended solid phase in concrete masculinization pond.....	41
Figure 4.18 Percents and mass (microgram) of MT in each compartment in the pond on day 30.....	42
Figure 4.19 Profiles of MT concentrations in water (water phase + sus-s phase).....	46
Figure 4.20 Profiles of MT concentrations in settled solids.....	47
Figure 4.21 Concentrations of MT in each compartment of masculinization pond (2240 L) of Nile tilapia during 30 day of the operation.....	47
Figure 4.22 Percent of MT in each compartment compared to the total input mass of MT.....	48
Figure 4.23 Mass and percent of MT in each compartment compared to total mass of MT released to environment.....	48
Figure 4.24 Concentration of MT concentrations of MT in each compartment in discharged area during 30 day.....	49
Figure A-1 Calibration curve of MT.....	74
Figure A-2 Chromatogram of standard 10 ppb of MT.....	74
Figure A-3 Mass spectrometry data for standard 10 ppb of MT.....	74
Figure A-4 Chromatogram of standard 50 ppb of MT.....	75
Figure A-5 Mass spectrometry data of standard 50 ppb of MT.....	75
Figure A-6 Chromatogram of standard 100 ppb of MT.....	76
Figure A-7 Mass spectrometry data of standard 100 ppb of MT.....	76
Figure A-8 Chromatogram of spiked water sample set a.....	77
Figure A-9 Mass spectrometry data of spiked water sample set a.....	77

LIST OF TABLES

	Page
Table 2.1 Physicochemical properties of 17methyltestosterone.....	6
Table 2.2 Active dosage levels and effects of MT to the various organisms.....	9
Table 3.1 Sampling schedule during 1- day monitoring.....	19
Table 3.2 Sampling schedule for observation of MT in overflow water during 30 days.....	20
Table 3.3 Schedule for observation of MT remaining in the ponds at the end of operation (day 30).....	21
Table 3.4 Sampling schedule for occurrence of MT in discharged area.....	22
Table 4.1 Concentration and percent recovery of MT in spiked water sample.....	23
Table 4.2 Concentration and percent recovery of MT in spiked sediment sample.....	29
Table 4.3 Concentrations of MT in water and suspended solid phase of plastic masculinization pond during 1 day.....	32
Table 4.4 Concentrations of MT in water, suspended solid, and settled solid phase of concrete masculinization pond during 1 day.....	33
Table 4.5 The amount of feed and MT in each day in concrete masculinization pond during 21 days of operation	37
Table 4.6 The amount of feed and MT in each day in concrete masculinization pond during day 22 to day 30 of operation.....	38
Table 4.7 Concentrations of MT in each compartment of concrete masculinization pond during 30 days.....	39
Table 4.8 Daily mass of MT and equivalent concentration of MT in the overflow water during 30 day.....	39
Table 4.8 Daily mass of MT and equivalent concentration of MT in the overflow water during 30 day (<i>continued</i>).....	40
Table 4.9 Mass, percent and equivalent concentrations of MT in the pond on day 30..	42
Table 4.10 Mass and percent of MT released into the environment.....	43
Table 4.11 Mass and percent of MT released into the environment compared to the feed input.....	43
Table 4.12 Concentrations of MT in water and settled solid samples at three different	

locations on day 1, 16, and 30.....	45
Table A-1 Concentration and percent recovery of MT in spiked water sample.....	61
Table A-2 Concentration and percent recovery of MT in spiked sediment sample.....	62
Table A-3 Concentration of MT in water phase of plastic masculinization pond during 1 day.....	63
Table A-4 Concentration of MT in suspended solids phase of plastic masculinization pond.....	64
Table A-5 Concentration of MT in water phase of concrete masculinization pond during 1 day.....	65
Table A-6 Concentration of MT in suspended solids phase of concrete masculinization pond during 1 day.....	65
Table A-7 Concentration of MT in settled solids phase of concrete masculinization pond during 1 day.....	66
Table A-8 Concentration of MT in water phase of concrete masculinization pond during 30 days.....	67
Table A-9 Concentration of MT in suspended solids phase of concrete masculinization pond during 30 day.....	68
Table A-10 Concentration of MT in settled solids phase of concrete masculinization pond during 30 days.....	69
Table A-11 Concentration of MT in waster phase of discharged area during 30 days..	70
Table A-12 Concentration of MT in suspended solids phase of discharged area during 30 days.....	71
Table A-13 Concentration of MT in settled solids phase of discharged area during 30 days.....	72
Table A-14 Percent recoveries in each set of water sample.....	73
Table A-15 Percent recoveries in each set of suspended solid samples.....	73
Table A-16 Percent recoveries in each set of settled solid samples.....	73
Table B-1 Mass of suspended solids during 30 day of masculinization process.....	79
Table B-2 The calculation of mass of MT in the overflow water during 30 day.....	80
Table B-3 Percent MT released in water phase and suspended solid phase released in each day from the overflow water.....	81

ABBREVIATIONS

μg	Microgram
$\mu\text{g}/\text{kg}$	Micrograms per kilogram
$\mu\text{g}/\text{L}$	Micrograms per liter
ACN	Acetonitrile
C_{eff}	Concentration of effluent water
C_{feed}	Concentration of MT in feed
C_{in}	Concentration of MT in influent water
$C_{\text{set-s}}$	Concentration in settled solids phase
$C_{\text{sus-s}}$	Concentration of MT in suspended solids phase
C_{w}	Concentration of MT in water phase
g/mole	Grams per mole
GC-MS(/MS)	Gas chromatography-mass or tandem mass spectrometry
HPLC	High-performance liquid chromatography
K_{ow}	Octanol- water partitioning coefficient
L/d	Liters per day
L/h	Liters per hour
L/min	Liters per minute
LC-MS(/MS)	Liquid chromatography-mass or tandem mass spectrometry
LOD	Limit of detections
LOQ	Limit of quantifications
LPE	Liquid phase extraction
M_{feed}	Mass of feed daily supplied
mg	Milligram
mg/L	Milligrams per liter
$M_{\text{set-s}}$	Mass of settled solids
$M_{\text{sus-s}}$	Mass of suspended solids
MT	17 α - methyltestosterone
ng/L	Nanograms per liter
Q_{in}	Flow rate of influent water

ABBREVIATIONS

Q_{out}	Flow rate of effluent water
Set-s	Settled solids
SPE	Solid phase extraction
STP	Sewage treatment plant
Sus-s	Suspended solids
UPLC-MS/MS	Ultra performance liquid chromatography- tandem mass spectrometry
US EPA	United State Environment Protection Agency
V_{pond}	Volume of pond

CHAPTER I

INTRODUCTION

1.1 Theoretical Background

Nile tilapia is one of the most popular aquacultural products of Thailand. The predominant characteristics of Nile tilapia are easy to cultivate with various kinds of food, tolerant to diseases and adaptable under environmental stress, for instance, low dissolved oxygen concentration, high salinity, high ammonia concentration and high water temperature (Macintosh and Little, 1995; Green *et al.*, 1997; Boca *et al.*, 1999).

The production of Nile tilapia can be accelerated by promoting sex reversal to an all-male population (Penpan, 2004; Francesc, 2001). Male tilapia are more preferable to female owing to the double growth rate and larger body size (Macintosh and Little, 1995). There are several procedures to produce an all-male Nile tilapia population, which include manual sexing, interspecific hybridization, use of genetically supermale tilapia (YY male technology), and hormonal sex reversal (Beardmore, 2001).

Male-inducing hormones is commonly applied to reverse sex of Nile tilapia fry after their fertilization. 17α -methyltestosterone (MT) is the most popular male hormone for an all male population production. After hormone treatment period more than 90% of the fry's population can be induced to male (Kriangsak *et al.*, 2006).

MT in uneaten feed and unmetabolized MT excreted from fish may remain in the masculinization ponds and was discharged to receiving streams so MT can contaminate to surrounding water and soil environments causing adverse effect to aquatic and terrestrial organisms (Contreras-Sánchez, 2001).

MT has been reported that caused effect to human and ecological organisms, for instance inducing the production of nonmalignant tumors in the liver (Soe *et al.*, 1992), decreasing the circulation yolk-precursor protein vitellogenin in female eelpout (*Zoarces viviparous*) at 10 -50 ng/L of MT (Kongsgaard, 2006), the fish-to-fish transfer of steroids (Budworth & Senger, 1993), biased sex ratios in untargeted organisms (Abucay *et al.*, 1997), and paradoxical feminization (Piferrer & Donaldson, 1991; Piferrer *et al.*, 1993; Rinchard *et al.*, 1999; Eding *et al.*, 1999). Gomelsky *et al.* (1994) also reported that the masculinization of common carps

(*Cyprinus carpio*) were significantly appeared when the fish exposed to MT contaminated water.

Some researchers implied that MT or its metabolites remained in water body at the concentrations high enough to reverse sex of non-target organisms. A few studies indicated that the sex ratios were significantly biased when non-targeted fish were raised in the same pond with MT-targeted fish (Abucay and Mair, 1997; Abucay *et al.*, 1997).

Analytical methods for detection and quantification of remaining MT in various phases of environmental matrices have been developed by many researchers, including chemiluminescence (Jansen *et al.*, 1985; Van Peteghem *et al.*, 1989), radioimmunoassay (Daeseleire *et al.*, 1991), gas chromatography-mass spectrometry (Bowden *et al.*, 2009), and liquid chromatography-mass spectrometry. However, most according methods have been developed for urine, hair, and other matrices.

Very few analytical method for environmental water and sediment samples were developed. Chang *et al.* (2008) have been developed the method of ultra-performance liquid chromatography–tandem mass spectrometry (UPLC–MS/MS) to analyze MT in wastewater samples. Liu *et al.* (2011) have been study analytical method for MT from surface water, wastewater and sludge using rapid resolution liquid chromatography–tandem mass spectrometry (RRLC–MS/MS). Huffer (2010) have been developed the method for analyzing MT from the masculinization pond's sediment of Nile tilapia fry using UPLC–MS/MS.

This study aims to investigate the occurrence of MT in masculinization pond of Nile tilapia fry and its discharged area.

1.2 Objectives

- To monitor MT in each compartment, water and suspended solids, and settled solids of Nile tilapia masculinization ponds and its discharged area along the hormone treatment period and post treatment period.

1.3 Hypotheses

MT may remain in each compartment of masculinization pond of Nile tilapia fry and its discharged area.

1.4 Scope of the Study

- Water (containing suspended solids) and settled solids were collected from Nile tilapia fry masculinization ponds.
- MT in water phase was extracted using solid phase extraction and MT in suspended solids and settled solids phases were extracted through liquid phase extraction.
- Concentration of MT was analyzed using Ultra performance liquid chromatography-tandem mass spectrometry (UPLC-MS/MS).
- MT in each phase was monitored during hormone treatment period for 21 days and post treatment period of 9 days.

CHAPTER II

LITERATURE REVIEW

2.1 Masculinization of Nile tilapia

According to the high consumption rate and market demand of Nile tilapia, the amount of tilapia product can be increased by producing all male population (Macintosh and Little, 1995). Male are preferred to female due to the double growth rate and larger body size. Consequently all male population is more popular than mixed population for most farmers (Penpan, 2004; Francesc 2001).

There are several methods to reverse sex of Nile tilapia such as manual sexing, interspecific hybridization, genetically supermale tilapia (YY male technology), and hormonal sex reversal such as using MT (Beardmore, 2001). Among several practices, hormonal sex reversal by using MT has been the common practice to induce the male sex for Nile tilapia due to high efficiency in sex reversing, convenient technique and low cost (Kuwaye *et al*, 1993; Penpan, 2004). MT is fed at the concentration about 60 mg per kilogram of feed to fry in masculinization ponds in beginning step of Nile tilapia's sex reversal for 28 consecutive days (Barry *et al*, 2007). More than 90% of fish can be reversed to be male after applying the hormone to Nile tilapia fry (Kriangsak *et al.*, 2006).

2.2 Endocrine disrupting chemicals

Kavlock (1991) has been defined endocrine disrupting chemicals as "exogenous agents that interfere the production, release, transport, metabolism, binding, action, or elimination of the substance in the body of an organism responsible for the maintenance of homeostasis and the regulation of developmental processes"

One of the most potential endocrine disrupting compounds found in environment is the chemicals in sort of steroids, both naturally generated by human and synthetically produced. Steroids are in the class of cholesterol. Structure of steroids were three hexagonal and one pentagonal carbon ring which contains different functional groups and side chains. Many studies concern about the occurrence of the estrogenic steroid hormones. The estrogenic steroids have been

discovered in aquatic environment which can deteriorate the wildlife (Sumpter and Johnson 2008). Additionally, the hormonal exposure of fish to municipal wastewater effluent caused the sex reversal from male to female at nanogram level (Purdom *et al*, 1994).

However, while estrogenic hormones have been widely considered, androgens have been recently taken in a role as one of the potential endocrine disrupting compounds. Although available known knowledge about androgens are scarce, but there still be the studied showed the effect of aquatic organisms downstream of pulp and paper mills resulted in androgenic exposure which was masculinization of female fish (Howell and Denton, 1989).

Androgens are C19 steroids which functions about the development of masculine characteristics. Androgenic hormones have residue in environment via wastewater treatment plants (WWTPs) which have been used as the growth promoters in both human and animal. The occurrence of androgenic or progestagenic steroids have been recently reported in the environment (Vulliet *et al*, 2008). A few researches have studied the masculinization of fish after the exposure at low concentration of nanogram per liter or pictogram per liter (Defraipont and Sorensen, 1993; Jenkins *et al*, 2001)

2.3 17 α - methyltestosterone (MT)

MT is an androgenic anabolic steroid which contains similar structure to the original androgen hormone, testosterone, which is different in the methyl functional group in the 17 position for MT. MT is used for oral form when testosterone is ineffective for this kind of use. Only 5- 10% of available testosterone get in the blood system because others are firstly destroyed at the liver but MT are not metabolized and broken down at the liver. MT is classified as the lower anabolic effect compare to testosterone.

The structure of 17 α - methyltestosterone (MT) and testosterone is illustrated in the following figure 2.1a and 2.1b respectively.

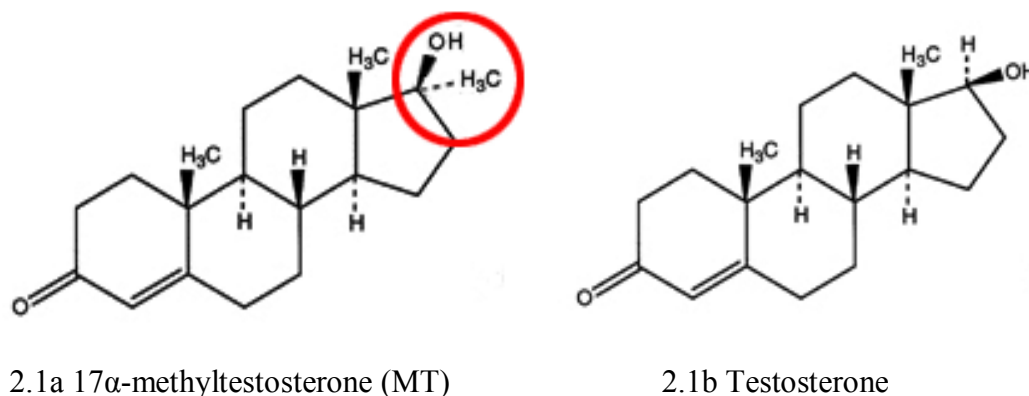

Figure 2.1 Structure of 2.1a 17 α -methyltestosterone (MT) 2.1b Testosterone

From the figures above, the different structure between MT and testosterone is the methyl functional group attached at the 17 position in MT.

Table 2.1 Physicochemical properties of 17 α -methyltestosterone

Property*	17 α -methyltestosterone
CAS ^c	58-18-4
Henry's constant ^b	4.68×10^{-9} atm m ³ /mole ²
Melting point ^c	163 °C
Molecular weight ^c	302.45 g/mole
Octanol/Water Partition Coefficient (Log K _{ow}) ^a	3.36
Water solubility @ 25°C ^c	3.39 mg/L
Vapor pressure ^c	1.85×10^{-8} mmHg

^a Hansch *et al.* (1995); ^b US EPA (2003); ^c Sigma-Aldrich material safety data sheet

According to the physicochemical properties of MT as described in Table 1, MT can be classified as a hydrophobic organic compound since the solubility of MT is low. MT may be likely to sorb in soil as the octanol/water partition coefficient is high.

2.4 Occurrence of MT in environment

There are a few studies reporting the occurrence of MT or its metabolites in Nile tilapia fry masculinization process. Fitzpatrick *et al.* (1999) investigated MT in water and soil samples by establishing a model pond using radioimmunoassay in order to determine MT concentration. This study reported that MT concentrations in water were highest at 14 and 21 days of treatment which were around 1 to 2 $\mu\text{g/L}$ and decreased to the background levels after one week of treatment. On the contrary, MT concentration in sediment were 1.4 and 1.7 $\mu\text{g/kg}$ at the end of hormonal treatment period and remained for three weeks at the concentrations of 0.8 and 1.6 $\mu\text{g/kg}$.

Fitzpatrick and Contreras-Sánchez (2000) seted the similar study with a larger container size and varied the compartments in the model pond (soil, gravel, or no soil) to determine MT concentration during hormone treatment period. MT concentrations in water were highest when no soil, followed by ponds containing soil, and concentrations in water were lowest for ponds containing gravel. Their findings revealed that sorption of MT has been significant mechanism. They also recommended that sediment kept MT and remaining for longer time. The remaining concentration in soil was around 2.8 and 2.9 $\mu\text{g/kg}$ for almost three months after ending the hormonal treatment period.

Huffer (2010) were monitored MT in two earthen nursery ponds during and after the treatment period. The results showed that MT were found in sediment at the concentration of $\mu\text{g/kg}$ -range.

2.5 Degradation of MT

Recently, Homkiln *et al.*, 2010, have determined the biodegradation of MT under different electron acceptors and the first order degradation rates for different electron acceptors' condition were determined. The results shows the biodegradation of MT occurred under methanogenic condition, sulfate-reducing condition, and aerobic condition and the first order degradation rates were $0.69 \pm 0.24 \text{ day}^{-1}$, $0.53 \pm 0.01 \text{ day}^{-1}$, $0.51 \pm 0.34 \text{ day}^{-1}$, respectively. While MT was degraded slowly under iron (III)-reducing with the first order degradation rate $0.007 \pm 0.00 \text{ day}^{-1}$ and MT was rarely degraded under nitrate-reducing conditions at the rate of $0.004 \pm 0.00 \text{ day}^{-1}$. Additionally, androgenic activities were measured, the findings have been found for the aerobic and sulfate-reducing bioassays were significantly reduced at the end of the experiment but for methanogenic condition, androgenic activity remained in the

bioassay for more than one month although the MT concentrations were degraded to lower level. This results may imply that MT and its products may persist in the environment under different environmental conditions.

For photodegradation, Budavari *et al.*, 1989, showed that MT is sensitive to UV- C which is 254 nm and weakly absorbs by UV- B. However, UV-C is absorbed in the atmosphere and does not reach to the ground. UV-B which has a wavelength of 280- 450 nm is the most sort of light that be responsible for the photodegradation of MT. According to following reasons, MT may be possible to treat by giving radiation at 254 nm rather than exposure to sunlight or UV-B. There is limited data for making decision whether UV is needed or not to remove MT or its metabolite.

2.6 Sorption

According to its physiochemocal properties, MT may tend to sorp on soil more than water due to the low octanol/water partitioning coefficient. Only study from Huffer in 2010. Studied that MT remained in soil at the concentration of $\mu\text{g/kg}$ after hormonal treatment period but there is no information about the amount of MT concentration in aqueous phase.

2.7 Effect of MT aquatic and terrestrial organisms

MT is questionable to be human carcinogen. Many studies revealed the effect of MT to many types organisms. Concentration of MT that may cause effect to the environment were in range of 6.4 ng/L to 110 mg/L. The summary level of MT and its effect is illustrated as shown in Table 2.2

Table 2.2 Active dosage levels and effects of MT to the various organisms

MT Dosage	Target	Effect	Reference
-	Liver	Inducing production of nonmalignant tumors in the liver	Soe <i>et al.</i> , 1992
6-9 mg of MT per day	Human prostate	Causing prostate cancer in human when exposed over a period of 30 years.	Nakata <i>et al.</i> 1997
10-500 ng/L	Female eelpout (<i>Zoarces viviparous</i>)	Decreasing the circulation of yolk-precursor protein vitellogenin that expresses the female characteristic	Korsgaard, 2006
100-1000 ng/L	Female freshwater ramshorn snail (<i>Marisa cornuarietis</i>)	Stimulating imposex for the development of male sex organs such as penis and vas deferens when exposed for 6 months	Oehlmann <i>et al.</i> , 2004
46.8 ng/L	Adult medaka fish	Decreasing the fecundity and fertility of paired medaka	Kang <i>et al.</i> , 2008
-	Common crap (both male and female) and rainbow trout	Inhibiting the production of testosterone hormone	Fitzpatrick <i>et al.</i> , 1993
6.4 and 8.5 ng/L	Adult male zebrafish (<i>Danio rerio</i>)	Decreasing 11-ketotestosterone and testosterone levels to the lowest effective level	Anderson <i>et al.</i> , 2006
50-110 mg/L	Japanese quails (<i>Coturnix cotumix japonica</i>)	Decreasing egg-laying rate female and the fertility in male when exposed for 3 weeks	Selzsam <i>et al.</i> , 2005

2.8 Determination of MT

Many analytical techniques have been recently developed to determine the steroid which remain in environment. Kolodziej *et al.* (2003) applied Gas

chromatography–mass or tandem mass spectrometry, GC–MS(/MS), to analyze two androgens and one or two progestogens in the wastewater effluents and also surface water samples. (Kolodziej & Sedlak, 2007). However, some androgens, such as stanozolol, were proved that they did not able to be derivatized. Then, LC–MS(/MS) is an approaches to analyze androgens in wastewater and surface water samples without derivatization required, and also provided more sensitivity and specificity, without any need for derivatization (Yamamoto *et al*, 2006). However, the two methods explained above were measured only four progestogens and five androgens.

Chang *et al.* (2008) have been developed the method of ultra- performance (UPLC–MS/MS) to analyze nine androgens and progestogens in wastewater samples. MT was extracted from samples using solid phase extraction through Oasis HLB and MT concentration was determined using UPLC-MS/MS. Detection limit was at 1 ng/L and percent recovery was at 84 %.

Liu *et al.* (2011) have been studymethod for extraction 28 steroid including estrogens, androgens, progestagens and glucocorticoids using solid phase extraction through silica gel cleanup and ultrasonic extraction for water and sediment samples, respectively. Concentration of MT was analyzed using rapid resolution liquid chromatography–tandemmass spectrometry (RRLC–MS/MS). For water samples, percent recoveries were found to 88 % to 101 % LOD was 0.01 ng/L to 0.79 ng/L. LOQ was 0.04 ng/L to 0.24 ng/L. MT were found to 0.8 ng/L to 1.8 ng/L. For sludge samples percent recoveries were found to 76 % to 88 %. LOD was 0.37 ng/g. LOQ was 1.24 ng/g. No MT was found in real sludge samples.

In terms of determination of MT concentration in sediment, study from Huffer (2010) have been developed the method for analyzing MT concentration in sediment by using liquid phase extraction to extract MT from samples and using UPLC–MS/MS to analyze. MT concentration in sediment were determined with the percent recovery about 97 % for using methanol as an extraction solvent.

CHAPTER III

METHODOLOGY

3.1 Experimental Framework

The methodology of this study can be summarized by the experimental framework as shown in figure 3.1

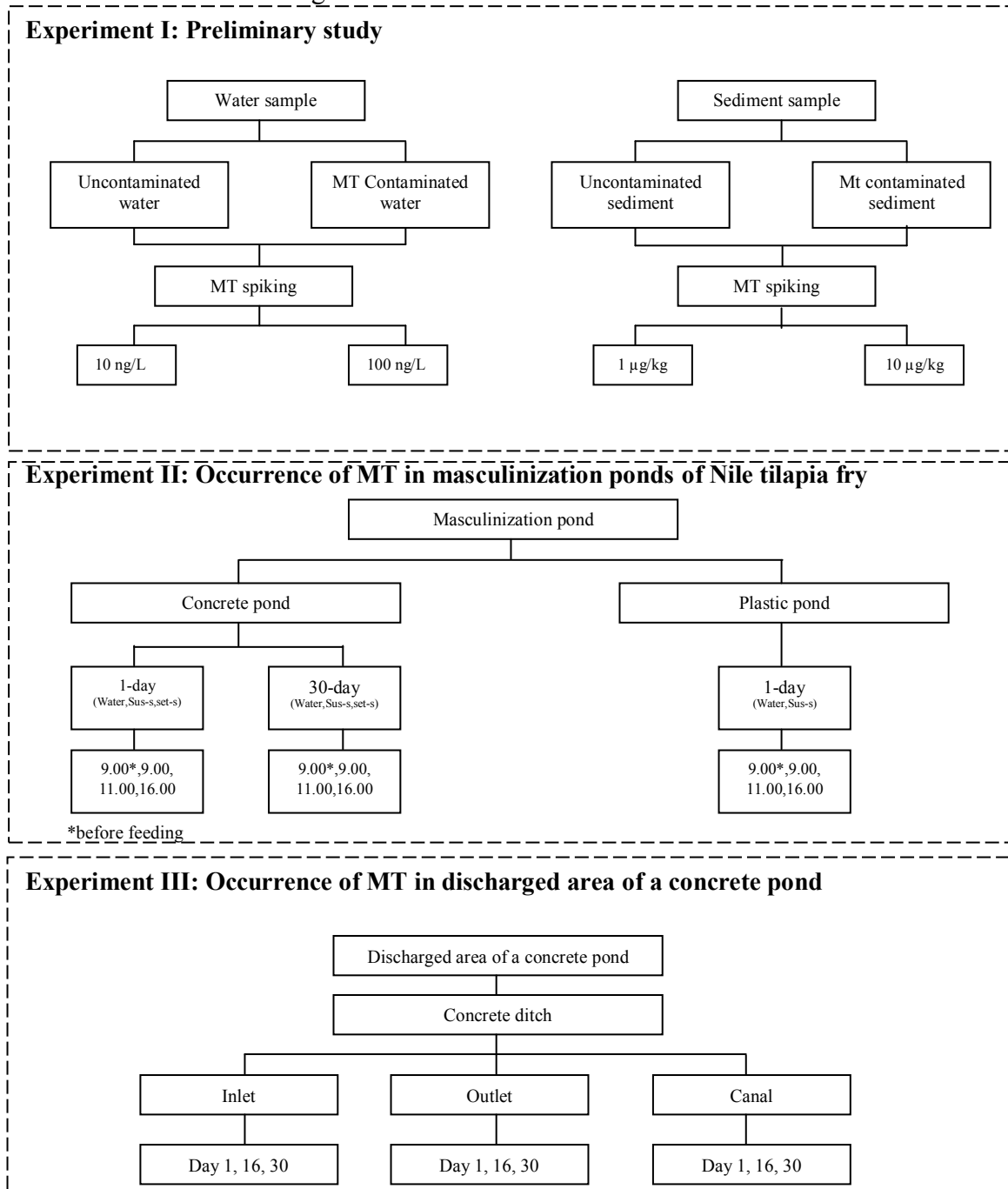

Figure 3.1 Experimental framework

3.2 Materials

MT (>99% pure, HPLC grade, Fluka, Butch, Switzerland) stock solution was prepared at a concentration of 10 mg/L in methanol (> 99% pure, analytical grade, MI, USA) and kept in -20°C. Two working solutions of 10 µg/L and 100 µg/L were prepared by diluting 0.1 mL and 1 mL of the stock solution in 99.9 mL and 99 mL methanol, respectively. Standard solutions for MT were prepared from the working solutions and the standard curves were constructed in every set of experiment.

3.3 Description of site and masculinization process of Nile tilapia fry

Nile tilapia farm was selected and the layout of the farm is shown in figure 3.3. The masculinization process was performed in two different types of ponds, concrete and plastic ponds (figure 3.2a and 3.2b, respectively). The hormone treatment was separately applied for each individual pond.

One kg of feed containing 60 mg of MT was applied to Nile tilapia fry for 21 days after 8 to 13 day post fertilization. The feed was supplied 4 times a day at 9.00, 11.00, 13.00, and 16.00. After 21 days the fry were fed with the feed containing no MT. On day 30, the fry were moved and grew in an earthen growth pond. The masculinization pond was then cleaned and prepared for the next batch of hormone treatment.

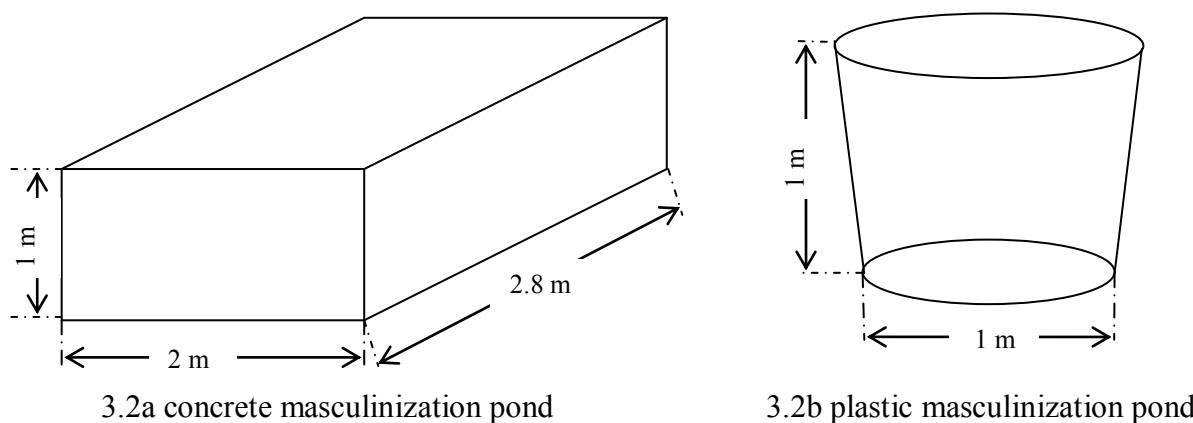

Figure 3.2 Schematic of 3.2a concrete masculinization pond

3.2b plastic masculinization pond



Figure 3.3 Layout of Nile tilapia farm

During 30 days of operation, fresh water was supplied daily at the rate of approximately 2000 L/d. For plastic masculinization pond, fresh water flew into the round plastic tanks with a diameter of 1 meter and 1 meter in height. The overflow water (containing water and suspended solids) was released through the earthen drainage connecting to the earthen growth pond. Part of the water in the earthen growth pond was passed to the raw water pond which was used for masculinization process after passing through a sand filtration system. For concrete masculinization pond, fresh water flew into the rectangular concrete ponds with 2 meters in width, 2.8 meters in length and 0.5 meters in depth. The overflow water from the concrete ponds was released through the concrete ditch connecting to the natural canal.

On day 30, water containing suspended solids as well as settle solids at the bottom of the masculinization ponds was released through the earthen drainage ditch. The schematic diagram of Nile tilapia masculinization area is illustrated in Figure 3.4.

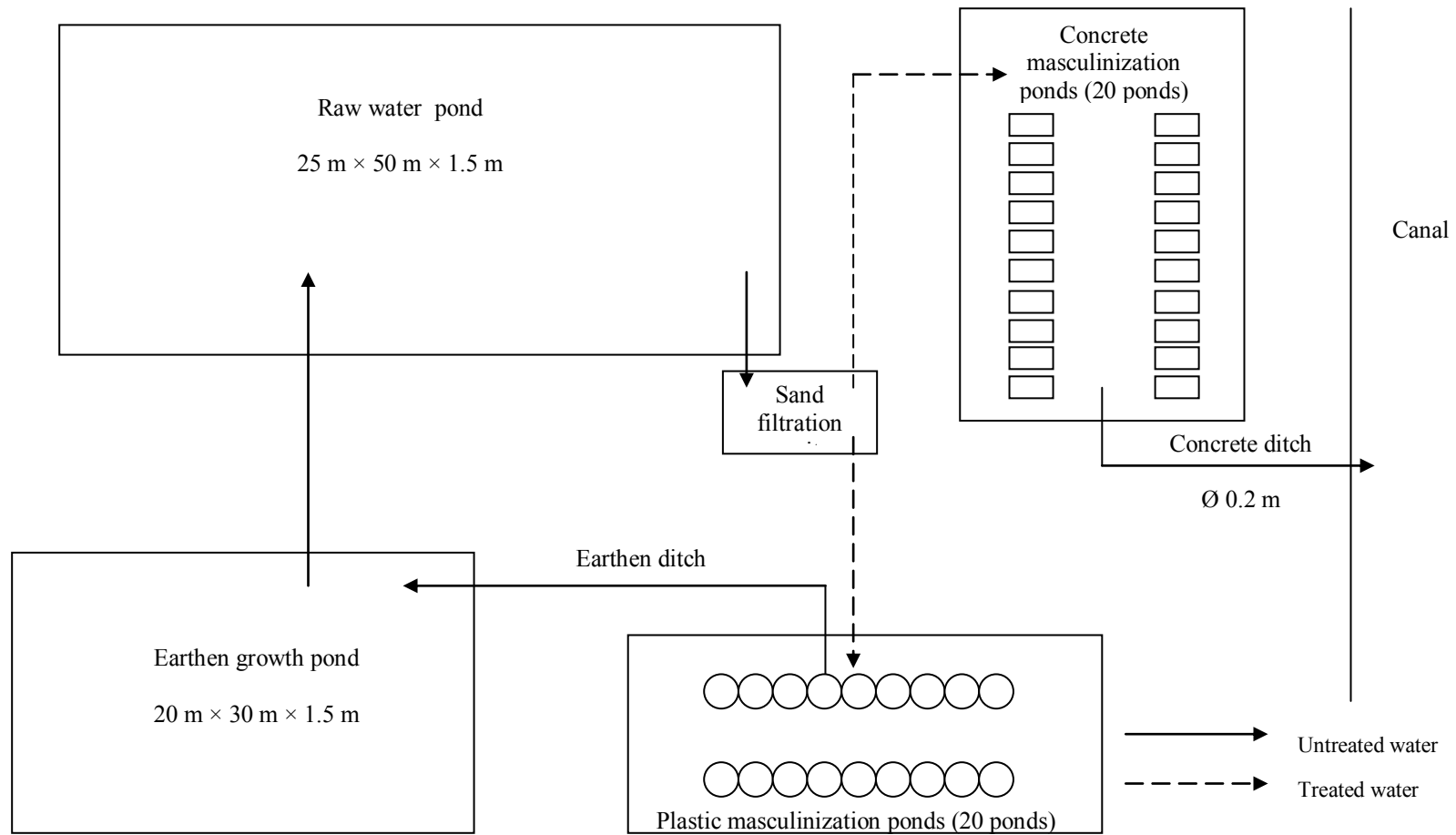

Figure 3.4 Schematic diagram of Nile tilapia masculinization area

3.4 Experiment 1: Preliminary study

The analysis of MT in water and sediment samples was separated in two parts including extraction of MT from water and sediment samples and determination of MT concentration.

3.4.1 Extraction of MT from water and sediment samples

Water sample

Water sample was filtered through a glass microfiber filter GF/F 0.7 μ m (Whatman, Maidstone,UK). MT was extracted through an Oasis HLB cartridge (6 mL, 500 mg, Waters, Milford, MA, USA), which was preconditioned with 6 mL of ethylacetate, 6 mL of acetonitrile, and 12 mL of millipore water. Then, cartridge was loaded with 1000 mL filtrated sample at a flow rate of 2 mL/min. After the cartridge was washed with 10 mL of millipore water, MT was eluted from the cartridge with 15 mL ethylacetate. The solvent volume was dry by evaporation in a water bath at 55 °C under a gentle flow of nitrogen. Then the extract was re-solved in 1 mL methanol.

Sediment sample

In 2010, Huffer developed a method for Liquid-phase extraction (LPE) of MT from sediment samples. Sediment sample was dried, grinded and sieved through the US Sieve Size 60 (250 μ m). 5 g of sieved sediment was placed into 50 mL- Oak Ridge Centrifuge Tubes (Nalgene Labware, USA). Sample was extracted three times with methanol. For each extraction, sample and 10 mL of methanol were mixed completely using vortex. (Scientific Industries Inc, Bohemia, NY, USA), followed by sonicated with sonicator (Elma, Singen, Germany) for 15 minutes and centrifuged using high speed centrifuge (Hanau, Germany) at 8,000 rpm for 10 min. The supernatant was collected and mixed. Then, the sediment extract was evaporated to near dryness at 55 °C. Then the extract was re-solved in 1 mL methanol and was filtered through 0.45 μ m Mini-Uniprep™ PVDF filter media with propylene housing (Whatman, USA).

3.4.2 Determination of MT concentration

MT concentration in the extract was determined using Ultra performance liquid chromatography-tandem mass spectrometer (UPLC-MS/MS).

Ultra performance liquid chromatography-tandem mass spectrometer

Each extracted solution was determined for MT concentration using a ZORBAX Eclipse Plus C18 column (rapid resolution HD, 50 mm ×2.1mm, 1.8 μm particle size, Agilent, USA). The column was maintained at 60°C at a flow rate of 0.15 mL/min, and the injection volume was 5 μL. ACN containing 0.1% formic acid and water containing 0.1% formic acid, were used as the mobile phases. The conditions for UPLC column were with 60% of ACN containing 0.1% formic acid, and 40% of water containing 0.1% formic acid with run time 2.5 minute. Mass spectrometry was performed using a Waters TQ detector which operated with ESI in the +ve mode. The detection conditions of the mass spectrometer were as follows: capillary voltage, 2500 V; nozzle voltage, 1000 V; gas flow, 19 L/min; sheath gas flow, 12 L/h; nebulizer pressure, 50 psi; gas temperature, 300 °C; sheath gas temperature, 400°C. Eventually, the extracted water samples were subjected UPLC-MS/MS for MT analysis.

3.4.3 Recovery test

Deionized water and masculinization pond water were selected for the extraction method. MT was spiked in 1000 mL of the water samples at the levels of 10 ng/L, and 100 ng/L in 1000 ml of water samples. Water samples were extracted and determined for MT concentrations following the method described in section 3.4.1 and 3.4.2. This extraction method can concentrate the extracted sample 1000 times. Therefore, 10 μg/L, and 100 μg/L of MT standard were prepared to set the standard curve.

Uncontaminated-MT sediment and masculinization pond sediment were used to assess accuracy of the extraction method. MT was spiked to the 5 g sediment samples at the level of 1 μg/kg, and 10 μg/kg. Sediment samples were extracted and determined for MT concentrations following the method described above. The extraction method for sediment can concentrate the extracted sample 10 times of initial concentration. Thus, 10 μg/L, and 100 μg/L of MT matrix's standard were prepared to construct standard curve. The matrix's standards were prepared by extraction 5 g of uncontaminated-MT sediment without spiking MT following the method for sediment. The extracted solution were then spiked with MT working solution to get the concentration at 10 μg/L, and 100 μg/L.

3.5 Experiment II: Occurrence of MT in masculinization process of Nile tilapia fry

3.5.1 Mass flow of MT in masculinization pond

Mass flow of MT in the controlled boundary of each masculinization pond is shown according to Figure 3.5

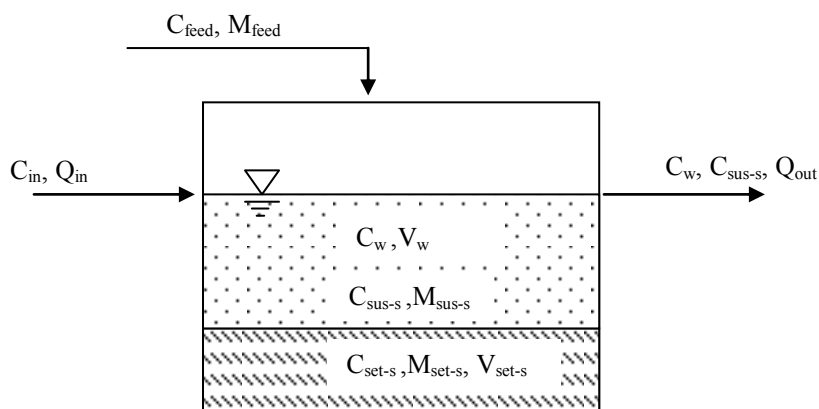

Figure 3.5 Schematic diagram of masculinization pond of Nile tilapia fry

Where,

- C_{feed} = Concentration of MT in the feed (mg/kg)
- M_{feed} = Amount of feed daily supplied (kg)
- C_{in} = Concentration of MT in influent water (ng/L)
- Q_{in} = Flow rate of the influent water (L/d)
- C_{sus-s} = Concentration of MT in suspended solids ($\mu\text{g/kg}$)
- M_{sus-s} = Mass of suspended solids (mg/L)
- C_w = Concentration of MT in the water in the pond (ng/L)
- V_w = Volume of pond water (L)
- C_{set-s} = Concentration of MT in settled solids ($\mu\text{g/kg}$)
- M_{set-s} = Mass of settled solids (mg/L)
- V_{set-s} = Volume of settled solids (L)
- Q_{out} = Flow rate of the overflow water (L/d)

$$MT_{input} = MT_{overflow} + MT_{in\ pond} + MT_{reaction} \dots \dots \dots \text{Equation 3.1}$$

$$C_{in} Q_{in} + C_{feed} M_{feed} = (C_w Q_{out} + C_{sus-s} M_{sus-s} Q_{out}) + (C_w V_w + C_{sus-s} M_{sus-s} V_w + C_{set-s} M_{set-s} V_{set-s}) + MT_{reaction}$$

Where, $C_{in} = 0$

Therefore,

$$C_{\text{feed}} M_{\text{feed}} = (C_w Q_{\text{out}} + C_{\text{sus-s}} M_{\text{sus-s}} Q_{\text{out}}) + (C_w V_w + C_{\text{sus-s}} M_{\text{sus-s}} V_w + C_{\text{set-s}} M_{\text{set-s}} V_{\text{set-s}}) + MT_{\text{reaction}}$$

Input term was the amount of MT fed together with feed into the masculinization pond ($C_{\text{feed}}, M_{\text{feed}}$). An output term was the amount of MT in the overflow water released to the concrete ditch ($C_w Q_{\text{out}} + C_{\text{sus-s}} M_{\text{sus-s}} Q_{\text{out}}$). MT in water was found in two phases: water phases and suspended solids phase. And the in pond term was MT remaining in the pond ($C_w V_w + C_{\text{sus-s}} M_{\text{sus-s}} V_w + C_{\text{set-s}} M_{\text{set-s}} V_{\text{set-s}}$). It existed in three compartments: water, suspended solids and settled solids. In this study, we do not account for the in reaction term which include uptake by the fry, excrete by the fry, biotic degradation, abiotic degradation, and etc.

3.5.2 Sample collection

Water containing suspended solids were collected from 9 points in the masculinization pond and mixed completely in 1000 mL bottle. Settled solids sample was collected from 3 points at the bottom of the masculinization pond. The points for sample collection are shown in figure 3.6. Each sample was mixed completely, maintained at pH 2 and kept in 4° C.

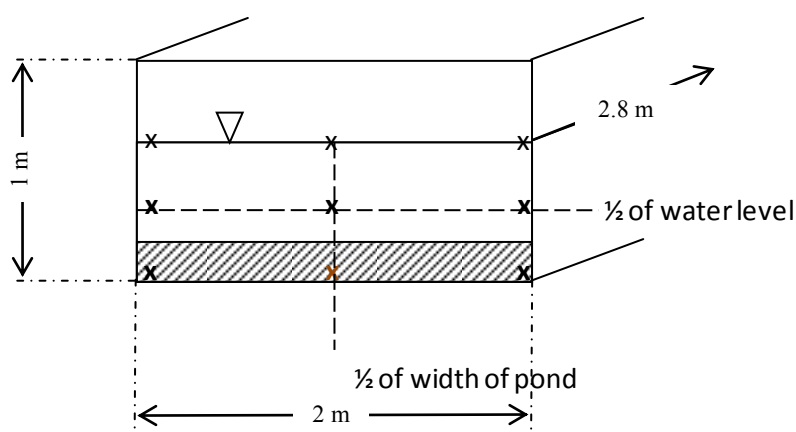

Figure 3.6 Sample collecting points in concrete masculinization pond

One liter of water containing suspended solids was filtrated using glass microfiber filters GF/F 0.7 μ m (Whatman, Maidstone,UK). The water phase was extracted and determined for MT concentration following the method described in section 3.4.1 and 3.4.2. The suspended solid phase was fixed on the glass microfiber filters, dried at 110° C and

placed into 50 mL- Oak Ridge Centrifuge Tubes. The suspended solid and settled solid samples were extracted and determined for MT concentrations following the method for sediment as described in section 3.4.1 and 3.4.2.

3.5.3 One- day monitoring

Sample in each compartment, comprising of water containing suspended solids and settled solids at the bottom of the ponds were taken at the day 7 of hormone treatment operation from both types of ponds (plastic and concrete masculinization ponds) at 9.00 before feeding, 9.00 after feeding, 11.00 after feeding, and 16.00 after feeding to observe the change in MT concentrations along the day and define the time that MT reached the maximum level. Samples were collected as shown in Table 3.1.

Table 3.1 Sampling schedule during 1- day monitoring

Type of ponds	Time	Sample		
		Water	Sus-s	Set-s
Plastic	9.00 before feeding	✓	✓	-
	9.00 after feeding	✓	✓	-
	11.00 after feeding	✓	✓	-
	16.00 after feeding	✓	✓	-
Concrete	9.00 before feeding	✓	✓	✓
	9.00 after feeding	✓	✓	✓
	11.00 after feeding	✓	✓	✓
	16.00 after feeding	✓	✓	✓

3.5.4 30- day monitoring

Nile tilapia fry was induced to exhibit male sex by feeding the feed mixed with MT (60 mg MT per kg feed) for 21 days and the fry was then raised with the feed without MT until day 30 before moved to the earthen growth pond. Every day, clean water was supplied into the masculinization pond at the flow rate of approximately 2000 L/d to control water temperature in the masculinization pond. Therefore the overflow water with the corresponding flow rate released from the masculinization pond to the concrete ditch connected to the earthen channel. After MT was applied into the masculinization pond, it appeared in three compartments comprising of water phase, suspended solids phase, and settled solids. MT mass flow is illustrated according to equation 3.1.

Amount of MT in feed

The amount of MT in feed was calculated from the concentration of MT in the feed (C_{feed}) and the amount of feed (M_{feed}) supplied. In the masculinization process, C_{feed} was 60 mg/kg of feed for the whole period of masculinization of 21 days. Daily amount of feed varied depending on the weight of the fry and duration of the process. During the first week, Nile tilapia fry was fed with the feed at the amount 20 % of the fry weight. The amount of feed was reduced to 15 % and 10 % of the fry weight for the second and third weeks, respectively (Phelps and Popma, 2000). The daily total weight of fry were measured for 30 days.

Amount of MT in overflow water

During Nile tilapia fry masculinization process, water containing suspended solids overflow into the concrete ditch. The amounts of MT in the water phase of the overflow can be calculated from the concentrations of MT in the water phase (C_w) and the overflow flow rate (Q_{out}). The amounts of MT in the suspended solids phase of the overflow can be computed from the concentrations of MT in suspended solids phase ($C_{\text{sus-s}}$), concentrations of suspended solids in overflow water ($M_{\text{sus-s}}$), and the overflow flow rate (Q_{out}). C_w , $C_{\text{sus-s}}$ and $M_{\text{sus-s}}$ were monitored by collecting the water containing suspended solids and determined for MT concentrations on each compartment (water and suspended solids). Water and suspended solids were collected to observe MT in overflow as shown in Table 3.2.

Table 3.2 Sampling schedule for observation of MT in overflow water during 30 days

Day	Sample	
	Water	Sus-s
1	✓	✓
7	✓	✓
11	✓	✓
16	✓	✓
21	✓	✓
30	✓	✓

Amount of MT remaining at the end of operation (day 30)

On day 30, the masculinization pond was cleaned and the remaining MT in water containing suspended solids and settled solids was released into the concrete ditch. The amount of MT remaining in the water phase was calculated from the concentration of MT in the water (C_w) and the volume of the water (V_w). The amount of MT in the suspended solids phase was computed from the concentration of MT in suspended solids ($C_{\text{sus-s}}$), concentration of suspended solids ($M_{\text{sus-s}}$), and volume of water (V_w). The amount of MT in the settled solids was calculated from the concentration of MT in the settled solids (C_{set}), concentration of settled solids (M_{set}), and the volume of settled solids (V_{set}). Water, suspended solid, and settled solids were collected at the end of day 30 as shown in Table 3.3.

Table 3.3 Schedule for observation of MT remaining in the ponds at the end of operation (day 30)

Parameter	Sample		
	Water	Sus-s	Set-s
Concentration	✓	✓	✓
Mass (mg/L)	-	✓	✓
Volume (L)	✓	-	✓

3.6 Experiment III: Occurrence of MT in discharged area of concrete ponds

Overflow water from all 20 concrete masculinization ponds flowed through the 40-m-long concrete ditch and released into the earthen canal. Water samples containing suspended solids as well as settled solids samples were taken from three different positions (figure 3.7). Two positions were at the inlet (position 1) and outlet (position 2) of the 20-m-long concrete ditch. The third position was in the earthen canal at the point receiving discharge from the concrete ditch (position 3). Samples were taken on day 1, 16, and 30 as shown in Table 3.4.

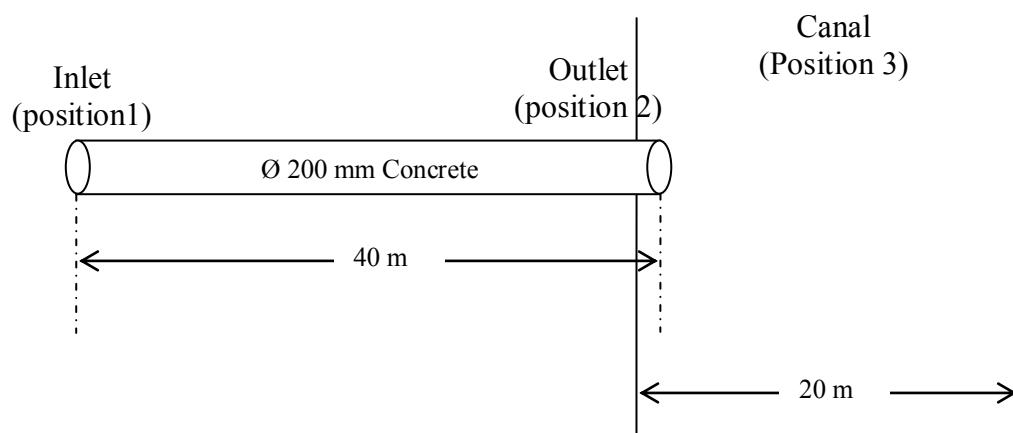

Figure 3.7 Schematic diagram of discharged area

Table 3.4 Sampling schedule for occurrence of MT in discharged area

Day	Position	Sample		
		Water	Sus-s	Set-s
1,16,30	1	✓	✓	✓
	2	✓	✓	✓
	3	✓	✓	✓

CHAPTER IV

RESULTS AND DISCUSSION

4.1 Preliminary study

Chang et al. (2008) have recently performed a trace analysis study of androgens and progestogens in environmental water samples using SPE. Percent recovery of MT in spiked water sample at concentration level of 0.005 ng/L to 100 ng/L was more than 80 %.

Uncontaminated water (deionized water) and masculinization pond water were selected for this study. MT was spiked in 1000 mL water samples at levels of 10 ng/L, 100 ng/L and 1000 ng/L. Triplicates of each concentration were performed. MT were extracted from water samples using SPE and MT concentrations were examined using UPLC-MS/MS for the spiked samples at concentrations level of 10 ng/L and 100 ng/L and using HPLC for the spiked samples at a concentration level of 1000 ng/L. Laboratory blank was performed to confirm that there was no contamination during extraction method. Standards were prepared by diluting MT working solution to obtain concentration level at 10 ng/L, 100 ng/L, and 1000 ng/L in methanol.

For deionized water, average concentrations of MT in spiked samples at the concentration levels of 10 ng/L, 100 ng/L, and 1000 ng/L were 8.02 ng/L, 82.30 ng/L, and 926.64 ng/L, respectively. Percent recoveries of the MT in spiked samples were 80.16 %, 82.30 %, and 92.66 %, respectively. For masculinization pond water samples, average concentrations of MT in spiked samples at the level of 10 ng/L, 100 ng/L, and 1000 ng/L were 8.01 ng/L, 83.37 ng/L, and 917.28 ng/L, respectively. Percent recoveries of the MT in spiked samples were 80.18 %, 82.37 %, and 91.73 %, respectively. The method's accuracy was assessed by calculating the percent of recovery from laboratory control samples. Average concentration and percent recoveries of each concentration level were shown in Table 4.1.

Table 4.1 Concentration and percent recovery of MT in spiked water sample

Sample	Spiked conc. (ng/L)	Replicate	C _{UPLC} (µg/L)	Factor	C _w (ng/L)	Blank conc. (ng/L)	% recovery	Avg. C _w (ng/L)	Avg. % recovery
DI water	10	1	9.3	0.001	9.3	0	92.76	8.0 ± 1.1	80.16 ± 11.03
		2	7.5	0.001	7.5	0	75.46		
		3	7.2	0.001	7.2	0	72.25		
	100	1	79.0	0.001	79.0	0	79.04	82.3 ± 2.9	82.31 ± 2.95
		2	83.1	0.001	83.1	0	83.12		
		3	84.8	0.001	84.8	0	84.77		
Pond water	10	1	8.1	0.001	8.1	0	80.89	8.0 ± 0.1	80.19 ± 0.96
		2	8.1	0.001	8.1	0	80.59		
		3	7.9	0.001	7.9	0	79.09		
	100	1	85.2	0.001	85.2	0	85.22	84.4 ± 1.1	84.37 ± 0.11
		2	83.1	0.001	83.1	0	83.11		
		3	84.8	0.001	84.8	0	84.77		

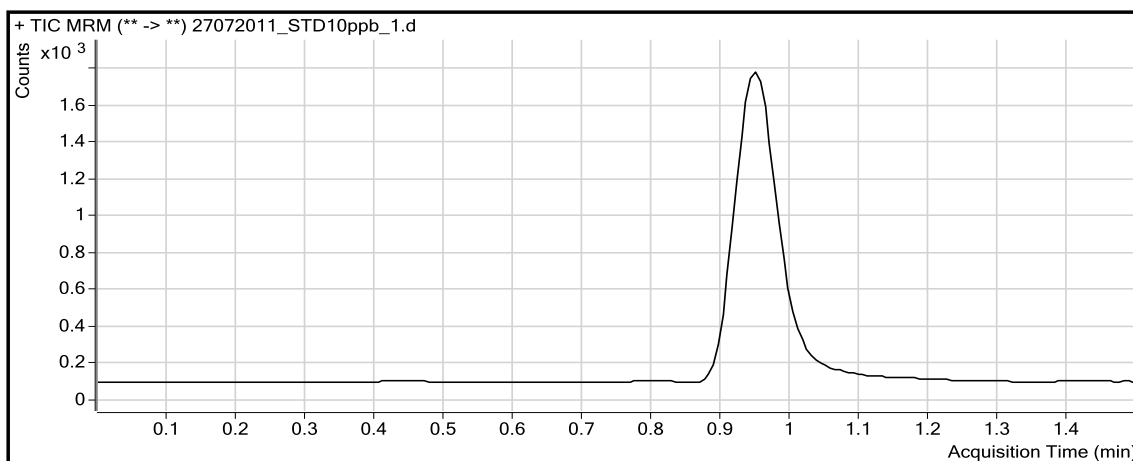

Figure 4.1 Chromatogram of standard 10 ppb of 17 α -methyltestosterone

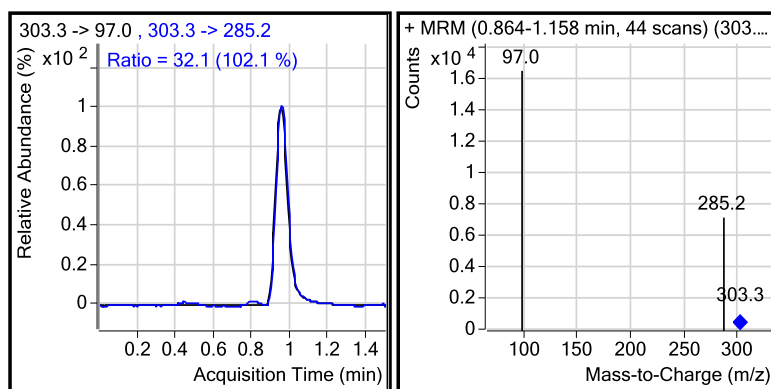

Figure 4.2 Mass spectrometry data of standard 10 ppb of 17 α -methyltestosterone

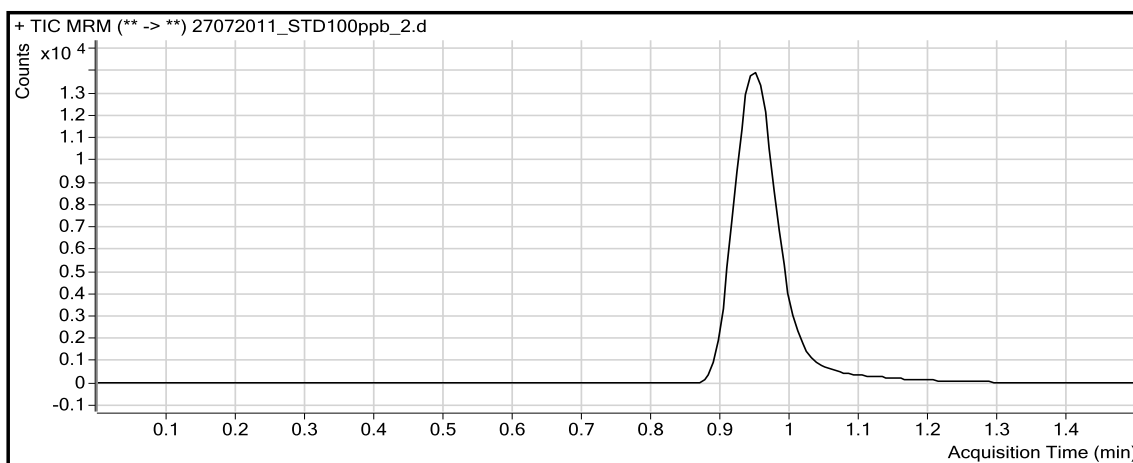

Figure 4.3 Chromatogram of standard 100 ppb of 17 α -methyltestosterone

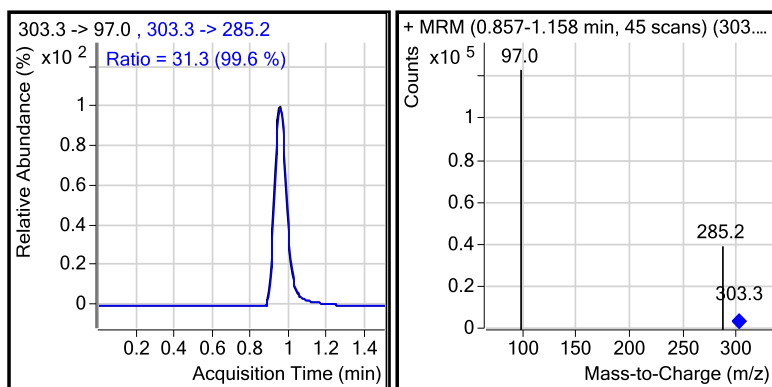

Figure 4.4 Mass spectrometry data of standard 100 ppb of 17 α -methyltestosterone

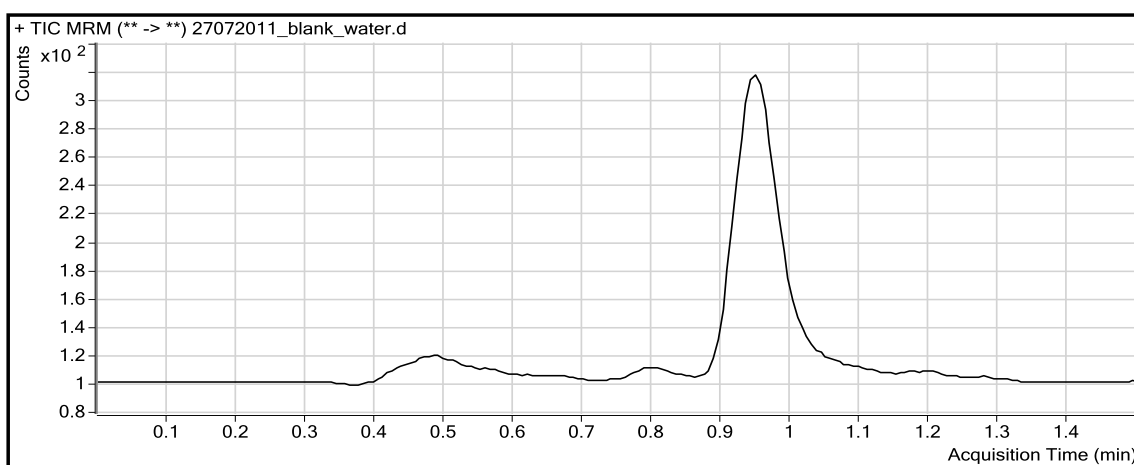

Figure 4.5 Chromatogram of blank water sample

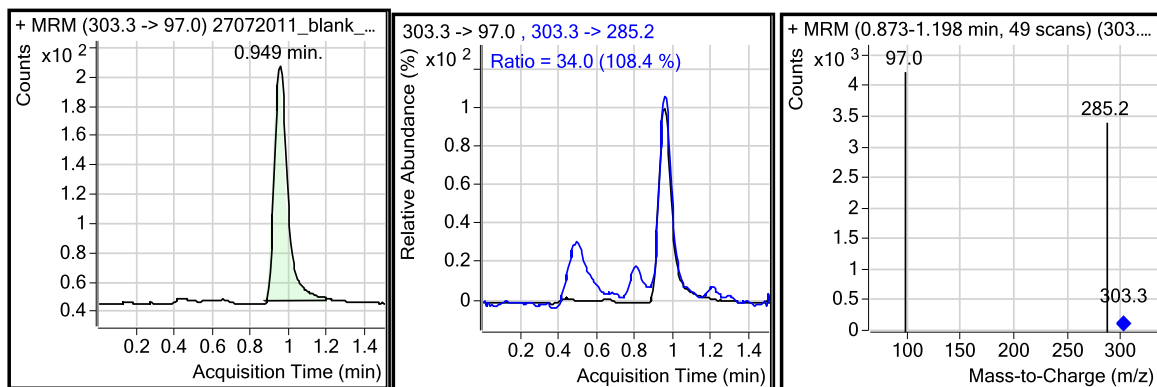

Figure 4.6 Mass spectrometry data of blank water sample

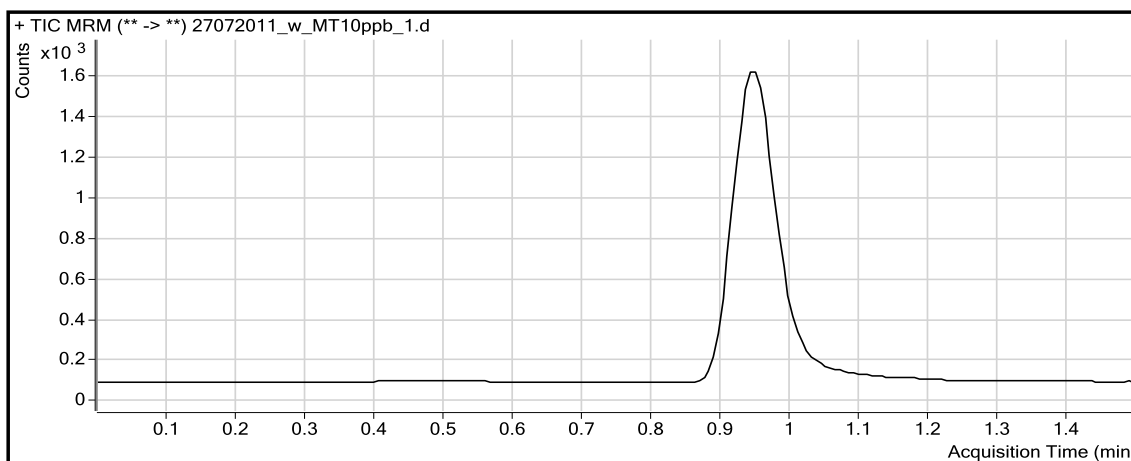

Figure 4.7 Chromatogram of DI water sample spiked 10 ng/L of 17α -methyltestosterone

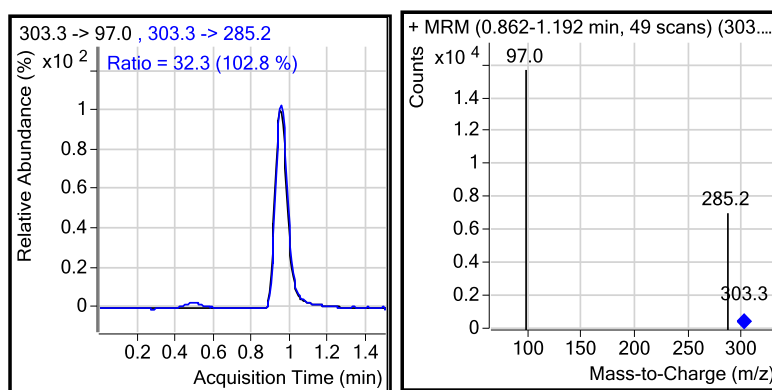

Figure 4.8 Mass spectrometry data of DI water sample 10 ng/L of 17α -methyltestosterone

The extraction method of MT from sediment samples was prior developed by Huffer *et al.* in 2010. LPE using methanol as extraction solvent was performed and the percent recovery was found to be 97.01 %. MT uncontaminated sediment and masculinization pond sediment were selected in this study. 5 g of sediment sample was spiked with MT at levels of 1 $\mu\text{g}/\text{kg}$, 10 $\mu\text{g}/\text{kg}$ and 100 $\mu\text{g}/\text{kg}$. Triplicates of each concentration were performed. MT were extracted from the sediment samples using LPE and MT concentrations were analyzed using UPLC-MS/MS for the spiked samples at level of 1 $\mu\text{g}/\text{kg}$, and 10 $\mu\text{g}/\text{kg}$ and using HPLC for the spiked samples at level of 100 $\mu\text{g}/\text{kg}$. Laboratory blank was extracted to confirm that there was no contamination during extraction method. For MT uncontaminated sediment, average concentrations of MT in spiked samples at the levels of 1 $\mu\text{g}/\text{kg}$, 10 $\mu\text{g}/\text{kg}$ and 100 $\mu\text{g}/\text{kg}$, were 0.69 $\mu\text{g}/\text{kg}$, 6.06 $\mu\text{g}/\text{kg}$, and 75.39 $\mu\text{g}/\text{kg}$, respectively. Percent recoveries of MT in the spiked samples were 69.44 %, 60.58 %, and 75.39 %, respectively. For masculinization pond sediment, average concentrations of MT in spiked samples at the

level of 1 $\mu\text{g}/\text{kg}$, 10 $\mu\text{g}/\text{kg}$ and 100 $\mu\text{g}/\text{kg}$ were 6.10 $\mu\text{g}/\text{kg}$, 71.00 $\mu\text{g}/\text{kg}$, and 686.50 $\mu\text{g}/\text{kg}$, respectively. Percent recoveries of MT in the spiked samples were 60.10 %, 71.00 %, and 68.65 %, respectively. The method's accuracy was assessed by calculating the percent of recovery from laboratory control samples. Average concentration and percent recoveries of each concentration level were shown in Table 4.2.

Table: 4.2 Concentration and percent recovery of MT in spiked sediment sample

Sample	Spiked conc. ($\mu\text{g/L}$)	Replicate	C_{UPLC} ($\mu\text{g/L}$)	Factor	C_{sed} ($\mu\text{g/kg}$)	Blank conc. ($\mu\text{g/kg}$)	% recovery	Avg. C_{sed} ($\mu\text{g/kg}$)	Avg. % recovery
Uncontaminated-MT sediment	1	1	5.10	0.1	0.51	0	50.98	0.69 ± 0.16	69.02 ± 16.09
		2	8.19	0.1	0.82	0	81.88		
		3	7.42	0.1	0.74	0	74.21		
	10	1	61.09	0.1	6.11	0	61.09	6.06 ± 0.44	60.58 ± 4.36
		2	64.66	0.1	6.47	0	64.66		
		3	55.98	0.1	5.60	0	55.98		
Contaminated-MT sediment	1	1	6.54	0.1	0.65	0	65.44	0.61 ± 0.04	60.99 ± 4.26
		2	6.06	0.1	0.61	0	60.58		
		3	5.70	0.1	0.57	0	56.95		
	10	1	64.66	0.1	6.47	0	64.66	7.10 ± 0.5	71.00 ± 5.73
		2	75.80	0.1	7.58	0	75.80		
		3	72.54	0.1	7.25	0	72.54		

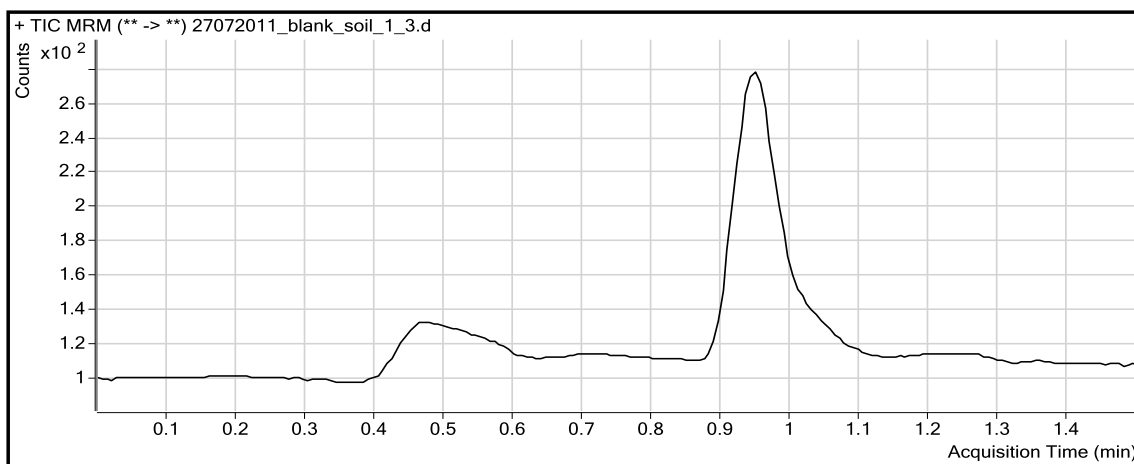

Figure 4.9 Chromatogram of blank sediment sample

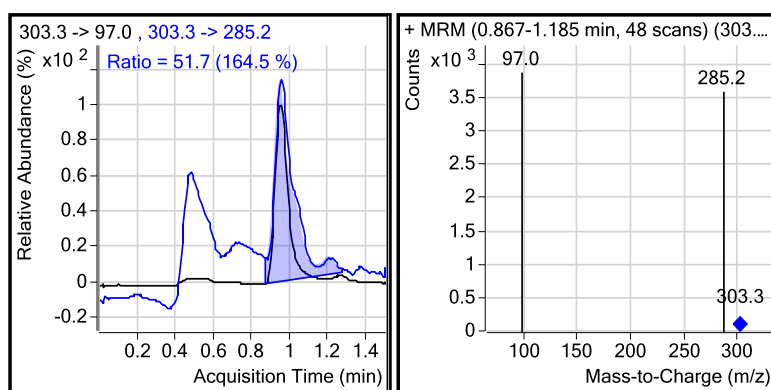

Figure 4.10 Mass spectrometry data of blank sediment sample

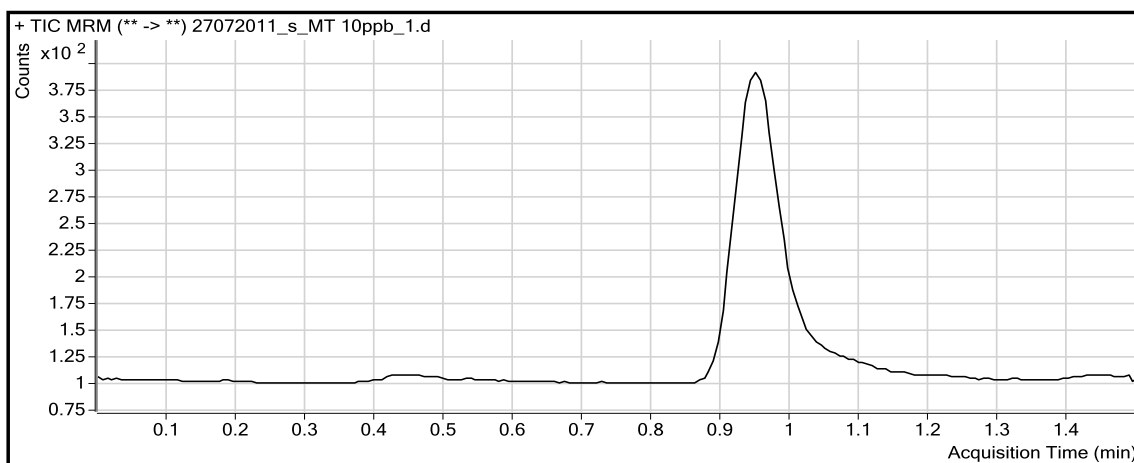

Figure 4.11 Mass spectrometry data of uncontaminated MT sediment sample spiked 1 $\mu\text{g/L}$ of 17 α -methyltestosterone

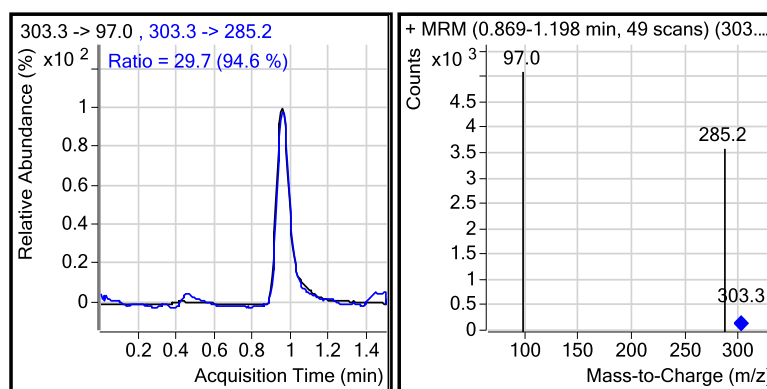

Figure 4.12 Chromatogram of uncontaminated MT sediment sample spiked 1 $\mu\text{g/L}$ of 17 α -methyltestosterone

4.2 Occurrence of MT in of masculinization process of Nile tilapia fry

4.2.1 One- day monitoring

Nile tilapia fry were fed with feed mixed with MT 4 times a day at 9.00, 11.00, 13.00 and 16.00. Samples in each compartment, comprising of water containing suspended solids and settled solids at the bottom of the pond were taken at the day 7 of hormone treatment operation from both types of ponds (plastic and concrete masculinization ponds) at 9.00 before feeding, 9.00 after feeding, 11.00 after feeding, and 16.00 after feeding (to observe the change in MT concentrations along the day and define time that MT reaches to the maximum concentration level).

Plastic masculinization pond

Water samples (containing water phase and suspended solids phase) were collected from the plastic masculinization pond. MT concentrations separately found in the water phase and suspended solid phase after filtrated through a glass microfiber filter GF/F 0.7 μm as described in section 3.4.1. Table 4.3 shows the concentrations of MT in water and suspended solid phase of plastic masculinization pond during 1 day. The concentrations in the water phase at 9.00 before feeding, 9.00 after feeding, 11.00 after feeding, and 16.00 after feeding were 2.5 ± 0.0 ng/L, 5.3 ± 0.0 ng/L, 9.4 ± 0.5 ng/L, and 25.7 ± 2.1 ng/L, respectively (Figure 4.13). MT concentrations in the water compartment slightly increased with the feeding times. The maximum MT concentrations in water compartment occurred at the forth feeding time (16.00 after feeding).

Table 4.3 Concentrations of MT in water and suspended solid phase of plastic masculinization pond during 1 day

Time	C_w (ng/L)	C_{sus-s} ($\mu\text{g/kg}$)
9.00 before feeding ^a	2.5 ± 0.0	0.27 ± 0.04
9.00 after feeding ^a	5.3 ± 0.0	0.29 ± 0.11
11.00 after feeding ^a	9.4 ± 0.5	0.37 ± 0.07
16.00 after feeding ^a	25.7 ± 2.1	0.39 ± 0.03

^aConcentration calculation and percent recovery in each set were as shown in appendix B

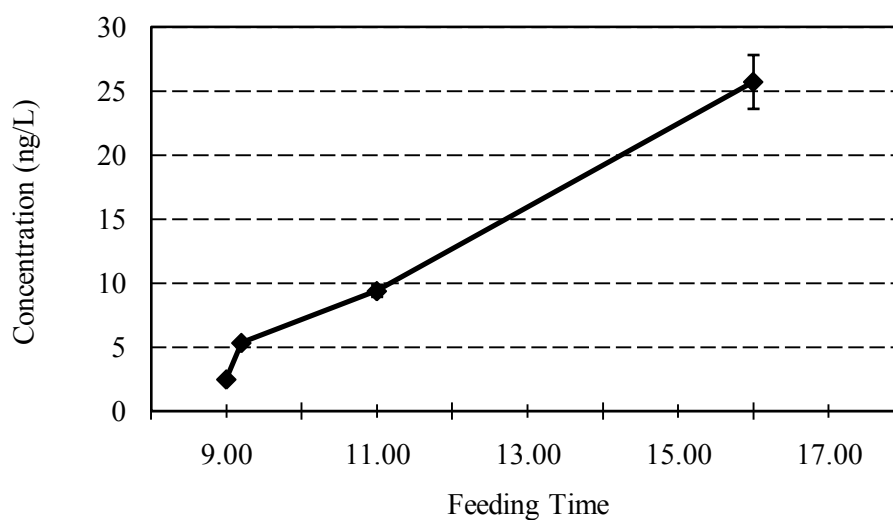

Figure 4.13 Concentration of MT in water compartment of plastic masculinization pond during feeding period from 9.00 to 16.00

MT concentrations in suspended solid phase at 9.00 before feeding, 9.00 after feeding, 11.00 after feeding, and 16.00 after feeding were $0.27 \pm 0.04 \mu\text{g/kg}$, $0.29 \pm 0.11 \mu\text{g/kg}$, $0.37 \pm 0.07 \mu\text{g/kg}$, and $0.39 \pm 0.03 \mu\text{g/kg}$, respectively (Figure 4.14). MT concentrations in suspended solid phase reached the maximum level at 16.00 after feeding.

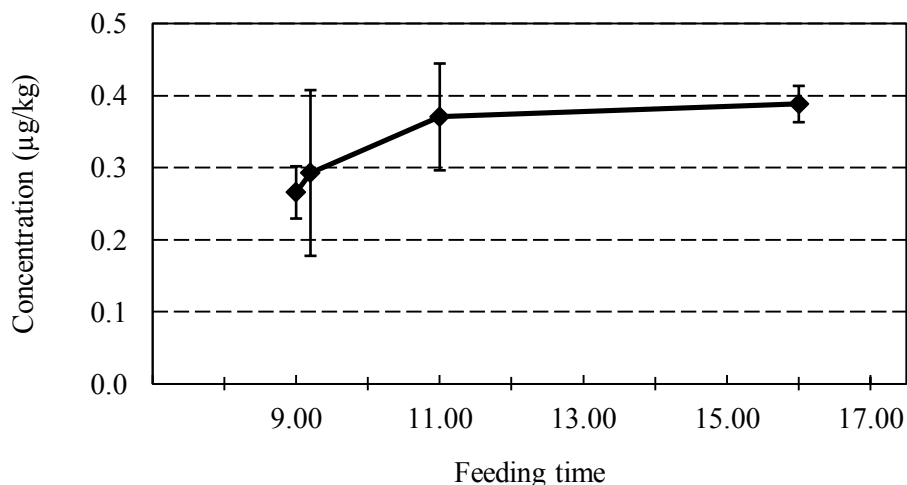

Figure 4.14 Concentrations of MT in suspended solid compartment of plastic masculinization pond during feeding period from 9.00 to 16.00

For the plastic masculinization pond, the observation of MT concentrations in settled solids compartment was neglected as very few settled solids were found in the plastic masculinization pond.

Concrete masculinization pond

Water containing suspended solids and settled solids were collected from the concrete masculinization pond. MT concentrations separately found in water and suspended solid phase after filtration through a glass microfiber filter GF/F 0.7 µm as described in section 3.4.2. MT concentrations in each compartment were as shown in Table 4.4. The concentrations in water compartment at 9.00 before feeding, 9.00 after feeding, 11.00 after feeding, and 16.00 after feeding were 26.78 ± 3.657 ng/L, 33.47 ± 1.533 ng/L, 35.63 ± 0.797 ng/L, and 39.13 ± 1.714 ng/L, respectively (Figure 4.15). MT concentrations in the water compartment increased with the feeding times. The maximum MT concentrations in water compartment occurred at 16.00 after feeding.

Table 4.4 Concentrations of MT in water, suspended solid, and settled solid phase of concrete masculinization pond during 1 day

Time	C_w (ng/L)	C_{sus-s} (µg/kg)	C_{set-s} (µg/kg)
9.00 before feeding ^a	26.8 ± 3.7	0.20 ± 0.03	0.013 ± 0.007
9.00 after feeding ^a	33.5 ± 1.5	0.21 ± 0.05	0.016 ± 0.002
11.00 after feeding ^a	35.6 ± 0.8	0.25 ± 0.03	0.016 ± 0.001
16.00 after feeding ^a	39.1 ± 1.7	0.21 ± 0.03	0.012 ± 0.008

^aConcentration calculation and percent recovery in each set were shown in appendix B

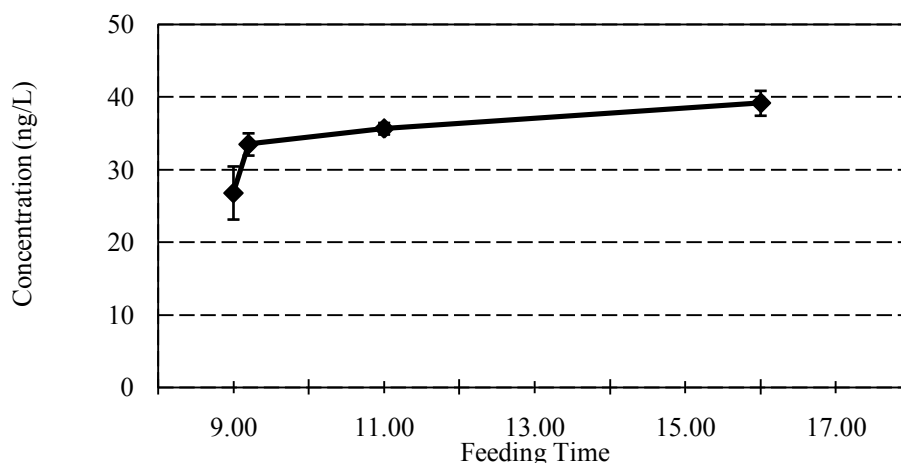

Figure 4.15 Concentrations of MT in water compartment of concrete masculinization pond during feeding period from 9.00 to 16.00

MT concentrations in suspended solid compartment at 9.00 before feeding, 9.00 after feeding, 11.00 after feeding, and 16.00 after feeding were $0.20 \pm 0.03 \mu\text{g/kg}$, $0.21 \pm 0.05 \mu\text{g/kg}$, $0.25 \pm 0.03 \mu\text{g/kg}$, and $0.21 \pm 0.03 \mu\text{g/kg}$, respectively (Figure 4.16). MT concentration in suspended solid compartment was at the maximum level at 16.00 after feeding were $0.01 \pm 0.007 \mu\text{g/kg}$, $0.02 \pm 0.002 \mu\text{g/kg}$, $0.02 \pm 0.001 \mu\text{g/kg}$, and $0.01 \pm 0.008 \mu\text{g/kg}$, respectively (Figure 4.16). MT concentration in settled solids compartment reached to the maximum level at 11.00 and then reduced to nearly the initial concentration at 16.00.

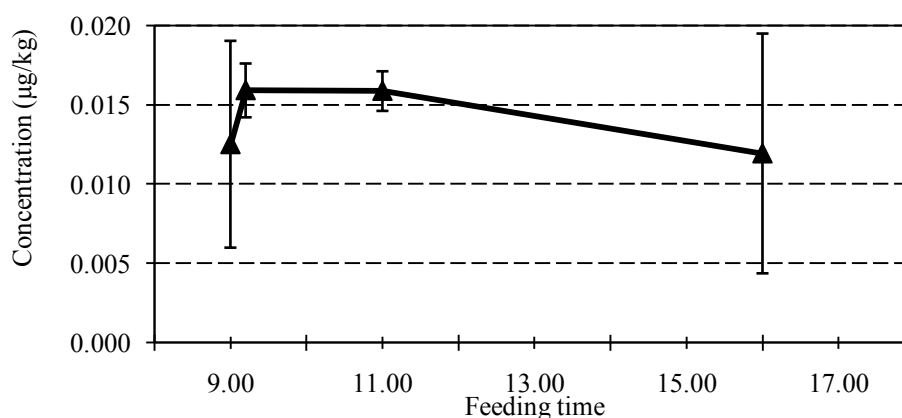

Figure 4.16 Concentrations of MT in settled solid compartment of concrete masculinization pond during feeding period from 9.00 to 16.00

The maximum concentrations of water compartment in the plastic and concrete masculinization ponds occurred at 16.00 after feeding. MT concentrations increased due to

the accumulation of MT that dissolved in water during each feeding time. Solubility of MT is about 3.39 mg/L so it is possible that MT from feeding immediately solute in water compartment. For suspended solid compartment, the maximum concentration for plastic masculinization pond also took place at 16.00 after feeding. MT concentration in suspended solid increased because of the feed that has not been eaten or metabolized spreading throughout the plastic pond. For suspended solid compartment in the concrete masculinization pond, the maximum MT concentration level happened at 11.00 after feeding then the MT concentration decreased slightly. The concentrations of suspended solid in the plastic pond and in the concrete pond were different owing to the difference in operation of these two types of ponds for example, different numbers of fry which were raised in the pond and/or taking sample on the different operation day. For settle solid compartment in the concrete pond, the maximum concentration was found at 11.00 after feeding. Then, MT concentration reduced slightly (almost constant).

4.2.2 30- Day monitoring

Nile tilapia fry was induced to exhibit male sex by feeding the feed mixed with MT (60 mg MT per kg feed) for 21 days and the fry was then raised with the feed without MT until day 30 before moved to the earthen growth pond. Every day, clean water was supplied into the masculinization pond at the flow rate of approximately 2000 L/d to control water temperature in the masculinization pond. This caused the overflow water with the corresponding flow rate released from the masculinization pond to the concrete ditch connected to the earthen channel. After MT was applied into the masculinization pond, it appeared in three compartments comprising of water phase, suspended solids phase, and settled solids. MT mass flow is illustrated according to equation 3.

$$C_{\text{feed}} M_{\text{feed}} = (C_w Q_{\text{out}} + C_{\text{sus-s}} M_{\text{sus-s}} Q_{\text{out}}) + (C_w V_w + C_{\text{sus-s}} M_{\text{sus-s}} V_w + C_{\text{set-s}} M_{\text{set-s}} V_{\text{set-s}}) + MT_{\text{reaction}}$$

Input term was the amount of MT fed together with the feed into the masculinization pond. An output term was the amount of MT in the overflow water released to the concrete ditch. MT in water was found in two phases: water phases and suspended solids phase. The in pond term was MT remaining in the pond. It existed in three compartments: water, suspended solids and settled solids. In this study, we do not account for the in reaction term which include uptake by the fry, excrete by the fry, biotic degradation, abiotic degradation, and etc.

Amount of MT in feed

The amount of MT in feed was calculated from the concentration of MT in the feed (C_{feed}) and the amount of feed (M_{feed}) supplied. In the masculinization process, C_{feed} was set constant to be 60 mg/kg of feed for the whole period of masculinization of 21 days. Daily amount of feed varied depending on the weight of the fry and duration of the process. During the first week, Nile tilapia fry was fed with the feed at the amount 20 % of the fry weight. The amount of feed was reduced to 15 % and 10 % of the fry weight for the second and third weeks, respectively (Phelps and Popma, 2000). The amount of feed and mass of MT in each day were calculated as shown in Table. 4.5 and 4.6.

Table 4.5 The amount of feed and MT in each day in concrete masculinization pond during 21 days of operation

Day	M_{10000 fry} (g)	% feed	M_{feed for 10000 fry} (kg/d)	C_{feed} (mg/kg)	Mass of MT (mg/d)
1	270.0	20	0.054	60	3.24
2	300.0	20	0.060	60	3.60
3	310.0	20	0.062	60	3.72
4	330.0	20	0.066	60	3.96
5	360.0	20	0.072	60	4.32
6	390.0	20	0.078	60	4.68
7	420.0	20	0.084	60	5.04
8	450.0	15	0.068	60	4.05
9	500.0	15	0.075	60	4.50
10	580.0	15	0.087	60	5.22
11	670.0	15	0.101	60	6.03
12	770.0	15	0.116	60	6.93
13	880.0	15	0.132	60	7.92
14	970.0	15	0.146	60	8.73
15	1030.0	10	0.103	60	6.18
16	1580.0	10	0.158	60	9.48
17	1720.0	10	0.172	60	10.32
18	1860.0	10	0.186	60	11.16
19	1980.0	10	0.198	60	11.88
20	2100.0	10	0.210	60	12.6
21	2500.0	10	0.250	60	15.0

Table 4.6 The amount of feed and MT in each day in concrete masculinization pond during day 22 to day 30 of operation

Day	M _{10000 fry} (g)	% feed	M _{feed for 10000 fry} (kg/d)	C _{feed} (mg/kg)	Mass of MT (mg/d)
22	2780.0	10	0.278	0	0
23	3020.0	10	0.302	0	0
24	3400.0	10	0.340	0	0
25	3720.0	10	0.372	0	0
26	4120.0	10	0.412	0	0
27	4470.0	10	0.447	0	0
28	4900.0	10	0.490	0	0
29	5180.0	10	0.518	0	0
30	5390.0	10	0.539	0	0

Total amount of MT in the feed was calculated by summation of the daily mass of MT supplied with the feed. The total amount of MT from was 148.56 mg.

Amount of MT in overflow water

During Nile tilapia fry masculinization process, water containing suspended solids overflow into the concrete ditch. The amounts of MT in the water phase of the overflow can be calculated from the concentrations of MT in the water phase (C_w) and the overflow flow rate (Q_{out}). The amounts of MT in the suspended solid phase of the overflow can be computed from the concentrations of MT in suspended solids phase (C_{sus-s}), concentrations of suspended solids in overflow water (M_{sus-s}), and the overflow flow rate (Q_{out}). C_w , C_{sus-s} and M_{sus-s} (See appendix B, Table B-1) were monitored by collecting the water containing suspended solids and determined for MT concentrations on each compartment (water and suspended solids). The overflow flow rate was estimated by measuring the volume of the overflow water for 5 hours on the days of sampling which was equal to 2174 L/d.

Table 4.7 shows concentrations of MT in water phase (ng/L) and suspended solid phase ($\mu\text{g}/\text{kg}$) on day 1, 7, 11, 16, 21, and 30. The concentrations of MT in suspended solid phase ($\mu\text{g}/\text{kg}$) were converted to the amounts in one unit volume of water (ng/L) and the overall MT in overflow water was the combination of MT in the water phase and suspended solid phase. Percents of MT in the water phase and suspended solid phase of the overflow

water were estimated. Mass of MT for on the non sampling days was computed by using the values of the closest days that samples were collected.

Table 4.7 Concentrations of MT in each compartment of concrete masculinization pond during 30 days

Day	C _w (ng/L)	C _{sus-s} (µg/kg)	C _{set-s} (µg/kg)
1 ^a	4.6 ± 0.5	0.05 ± 0.01	-
7 ^a	39.1 ± 1.7	0.21 ± 0.03	0.01 ± 0.01
11 ^a	0.2 ± 0.0	0.39 ± 0.07	0.02 ± 0.00
16 ^b	0.3 ± 0.0	1.20 ± 0.35	0.33 ± 0.08
21 ^b	1.0 ± 0.1	1.11 ± 0.18	0.67 ± 0.02
30 ^b	0.4 ± 0.0	0.60 ± 0.12	0.20 ± 0.04

^{a,b}Concentration calculation and percent recovery in each set were as shown in appendix B

The overall concentrations of MT (water and suspended solid) in the overflow water during 30 days were between 0.32 and 39.50 ng/L with an average value of 7.620 ng/L. These levels of MT concentrations were found to impact some organisms (Table 2.2). For example, there was the decreasing of 11- ketotestosterone testosterone to the lowest effective level in adult male zebrafish when they exposed MT at 6.4 to 8.5 ng/L. However, when the overflow water is released into receiving water body, the concentrations of MT can be reduced by effect of dilution.

Table 4.8 Daily mass of MT and equivalent concentration of MT in the overflow water during 30 day

Day	Mass MT discharged			Equivalent concentration		
	Water (µg/d)	Sus-s (µg/d)	Total (µg/d)	Water (ng/L/d)	Sus-s (ng/L/d)	Total (ng/L/d)
1*	10.002	0.024	10.026	4.6	0.0	4.7
2	10.002	0.024	10.026	4.6	0.0	4.7
3	10.002	0.024	10.026	4.6	0.0	4.7
4	85.019	0.150	85.169	39.4	0.1	39.5
5	85.019	0.150	85.169	39.4	0.1	39.5
6	85.019	0.150	85.169	39.4	0.1	39.5
7*	85.019	0.150	85.169	39.4	0.1	39.5

Table 4.8 Daily mass of MT and equivalent concentration of MT in the overflow water during 30 day (*continued*)

Day	Mass MT discharged			Equivalent concentration		
	Water ($\mu\text{g/d}$)	Sus-s ($\mu\text{g/d}$)	Total ($\mu\text{g/d}$)	Water (ng/L/d)	Sus-s (ng/L/d)	Total MT per vol. (ng/L/d)
8	85.019	0.150	85.169	39.4	0.1	39.5
9	0.435	0.258	0.693	0.2	0.1	0.3
10	0.435	0.258	0.693	0.2	0.1	0.3
11*	0.435	0.258	0.693	0.2	0.1	0.3
12	0.435	0.258	0.693	0.2	0.1	0.3
13	0.435	0.258	0.693	0.2	0.1	0.3
14	0.652	0.889	1.541	0.3	0.4	0.7
15	0.652	0.889	1.541	0.3	0.4	0.7
16*	0.652	0.889	1.541	0.3	0.4	0.7
17	0.652	0.889	1.541	0.3	0.4	0.7
18	0.652	0.889	1.541	0.3	0.4	0.7
19	2.174	0.799	2.973	1.0	0.4	1.4
20	2.174	0.799	2.973	1.0	0.4	1.4
21*	2.174	0.799	2.973	1.0	0.4	1.4
22	2.174	0.799	2.973	1.0	0.4	1.4
23	2.174	0.799	2.973	1.0	0.4	1.4
24	2.174	0.799	2.973	1.0	0.4	1.4
25	0.870	0.450	1.319	0.4	0.2	0.6
26	0.870	0.450	1.319	0.4	0.2	0.6
27	0.870	0.450	1.319	0.4	0.2	0.6
28	0.870	0.450	1.319	0.4	0.2	0.6
29	0.870	0.450	1.319	0.4	0.2	0.6
30*	0.870	0.450	1.319	0.4	0.2	0.6
Total	478.803	14.045	492.848			

*Day of sample collection

The percents of MT in the water phase and suspended solid phase of the overflow water during day 1 to day 30 were illustrated in figure 4.17. The average percent of MT in the water phase was $71.94 \pm 19.69\%$ and in the suspended solid phase was $28.06 \pm 19.70\%$. The results suggested that MT was more in the water phase than in the suspended solid phase. However, the ratio of MT in both phases changed along the operation period. MT shifted more from water phase to suspended solid phase from the beginning toward the end of the period.

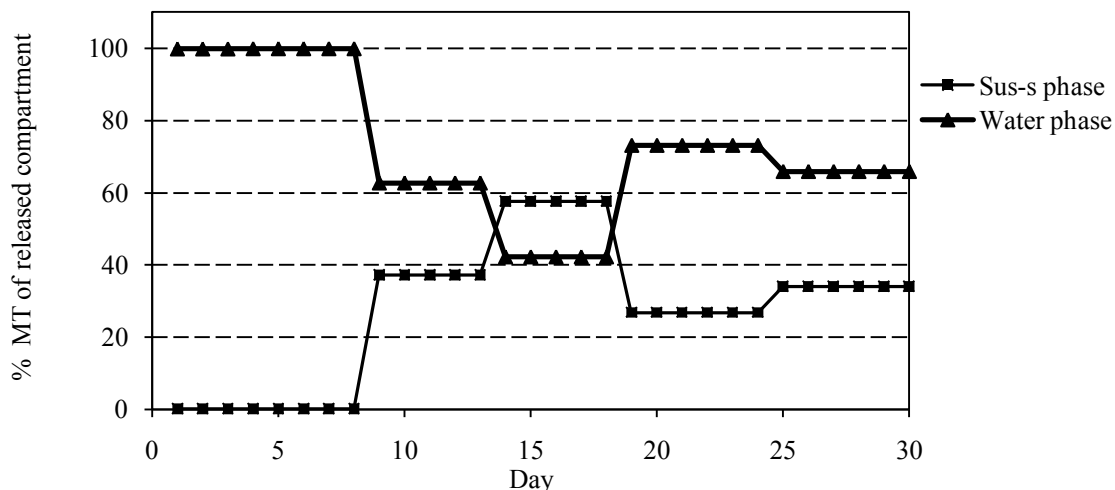

Figure 4.17 Percents of MT in water phase and suspended solid phase in concrete masculinization pond

Amount of MT remaining at the end of operation (day 30)

On day 30, the masculinization pond was cleaned and the remaining MT in water containing suspended solids and settled solids was released into the concrete ditch. The amount of MT remaining in the water phase was calculated from the concentration of MT in the water (C_w) and the volume of the water (V_w). The amount of MT in the suspended solid phase was computed from the concentration of MT in suspended solids ($C_{\text{sus-s}}$), concentration of suspended solids ($M_{\text{sus-s}}$), and volume of water (V_w). The amount of MT in the settled solids was calculated from the concentration of MT in the settled solids (C_{set}), concentration of settled solids (M_{set}), and the volume of settled solids (V_{set}). Table 4.9 shows Mass, percent and equivalent concentrations of MT. The equivalent concentrations of MT was calculated by assuming that all compartments were completely mixed to observe the potential effect of total MT in the pond when released into the environment by comparing to the level found to impact living organisms. The value was calculated by dividing the total mass in all compartments with the volume of the pond water plus solids. The results suggested that the level of 0.59 ng/L was found to below all levels observed to affect living organisms (Table 2.2). Figure 4.18 shows percents of MT in each compartment in the pond on day 30 following. Percents of MT which remaining in water phase, suspended solid phase, and settled solid phase were 64.73 %, 45.26 %, and 1.79 %, respectively. From this result, the majority of MT was found in the water phase. Therefore, the released water should be taken into accounted as they comprised almost all MT remaining in the pond.

Table 4.9 Mass, percent and equivalent concentrations of MT in the pond on day 30

Source of MT	Phase	Parameter	Value	Unit
Mass of MT in pond	Water phase	C_w	0.4	ng/L
		V_w	2156	L
		Mass	0.86	μg
		<hr/>		
	Sus-s phase	$C_{\text{sus-s}}$	0.603	$\mu\text{g}/\text{kg}$
		$M_{\text{sus-s}}$	343	μg
		V_w	2156	L
		Mass	0.45	μg
	Set-s phase	$C_{\text{set-s}}$	0.199	$\mu\text{g}/\text{kg}$
		$M_{\text{set-s}}$	1430	μg
		$V_{\text{set-s}}$	84	L
		Mass	0.02	μg
		Total mass	1.332	μg
<hr/>				
Percent of MT in pond	Water phase		64.73	%
	Sus-s phase		33.47	%
	Set-s phase		1.79	%
<hr/>				
Equivalent concentration of MT	V_{pond}		2240	L
	Water phase		0.39	ng/L
	Sus-s phase		0.2	ng/L
	Set-s		0.01	ng/L
	Total		0.59	ng/L

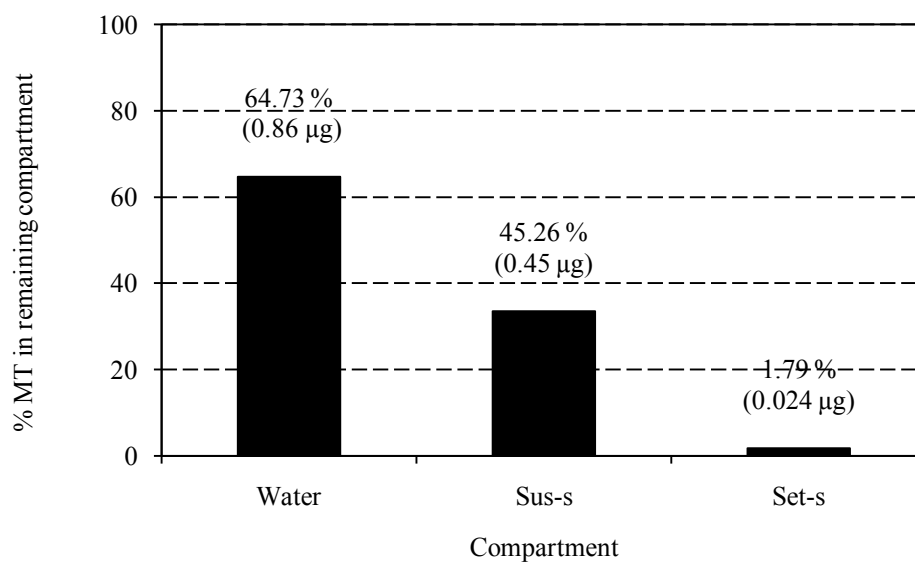
**Figure 4.18** Percents and mass (microgram) of MT in each compartment in the pond on day 30

Overall MT released from masculinization pond of Nile tilapia fry

Table 4.10 Mass and percent of MT released into the environment

Phase	Overflow water		Remaining in the pond on day 30		Total	
	mass	%	mass	%	Mass	%
	μg		μg		μg	
Water	478.80	96.89	0.86	0.17	479.67	97.06
Sus-s	14.05	2.84	0.45	0.09	14.49	2.93
Set-s	-	-	0.02	0.00	0.02	0.005
Total	492.85	99.73	1.33	0.27	494.18	100.00

Table 4.10 shows mass and percent of MT released into the environment during 30 day of operation. For the overflow, mass of MT (492.85 μg , 99.73 %) in the water and suspended solid phases were 478.80 μg (96.89 %), 14.05 μg (2.84 %), respectively. For MT remaining in the pond on day 30, mass of MT (1.33 μg , 0.27 %) in the water, suspended solid and settled solid phases were 0.86 μg (0.17 %), 0.45 (0.09 %), μg , 0.02 μg (0.005 %) respectively. The overall mass of MT (494.18 μg , overflow + remaining in the pond on day 30) found water, suspended solid, and settled solid phases were 479.67 μg (97.06 %), 14.49 (2.93 %), μg , 0.02 μg (<0.005 %) respectively. The majority of MT was released through the overflow water. Therefore, priority should be given to the overflow water to reduce risk of MT released to the environment.

Table 4.11 Mass and percent of MT released into the environment compared to the feed input

Feed	Phase	Overflow water		Remaining in pond on day 30		Total	
		mass	%	mass	% total	Mass	%
(mg)		(μg)		(μg)			
148.56	Water	478.80	0.32	0.86	0.0006	479.67	0.323
	Sus-s	14.05	0.01	0.45	0.0003	14.49	0.010
	Set-s	-	-	0.02	0.0000	0.02	0.000
	Total	492.85	0.33	1.33	0.0009	494.18	0.333
	MT loss					148.07	99.67

Table 4.11 shows mass and percent of MT released into the environment compared to the feed input (148.85 mg). 0.33 % (492.85 μg) of MT was released with the overflow water along 30 days of operation. They were 0.32% (478.80 μg) and 0.01 % (14.05 μg) in the water phase and suspended solid phase, respectively. For MT remaining in the pond on day 30, the

percent of total MT can be accounted as 0.0009 % (1.33 μg) of the total MT supplied to the pond which was in the water phase, suspended solid phase, and settled solid phase of 0.0006 %, 0.0003 %, and < 0.00001 % (0.86 μg , 0.45 μg , and 0.02 μg), respectively. In overall (overflow water + MT remaining in the pond on day 30), 0.333% (494.18 μg) of MT supplied to the pond was released into the environment. Total MT released to the environment was very low compared to percent feed input. MT loss which is accounted in the reaction term (Equation 3.1) may include uptake by the fry, excrete by the fry, biotic degradation, abiotic degradation, and etc which not account for the in reaction term in this study. There was the study about the branchial excretion of MT in rainbow trout. The result reported that MT was reduced partially by the gill. Moreover, branchial reduction was the majority route of excretion which contained 68 % of the excreted radioactivity (Cravedi *et al*, 1993). It is possible that the MT metabolites still contain androgenic activity. The study on MT biotransformation under different electron acceptor showed that MT can be degraded under aerobic, sulfate reducing, and methanogenic conditions. However, in the case of methanogenic condition, androgenic activity still remained (Homklin *et al*, 2010). Therefore, the further study is needed to develop the method to detect androgenic activity under low levels to find out the remaining androgenic activity in the masculinization process of Nile tilapia fry.

4.3 Occurrence of MT in discharge area of concrete ponds

Overflow water from all 20 concrete masculinization ponds flowed through the 20-m-long concrete ditch and released into the earthen canal. Water samples containing suspended solids as well as settled solids samples were taken from three different positions. Two positions were at the inlet (position 1) and outlet (position 2) of the 20-m-long concrete ditch. The third position was in the earthen canal at the point receiving discharge from the concrete ditch (position 3). Samples were taken on day 1, 16, and 30 and the methods for analysis MT in each compartment were as described above.

Table 4.12 Concentrations of MT in water and settled solid samples at three different locations on day 1, 16, and 30

Day	Location	Conc. in water			Conc. in set-s	
		Conc. in water phase	Conc. in sus-s phase			Total conc. in water
		(ng/L)	(µg/kg)	(ng/L)		(ng/L)
1 ^c	1	0.26 ± 0.02	0.15 ± 0.02	0.03 ± 0.00	0.29 ± 0.02	0.10 ± 0.00
	2	0.20 ± 0.01	0.07 ± 0.00	0.01 ± 0.00	0.21 ± 0.01	0.06 ± 0.00
	3	0.12 ± 0.02	0.03 ± 0.00	0.01 ± 0.00	0.13 ± 0.02	0.01 ± 0.00
16 ^c	1	0.27 ± 0.01	0.11 ± 0.01	0.02 ± 0.00	0.29 ± 0.01	0.07 ± 0.05
	2	0.20 ± 0.00	0.05 ± 0.02	0.02 ± 0.01	0.22 ± 0.01	0.07 ± 0.05
	3	0.12 ± 0.00	0.03 ± 0.01	0.01 ± 0.00	0.13 ± 0.00	0.12 ± 0.00
30 ^c	1	0.27 ± 0.01	0.13 ± 0.01	0.03 ± 0.00	0.29 ± 0.01	0.10 ± 0.01
	2	0.20 ± 0.03	0.07 ± 0.02	0.01 ± 0.00	0.22 ± 0.03	0.06 ± 0.00
	3	0.13 ± 0.02	0.03 ± 0.01	0.01 ± 0.00	0.14 ± 0.02	0.01 ± 0.00

^cConcentration calculation and percent recovery in each set were as shown in appendix B

Table 4.12 shows concentrations of MT in each compartment. Figure 4.19 and 4.20 report the concentration profiles for water (water phase + sus-s phase) and settled solids. Similar concentrations profiles appeared for all days. In water, the majority of MT was found in waste phase rather than suspended solid phase. The highest concentrations (0.29 ng/L and 0.07-0.10 $\mu\text{g}/\text{kg}$ for water and settled solids, respectively) were found at the inlet of the concrete ditch and the concentrations reduced to 0.21-0.22 ng/L and 0.06-0.07 $\mu\text{g}/\text{kg}$ for water and settled solids, respectively, at the outlet point of the concrete ditch. Dissolved oxygen concentrations in the concrete ditch were >3 mg/L suggesting fully aerobic condition in the concrete ditch. Homklin *et al.* (2010) demonstrated that MT can be rapidly degraded to the compounds with no androgenic activity under aerobic condition. Aerobic bacteria in the concrete ditch may cause the reduction of MT levels along the ditch. The overflow water was released into the earthen pond. MT in the overflow water was diluted with original water in the pond causing the lower levels MT comparing to the outlet of the concrete ditch. The MT concentrations in the water of the pond were in the range of 0.13-0.14 ng/L and it was 0.01 $\mu\text{g}/\text{kg}$ in the pond sediment. This level of MT was found to be below the levels reported to affect living organisms (Table 2.2).

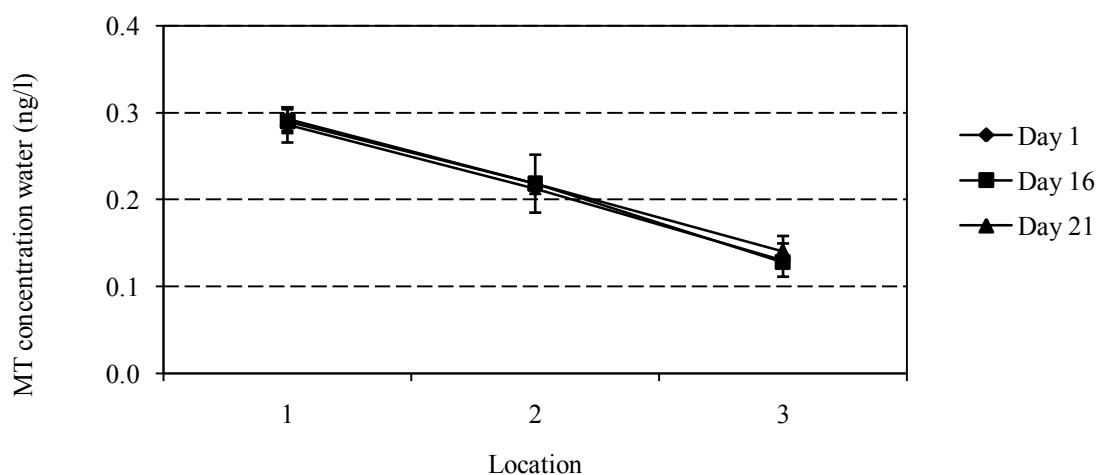

Figure 4.19 Profiles of MT concentrations in water (water phase + sus-s phase)

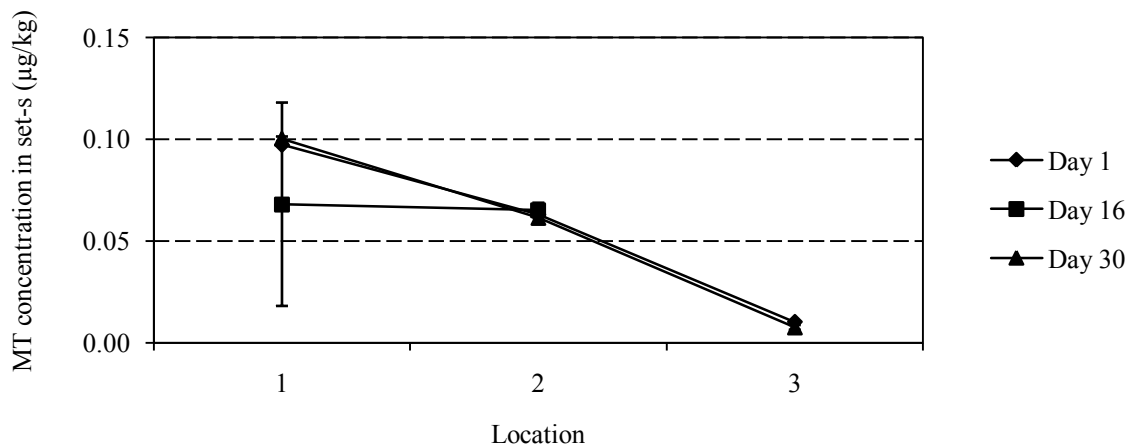

Figure 4.20 Profiles of MT concentrations in settled solid

4.4 Summary of occurrence of MT in masculinization ponds of Nile tilapia fry and discharged area

MT from feed contaminated the receiving environment through two approaches which were the overflow water in each day and the remaining water and suspended solids in the pond on the last day of the operation. Equivalent concentration and mass of MT in each compartment were determined.

4.4.1 Concentration of MT in each compartment of masculinization pond of Nile tilapia during 30 day of the operation

Equivalent concentration of MT in water, suspended solid phase, and settled solid phase is shown in figure 4.21

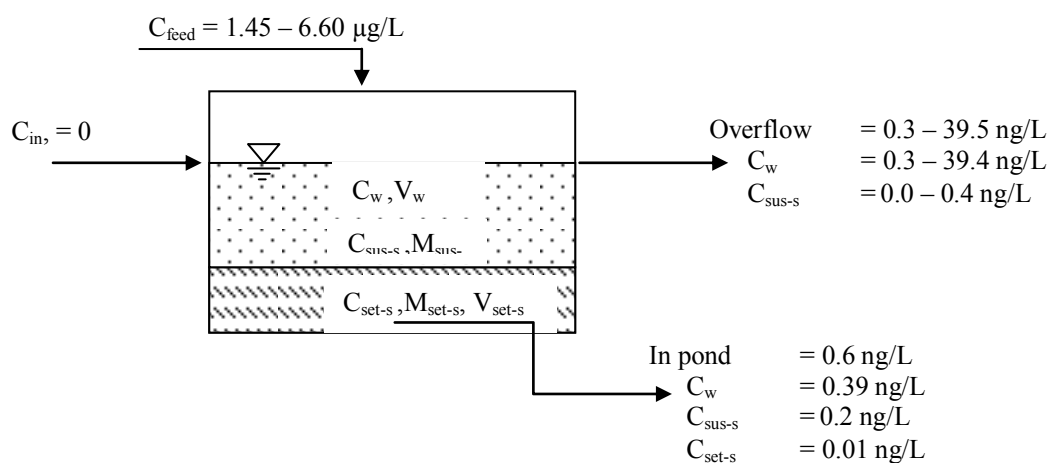

Figure 4.21 Concentrations of MT in each compartment of masculinization pond (2240 L) of Nile tilapia during 30 day of the operation

4.4.2 Percent of MT in each compartment compared to the total input mass of MT

Percent of MT compared to the total input mass of MT in water, suspended solid phase, and settled solid phase is shown in figure 4.22

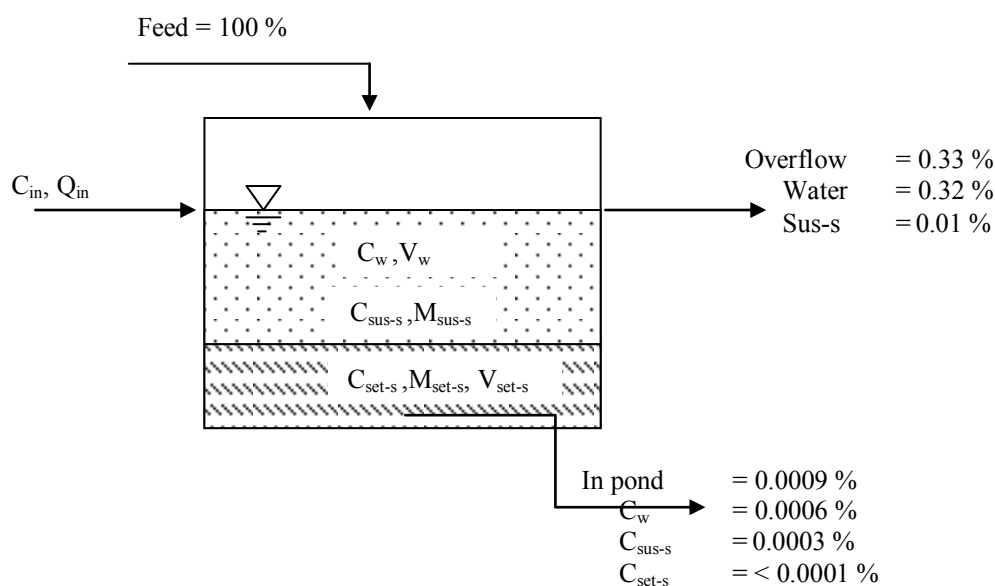

Figure 4.22 Percent of MT in each compartment compared to the total input mass of MT

4.4.3 Mass and percent of MT in each compartment compared to total mass of MT released to environment

Percent of MT compared to the total MT discharged in water, suspended solid phase, and settled solid phase is shown in figure 4.23

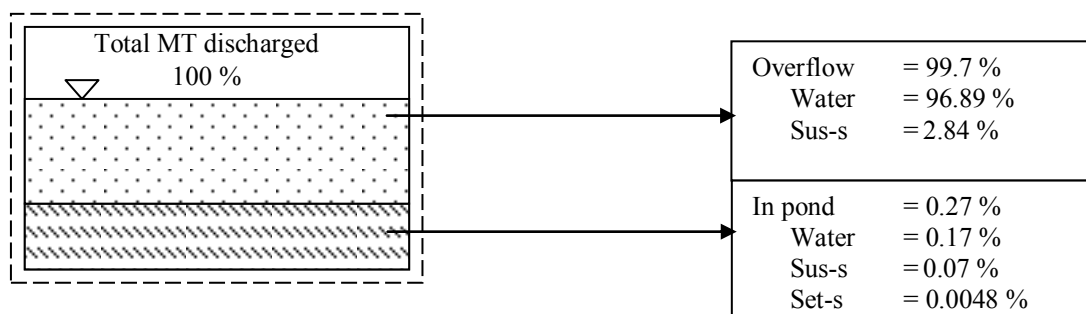

Figure 4.23 Mass and percent of MT in each compartment compared to total mass of MT released to environment

4.4.4 Concentration of MT in each compartment of discharge area during 30 days

Concentration of MT in discharged area in water (water phase and suspended solid phase), and settled solid phase is shown in figure 4.24

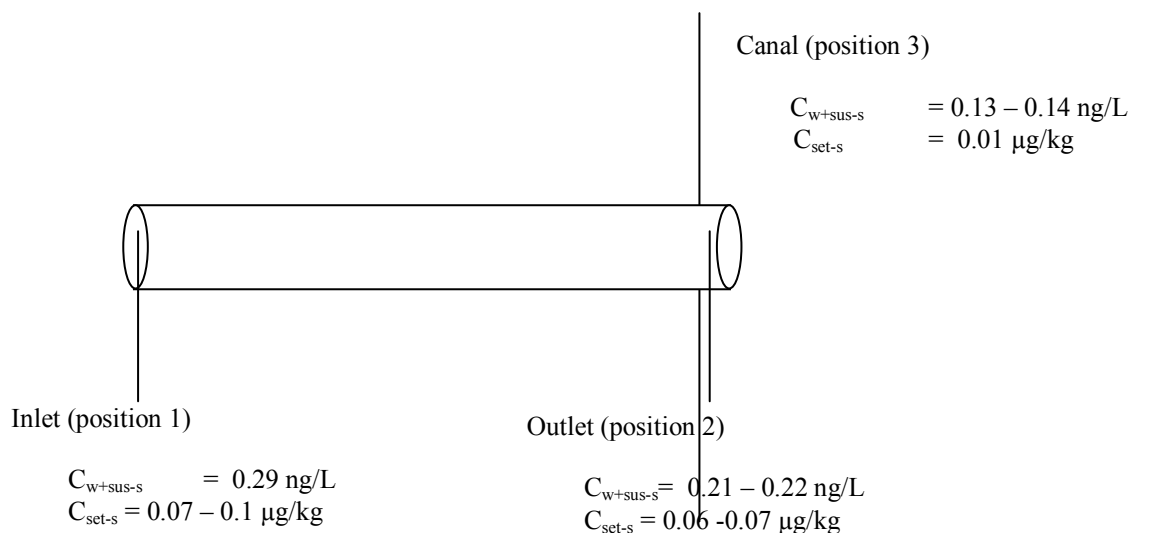

Figure 4.24 Concentration of MT concentrations of MT in each compartment in discharged area during 30 day

CHAPTER V

CONCLUSION AND RECOMMEDATION

5.1 Conclusion

This study aims to observe the occurrence of MT in Nile tilapia fry masculinization ponds and their discharged area.

To monitor MT, MT was extracted from water and sediment samples using SPE and LPE (methanol), respectively. MT concentrations in the elution were determined using UPLC-MS/MS or HPLC. For water samples, MT was spiked into the samples to obtain the final concentrations of 1, 10 and 100 ng/L. The percent recoveries of the extraction method were 72 – 92 %. For sediment samples, MT was spiked to the samples for the final concentrations of 1, 10 and 100 µg/kg. The percent recoveries of the extraction method were 50 – 81 %.

To observe the occurrence of MT in Nile tilapia fry masculinization ponds, the MT concentrations in each compartment including water phase, suspended solids phase and settled solids phase were monitored during the period of 1-day and 30-day bases. The occasionally monitoring during 1-day period was to investigate the change of MT concentrations within a day and to define the time in the day that MT reached the maximum level. The maximum MT concentrations in most compartments occurred at the end of the forth (last) feeding time (16.00). Therefore, for 30-day-monintoring study, samples from each compartment were collected at 16.00.

MT was input into the pond through the feed and was released into the environments by two approaches: 1) with the daily overflow water (water phase and suspended solids phase) and 2) with the water (water phase and suspended solid phase) and settled solid remaining in the pond on the last day of operation (day 30). Total mass and percents of MT appeared in each compartment were estimated using some assumptions.

In the overflow water, MT was found in the concentration range of 0.3 – 39.1 ng/l for the water phase and 0.05 – 1.20 µg/kg for the suspended solid phase. The overall concentration of MT in the overflow water was 0.3 – 39.5 ng/L. For MT remaining in the pond on day 30, the concentrations of MT were 0.4 ng/L for the water phase, 0.60 µg/kg for the suspended solid phase and 0.02 µg/kg for the settled solid phase. After assuming that MT in all compartments of day 30 was mixed completely before discharged, equivalent MT concentration in discharge water was calculated was and found to be 0.6 ng/L. The ranges of

the MT concentrations found in the overflow water were in the ranges reported to affect organisms (6.5 ng/L). However, the levels of MT in the overflow water cannot be directly used to imply the effect to the environment because the overflow water was further discharged into the concrete ditch and when it was released into natural receiving water, MT level can be significantly reduced due to effect of dilution.

Comparing to the total mass of MT supplied with the feed into the pond, 0.33 % (492.85 μg) of MT was released with the overflow water along 30 days of operation. They were 0.32% (478.80 μg) and 0.01 % (14.05 μg) in the water phase and suspended solid phase, respectively. For MT remaining in the pond on day 30, the percent of total MT can be accounted as 0.0009 % (1.33 μg) of the total MT supplied to the pond which was in the water phase, suspended solid phase, and settled solid phase of 0.0006 % (0.86 μg), 0.0003 % (0.45 μg), and < 0.00001 % (0.02 μg), respectively. In overall (overflow water + MT remaining in the pond on day 30), 0.333% (494.18 μg) of MT supplied to the pond was released into the environment.

Comparing to the total MT released into the environment, MT in the overflow water of 492.85 μg can be accounted for 99.73 %. MT in the water phase was 96.89 % (478.80 μg) and was 2.84 % (14.05 μg) in the suspended solid phase. For MT remaining in the pond on day 30, the total mass of MT was 0.27 % (1.33 μg) which were 0.17 % (0.86 μg), 0.09 % (0.45 μg), 0.005 % (0.02 μg) in the water phase, suspended solid phase, and settled solid phase, respectively. Combining all MT released into the environment (overflow water + MT remaining in the pond on day 30), the total mass of MT was 494.18 μg which was distributed 97.06 % (479.67 μg), 2.93 % (14.49 μg), <0.005 % (0.02 μg) in water phase, suspended solids phase, and settled solids phase, respectively. The majority of MT (>99%) was released through the overflow water. Therefore, priority should be given to the overflow water to reduce risk of MT released to the environment. .

To investigate the occurrence of MT in the discharge area, water samples containing suspended solid as well as settled solid samples were taken from three different positions of the concrete ditch and receiving earthen canal in three different occasions (day 1, day 16, and day 30). The highest concentrations of MT (0.29 ng/L and 0.07-0.10 $\mu\text{g}/\text{kg}$ for water (water phase + suspended solid phase) and settled solid, respectively) were found at the inlet of the concrete ditch and the concentrations reduced to 0.21-0.22 ng/L and 0.06-0.07 $\mu\text{g}/\text{kg}$ for water phase + suspended solid phase) and settled solid, respectively, at the outlet point of the concrete ditch. The overflow water was released into the earthen pond. MT in the overflow water was diluted with original water in the pond causing the lower levels MT comparing to

the outlet of the concrete ditch. The MT concentrations in the water of the pond were in the range of 0.13-0.14 ng/L and it was 0.01 µg/kg in the pond sediment. The levels of MT in the receiving water were found to be lower than the levels reported to affect organisms (6.5 ng/L).

5.2 Recommendation for further study

The main limitations of this study were found in two aspects. The first aspect is that this study included only MT in the free form in the measurement. In fact, MT occurring in the ponds can be found both free and conjugated form. A few studies on fate of estrogens in the environments showed that most of estrogens excreted from human and animal bodies occurred in conjugate forms. However, the conjugated forms possess 10000 times lower estrogenic potentials than the free forms and the conjugate estrogens can be converted back to the free form by some microorganisms in sewerage system. Therefore, we recommend further study to clarify fate of MT in the masculinization process of Nile tilapia fry. In this case, all forms of MT should be identified and monitored.

The second aspect is that the metabolites of MT derived after abiotic or biotic degradation of MT were not included in this study. It is possible that the MT metabolites still contain androgenic activity. The study on MT biotransformation under different electron acceptor showed that MT can be degraded under aerobic, sulfate reducing, and methanogenic conditions. However, in the case of methanogenic condition, androgenic activity still remained. Therefore, we recommend further study to develop the method to detect androgenic activity under low levels to find out the remaining androgenic activity in the masculinization process of Nile tilapia fry.

REFERENCES

- Abucay J.S and Mair G.C. Hormonal sex reversal of tilapias: implications of hormone treatment application in closed water systems. Aquaculture Research 28 (1997): 841-845.
- Andersen L., Goto-Kazeto R., Tran M.J. Short-term exposure to low concentrations of the synthetic androgen methyltestosterone affects vitellogenin and steroid levels in adult male zebrafish (*Danio rerio*). Aquatic Toxicology 76 (2006): 343–352.
- Barry P.T., Marwah A. and Marwah P. Stability of 17 α -methyltestosterone in fish feed. Aquaculture 271 (2007): 523–529.
- Beardmore A. J., Mair C.G. and Beardmore A.J. Monosex male production in finfish as exemplified by tilapia: applications, problems, and prospects. Aquaculture 197 (2001): 283–301.
- Bowden J.A., Colosi D.M., Mora-Montero D.C., Garrett T.J., and Yost R.A. Evaluation of derivatization strategies for the comprehensive analysis of endocrine disrupting compounds using GC/MS. Journal of Chromatographic Science 47 (2009): 44-51.
- Chang H., Wu S., Hu J., Asami M. and Kunikane S. Trace analysis of androgens and progestogens in environmental waters by ultra-performance liquid chromatography–electrospray tandem mass spectrometry. Journal of Chromatography A 1195 (2008): 44–51.
- Daeseleire E., De Guesquiere A. and Van Peteghem, C. Combined high-performance liquid chromatography and radioimmunoassay for the screening of 19-nortestosterone and methyltestosterone residues in meat samples. Journal of Chromatography - Biomedical Applications 564 (1991) 445-449.
- Defraipont M. and Sorensen P.W. Exposure to the pheromone 17, 20 β - dihydroxy-4-pregnen-3-one enhances the behavioral spawning success, sperm production and sperm motility of male goldfish. Animal Behavior 46 (1993): 245–256.
- Fitzpatrick M.S. and Contreras-Sanchez W.M. Fate of methyltestosterone in the pond environment: detection of MT in soil after treatment with MT food. In K. McElwee, D. Burke, M. Niles, X. Cummings, and H. Egna, (eds),

- Seventeenth Annual Technical Report, Pond Dynamics, Oregon State University, Corvallis, Oregon, U.S.A., 2000, pp.109-112. Oregon, U.S.A., Aquaculture CRSP, 2000.
- Fitzpatrick M.S., Pereira C.B., and Schreck C.B. In vitro steroid secretion during early development of mono-sex rainbow trout: sex differences, onset of pituitary control, and effects of dietary steroid treatment. General and comparative endocrinology 91 (1993): 199–215.
- Francese P. Endocrine sex control strategies for the feminization of teleost fish. Aquaculture 197 (2001): 229-281
- Homklin S., Ong K.S. and Limpiyakorn T. Biotransformation of 17 α -methyltestosterone in sediment under different electron acceptor conditions. Chemosphere 82 (2011): 1401–1407.
- Howell M.W. and Denton E.T. Gonopodial morphogenesis in female mosquitofish, *Gambusia affinis*, masculinized by exposure to degradation products from plant sterols. Environmental Biology of Fishes 24 (1989): 43-51.
- Thorsten Hüffer. Determination of 17 α -methyltestosterone in sediment samples from a Nile tilapia earthen nursery pond. Master's Thesis, Environmental Management, Graduate School Chulalongkorn University, 2010.
- Jansen E.H., Van den Berg R.H., Zomer G., and Stephany R.W. A chemiluminescent immunoassay for 17 α -methyltestosterone. Food Additive Contamination 2 (1985): 47-53.
- Jenkins L.K., Wilson M.E., Angus A.R., Howell M.W., Kirk M., Moore R., Nance M and Brown A. Production of Androgens by Microbial Transformation of Progesterone in Vitro: A Model for Androgen Production in Rivers Receiving Paper Mill Effluent. Environmental Health Perspectives 12 (2004): 1508-1511.
- Kang J.I., Yokota H., Oshima Y., Tsuruda Y., Shimasaki Y. and Honjo T. The effects of methyltestosterone on the sexual development and reproduction of adult medaka (*Oryzias latipes*). Aquatic Toxicology 87 (2008): 37–46.
- Kavlock J.R. Overview of endocrine disruptor research activity in the United States. Chemosphere 39(1999): 1227-1236.
- Kolodziej P.E. Gray L.T., Sedlek L.D. Quantification of steroid hormones with pheromonal properties in municipal wastewater effluent. Environmental Toxicology and Chemistry. 22 (2003): 2622–2629.

- Kolodziej P.E., Gray L.T., Sedlek L.D. Rangeland grazing as a source of steroid hormones to surface waters. Environmental Science and Technology 41 (2007): 3514-3520.
- Korsgaard B. Effects of the model androgen methyltestosterone on vitellogenin in male and female eelpout *Zoarces viviparus*. Marine Environmental Research 62 (2006): S205–S210.
- Kuwaye T.T., Okimoto D.K., Shimoda S.S., Howerton R.D., Lin H.R., Pang P.K.T., and Grau E.G. Effect of 17 α - methyltestosterone on the growth of the euryhaline tilapia, *Oreochromis mossambicus*, in fresh water and in seawater. Aquaculture 113 (1993): 136–152.
- Liu S., Ying G.G., Zhao L.J., Chen F., Yang B., Zhou J.L. and Lai J.H. Trace analysis of 28 steroids in surface water, wastewater and sludge samples by rapid resolution liquid chromatography–electrospray ionization tandem mass spectrometry. Journal of Chromatography A (article in press).
- MacIntosh, D. J., Little, D. C. Nile tilapia *Oreochromis niloticus*. In: Bromage N. R., and Roberts R. J. (eds.) Broodstock management and egg and larval quality. 277-320, Cambridge, MA, USA, Blackwell, 1995
- Nakata S., Hasumi M. and Sato J. Prostate cancer associated with long-term intake of patent medicine containing methyltestosterone: A case report. Acta urologica Japonica 43(1997): 791-793.
- Oehlmann M., Score J.A. and Blow J. The role of Cdc6 in ensuring complete genome licensing and S phase checkpoint activation. The Journal of Cell Biology 165 (2004): 181–190.
- Purdom, C.E., Hardiman, P.A. Bye, V.V., Eno, N.C., Tyler, C.R., Sumpter, J.P. Estrogenic effects of effluents from sewage treatment works. Chemistry and Ecology 8 (1994): 275-285.
- Selzsam B., Grote K., Gericke C., Niemann L., Wittfoht W., and Chahoud I. Effects of methyltestosterone on reproduction in the Japanese quail (*Coturnix coturnix japonica*). Environmental Research 99 (2005): 327-334.
- Soe, K.L., Soe, M., and Gluud, C. Liver pathology associated with the use of anabolicandrogenic steroids. Liver International 12 (1992): 73-91.
- Sumpter, J.P., Johnson, A.C. 10th anniversary perspective: Reflections on endocrine disruption in the aquatic environment: from known knowns to unknown

- unknowns (and many thing in between). Journal of Environmental Monitoring 10 (2008): 1476-1485.
- Van Peteghem, C., Van Look, L and De Guesquiere, A. Chemiluminescence immunoassay for the detection and quantification of methyltestosterone residues in muscle tissue. Journal of Chromatography B 489 (1989): 219-223.
- Vulliet E., Wiest L., Baudot R., and Grenier-Loustalot M.F. Multi-residue analysis of steroids at sub-ng/L levels in surface and ground-waters using liquid chromatography coupled to tandem mass spectrometry. Journal of Chromatography A 1210 (2008): 84-91.
- Yamamoto H., Liljestrand H.M., Shimizu Y. and Morita M. Effects of physicochemical characteristics on the sorption of selected endocrine disruptors by dissolved organic matter surrogates. Environmental Science and Technology 37 (2003): 2646–2657.

Appendices

Appendix A

CONCENTRATION CALCULATION

Water sample

Water sample was extracted using SPE. The 1000 mL of water was loaded through Oasis HLB cartridge. The sample was eluted with ethylacetate and evaporated. The extract was re-dissolved with 1 mL of methanol. This method concentrated the concentration of the sample for 1000 times. The concentration in water phase was calculated as shown below

Where,

$$C_{\text{UPLC}} = \text{Measured concentration from UPLC-MS/MS } (\mu\text{g/L})$$

$$\text{Factor} = \text{Dilution factor} = 0.001$$

$$C_w = \text{Actual concentration in water (ng/L)}$$

$$C_w = C_{\text{UPLC}} \times 0.001 \times 1000 \text{ (ng/L)}$$

In case of suspended solids, 1000 mL of sample was fixed on a glass microfiber paper 0.7 μm . Mass of suspended solids of sample was calculated in unit of milligrams per liter. MT in the fixed sample was extracted using LPE using methanol. The extract was re-dissolved finally with 0.5 mL of methanol. The concentration in suspended solids was calculated as shown below

Where, $C_{\text{UPLC}} = \text{Measured concentration from UPLC-MS/MS } (\mu\text{g/L})$

$$M_{\text{sus-s}} = \text{Mass of suspended solid (mg/L)}$$

$$C_{\text{sus-s}} = \text{Actual concentration in suspended solids } (\mu\text{g/kg})$$

$$C_{\text{sus-s}} = \frac{0.5 \text{ mL} \times M_{\text{sus-s}}}{5 \text{ g} \times 1000} \text{ } (\mu\text{g/kg})$$

Settled solids sample was extracted using LPE. Five grams of dried, grinded, and sieved settled solids was extracted using methanol. In the final step, the supernatant of the extract was dried and re-dissolved with 0.5 mL of methanol. This method concentrated the concentration of sample for 10 times. The concentration in settled solids was calculated as shown below

Where,

C_{UPLC} = Measured concentration from UPLC-MS/MS ($\mu\text{g/L}$)

Factor = Dilution factor = 0.1

C_w = Actual concentration in water ($\mu\text{g/L}$)

C_w = $C_{\text{UPLC}} \times 0.1$ ($\mu\text{g/L}$)

Table A-1 Concentration and percent recovery of MT in spiked water sample

Sample	Spiked conc. (ng/L)	Replicate	C _{UPLC} (µg/L)	Factor	C _w (ng/L)	Blank conc. (ng/L)	% recovery	Avg. C _w (ng/L)	Avg. % recovery
DI water	10	1	9.3	0.001	9.3	0	92.76	8.0 ± 1.1	80.16 ± 11.03
		2	7.5	0.001	7.5	0	75.46		
		3	7.2	0.001	7.2	0	72.25		
	100	1	79.0	0.001	79.0	0	79.04	82.3 ± 2.9	82.31 ± 2.95
		2	83.1	0.001	83.1	0	83.12		
		3	84.8	0.001	84.8	0	84.77		
Pond water	10	1	8.1	0.001	8.1	0	80.89	8.0 ± 0.1	80.19 ± 0.96
		2	8.1	0.001	8.1	0	80.59		
		3	7.9	0.001	7.9	0	79.09		
	100	1	85.2	0.001	85.2	0	85.22	84.4 ± 1.1	84.37 ± 0.11
		2	83.1	0.001	83.1	0	83.11		
		3	84.8	0.001	84.8	0	84.77		

Table A-2 Concentration and percent recovery of MT in spiked sediment sample

Sample	Spiked conc. ($\mu\text{g/L}$)	Replicate	C_{UPLC} ($\mu\text{g/L}$)	Factor	C_{sed} ($\mu\text{g/kg}$)	Blank conc. ($\mu\text{g/kg}$)	% recovery	Avg. C_{sed} ($\mu\text{g/kg}$)	Avg. % recovery
Uncontaminated-MT Sediment	1	1	5.10	0.1	0.51	0	50.98	0.69 ± 0.16	69.02 ± 16.09
		2	8.19	0.1	0.82	0	81.88		
		3	7.42	0.1	0.74	0	74.21		
	10	1	61.09	0.1	6.11	0	61.09	6.06 ± 0.44	60.58 ± 4.36
		2	64.66	0.1	6.47	0	64.66		
		3	55.98	0.1	5.60	0	55.98		
Contaminated-MT Sediment	1	1	6.54	0.1	0.65	0	65.44	0.61 ± 0.04	60.99 ± 4.26
		2	6.06	0.1	0.61	0	60.58		
		3	5.70	0.1	0.57	0	56.95		
	10	1	64.66	0.1	6.47	0	64.66	7.10 ± 0.5	71.00 ± 5.73
		2	75.80	0.1	7.58	0	75.80		
		3	72.54	0.1	7.25	0	72.54		

Table A-3 Concentration of MT in water phase of plastic masculinization pond during 1 day

Time	Replicate	C_{UPLC} ($\mu\text{g/L}$)	Factor	C_w (ng/L)	Avg. C_w (ng/L)
9.00 before feeding	1	2.5	0.001	2.5	2.5 \pm 0.0
	2	2.5	0.001	2.5	
	3	2.5	0.001	2.5	
9.00 after feeding	1	5.3	0.001	5.3	5.3 \pm 0.0
	2	5.3	0.001	5.3	
	3	5.4	0.001	5.4	
11.00 after feeding	1	9.1	0.001	9.1	9.4 \pm 0.5
	2	9.1	0.001	9.1	
	3	9.9	0.001	9.9	
16.00 after feeding	1	23.3	0.001	23.3	25.7 \pm 2.1
	2	27.1	0.001	27.1	
	3	26.7	0.001	26.7	

Table A-4 Concentration of MT in suspended solids phase of plastic masculinization pond during 1 day

Time	Replicate	C_{UPLC} ($\mu\text{g/L}$)	Mass_{sus-s} (g)	Factor	C_{sus-s} ($\mu\text{g/kg}$)	Avg. C_{sus-s} ($\mu\text{g/kg}$)
9.00 before feeding	1	0.10	0.191	2.6	0.26	0.27 \pm 0.04
	2	0.10	0.220	2.3	0.23	
	3	0.13	0.217	2.3	0.30	
9.00 after feeding	1	0.15	0.217	2.3	0.33	0.29 \pm 0.11
	2	0.15	0.195	2.6	0.38	
	3	0.17	0.515	1.0	0.16	
11.00 after feeding	1	0.14	0.251	2.0	0.28	0.37 \pm 0.07
	2	0.18	0.215	2.3	0.41	
	3	0.16	0.193	2.6	0.41	
16.00 after feeding	1	0.16	0.201	2.5	0.39	0.39 \pm 0.03
	2	0.16	0.217	2.3	0.36	
	3	0.16	0.189	2.6	0.41	

Table A-5 Concentration of MT in water phase of concrete masculinization pond during 1 day

Time	Replicate	C _{UPLC} ($\mu\text{g/L}$)	Factor	C _w (ng/L)	Avg. C _w (ng/L)
9.00 before feeding	1	22.8	0.001	22.8	26.8 \pm 3.7
	2	27.5	0.001	27.5	
	3	30.0	0.001	30.0	
9.00 after feeding	1	31.7	0.001	31.7	33.5 \pm 1.5
	2	34.1	0.001	34.1	
	3	34.5	0.001	34.5	
11.00 after feeding	1	35.9	0.001	35.9	35.6 \pm 0.8
	2	34.7	0.001	34.7	
	3	36.2	0.001	36.2	
16.00 after feeding	1	37.4	0.001	37.4	39.1 \pm 1.7
	2	40.8	0.001	40.8	
	3	39.2	0.001	39.2	

Table A-6 Concentration of MT in suspended solids phase of concrete masculinization pond during 1 day

Time	Replicate	C _{UPLC} ($\mu\text{g/L}$)	Mass _{sus-s} (g)	Factor	C _{sus-s} ($\mu\text{g/kg}$)	Avg. C _{sus-s} ($\mu\text{g/kg}$)
9.00 before feeding	1	0.12	0.327	1.5	0.18	0.20 \pm 0.03
	2	0.12	0.285	1.8	0.21	
	3	0.13	0.279	1.8	0.23	
9.00 after feeding	1	0.13	0.342	1.5	0.18	0.21 \pm 0.05
	2	0.13	0.339	1.5	0.19	
	3	0.13	0.235	2.1	0.27	
11.00 after feeding	1	0.13	0.319	1.6	0.21	0.25 \pm 0.03
	2	0.14	0.272	1.8	0.26	
	3	0.14	0.257	1.9	0.27	
16.00 after feeding	1	0.13	0.290	1.7	0.22	0.21 \pm 0.03
	2	0.13	0.282	1.8	0.24	
	3	0.10	0.283	1.8	0.17	

Table A-7 Concentration of MT in settled solids phase of concrete masculinization pond during 1 day

Time	Replicate	C_{UPLC} ($\mu\text{g/L}$)	Factor	C_{set-s} ($\mu\text{g/kg}$)	Avg. C_{set-s} ($\mu\text{g/kg}$)
9.00 ^a before feeding	1	0.054	0.1	0.005	
	2	0.181	0.1	0.018	
	3	0.141	0.1	0.014	0.013 \pm 0.007
9.00 ^a after feeding	1	0.141	0.1	0.014	
	2	0.175	0.1	0.018	
	3	0.161	0.1	0.016	0.016 \pm 0.002
11.00 ^a after feeding	1	0.167	0.1	0.017	
	2	0.144	0.1	0.014	
	3	0.165	0.1	0.017	0.016 \pm 0.001
16.00 ^a after feeding	1	0.165	0.1	0.017	
	2	0.161	0.1	0.016	
	3	0.032	0.1	0.003	0.012 \pm 0.008

Table A-8 Concentration of MT in water phase of concrete masculinization pond during 30 days

Day	Replicate	C_{UPLC} ($\mu\text{g/L}$)	Factor	C_w (ng/L)	Avg. C_w (ng/L)
1 ^a	1	4.0	0.001	4.0	4.6 \pm 0.5
	2	4.9	0.001	4.9	
	3	4.9	0.001	4.9	
7 ^a	1	37.4	0.001	37.4	39.1 \pm 1.7
	2	40.8	0.001	40.8	
	3	39.2	0.001	39.2	
11 ^a	1	0.2	0.001	0.2	0.2 \pm 0.0
	2	0.3	0.001	0.3	
	3	0.3	0.001	0.3	
16 ^b	1	0.4	0.001	0.4	0.3 \pm 0.0
	2	0.3	0.001	0.3	
	3	0.3	0.001	0.3	
21 ^b	1	0.9	0.001	0.9	1.0 \pm 0.1
	2	1.0	0.001	1.0	
	3	1.1	0.001	1.1	
30 ^b	1	0.5	0.001	0.5	0.4 \pm 0.0
	2	0.5	0.001	0.5	
	3	0.4	0.001	0.4	

Table A-9 Concentration of MT in suspended solids phase of concrete masculinization pond during 30 days

Day	Replicate	C_{UPLC} (µg/L)	Mass_{sus-s} (g)	Factor	C_{sus-s} (ug/kg)	Avg. C_{sus-s} (ug/kg)
1 ^a	1	0.04	0.330	1.5	0.06	0.05 ± 0.01
	2	0.02	0.275	1.8	0.05	
	3	0.02	0.278	1.8	0.04	
7 ^a	1	0.13	0.290	1.7	0.22	0.21 ± 0.03
	2	0.13	0.282	1.8	0.24	
	3	0.10	0.283	1.8	0.17	
11 ^a	1	0.23	0.243	2.1	0.47	0.39 ± 0.07
	2	0.21	0.314	1.6	0.33	
	3	0.22	0.296	1.7	0.37	
16 ^b	1	0.66	0.287	1.7	1.15	1.20 ± 0.35
	2	0.86	0.275	1.8	1.57	
	3	0.52	0.296	1.7	0.89	
21 ^b	1	0.75	0.327	1.5	1.15	1.11 ± 0.18
	2	0.68	0.370	1.4	0.91	
	3	0.86	0.338	1.5	1.28	
30 ^b	1	0.45	0.309	1.6	0.73	0.60 ± 0.12
	2	0.33	0.327	1.5	0.50	
	3	0.32	0.276	1.8	0.58	

Table A-10 Concentration of MT in settled solids phase of concrete masculinization pond during 30 days

Day	Replicate	C _{UPLC} (µg/L)	Factor	C _{set-s} (µg/kg)	Avg. C _{set-s} (µg/kg)
1 ^a	1	-	0.1	-	
	2	-	0.1	-	
	3	-	0.1	-	-
7 ^a	1	0.17	0.1	0.02	
	2	0.16	0.1	0.02	
	3	0.03	0.1	0.003	0.01 ± 0.01
11 ^a	1	0.20	0.1	0.02	
	2	0.26	0.1	0.03	
	3	0.28	0.1	0.03	0.02 ± 0.00
16 ^b	1	3.53	0.1	0.35	
	2	2.34	0.1	0.23	
	3	3.92	0.1	0.39	0.33 ± 0.08
21 ^b	1	6.93	0.1	0.69	
	2	6.51	0.1	0.65	
	3	6.79	0.1	0.68	0.67 ± 0.02
30 ^b	1	2.18	0.1	0.22	
	2	1.48	0.1	0.15	
	3	2.31	0.1	0.23	0.20 ± 0.04

Table A-11 Concentration of MT in waster phase of discharged area during 30 days

Day	Location	Replicate	C _{UPLC} (µg/L)	Factor	C _w (ng/L)	Avg. C _w (ng/L)
1 ^c	1	1	0.26	0.001	0.26	0.26 ± 0.02
		2	0.24	0.001	0.24	
		3	0.28	0.001	0.28	
	2	1	0.20	0.001	0.20	0.20 ± 0.01
		2	0.20	0.001	0.20	
		3	0.19	0.001	0.19	
	3	1	0.11	0.001	0.11	0.12 ± 0.02
		2	0.14	0.001	0.14	
		3	0.12	0.001	0.12	
16 ^c	1	1	0.26	0.001	0.26	0.27 ± 0.01
		2	0.28	0.001	0.28	
		3	0.26	0.001	0.26	
	2	1	0.20	0.001	0.20	0.20 ± 0.00
		2	0.20	0.001	0.20	
		3	0.20	0.001	0.20	
	3	1	0.10	0.001	0.12	0.12 ± 0.00
		2	0.12	0.001	0.12	
		3	0.12	0.001	0.12	
30 ^c	1	1	0.28	0.001	0.28	0.27 ± 0.01
		2	0.25	0.001	0.25	
		3	0.27	0.001	0.27	
	2	1	0.19	0.001	0.19	0.20 ± 0.03
		2	0.18	0.001	0.18	
		3	0.24	0.001	0.24	
	3	1	0.13	0.001	0.13	0.13 ± 0.02
		2	0.12	0.001	0.12	
		3	0.15	0.001	0.15	

Table A-12 Concentration of MT in suspended solids phase of discharged area during 30 days

Day	Location	Replicate	C _{UPLC} (µg/L)	Mass _{sus-s} (g)	Factor	C _{sus-s} (µg/kg)	Avg. C _{sus-s} (µg/kg)
1 ^c	1	1	0.05	0.187	2.67	0.13	0.15 ± 0.02
		2	0.06	0.185	2.70	0.16	
		3	0.06	0.163	3.07	0.17	
	2	1	0.03	0.211	2.37	0.07	0.07 ± 0.00
		2	0.03	0.212	2.36	0.07	
		3	0.03	0.183	2.73	0.07	
	3	1	0.01	0.212	2.36	0.03	0.03 ± 0.00
		2	0.01	0.209	2.39	0.03	
		3	0.02	0.214	2.34	0.04	
16 ^c	1	1	0.05	0.209	2.39	0.12	0.11 ± 0.01
		2	0.05	0.22	2.27	0.11	
		3	0.05	0.247	2.02	0.10	
	2	1	0.03	0.203	2.46	0.06	0.05 ± 0.02
		2	0.03	0.229	2.18	0.06	
		3	0.03	0.477	1.05	0.03	
	3	1	0.01	0.21	2.38	0.02	0.03 ± 0.01
		2	0.02	0.207	2.42	0.04	
		3	0.02	0.216	2.31	0.04	
30 ^c	1	1	0.05	0.186	2.69	0.14	0.13 ± 0.01
		2	0.05	0.186	2.69	0.14	
		3	0.05	0.209	2.39	0.12	
	2	1	0.03	0.166	3.01	0.09	0.07 ± 0.02
		2	0.03	0.222	2.25	0.07	
		3	0.02	0.198	2.53	0.06	
	3	1	0.01	0.177	2.82	0.03	0.03 ± 0.02
		2	0.02	0.2	2.50	0.05	
		3	0.01	0.213	2.35	0.03	

Table A-13 Concentration of MT in settled solids phase of discharged area during 30 days

Day	Location	Replicate	C _{UPLC} µg/L	Conc. Factor	C _{set-s} µg/kg	Avg. C _{set-s} µg/kg
1 ^c	1	1	0.99	10	0.10	0.10 ± 0.00
		2	0.97	10	0.10	
		3	0.96	10	0.10	
	2	1	0.64	10	0.06	0.06 ± 0.00
		2	0.66	10	0.07	
		3	0.60	10	0.06	
	3	1	0.12	10	0.01	0.01 ± 0.00
		2	0.09	10	0.01	
		3	0.10	10	0.01	
16 ^c	1	1	0.10	10	0.01	0.07 ± 0.05
		2	0.96	10	0.10	
		3	0.98	10	0.10	
	2	1	0.61	10	0.06	0.07 ± 0.00
		2	0.67	10	0.07	
		3	0.68	10	0.07	
	3	1	1.25	10	0.13	0.12 ± 0.00
		2	1.22	10	0.12	
		3	1.26	10	0.13	
30 ^c	1	1	0.96	10	0.10	0.10 ± 0.01
		2	1.08	10	0.11	
		3	0.98	10	0.10	
	2	1	0.65	10	0.07	0.06 ± 0.00
		2	0.61	10	0.06	
		3	0.58	10	0.06	
	3	1	0.08	10	0.01	0.01 ± 0.00
		2	0.08	10	0.01	
		3	0.07	10	0.01	

Percent recovery in each set of experiment

Water samples

Table A-14 Percent recoveries in each set of water sample

Set	Spiked conc. ng/L	C _{UPLC} µg/L	Factor	C _w ng/L	% Recovery
a	10	7.5	0.001	7.5	75.46
	10	8.1	0.001	8.1	81.00
b	10	8.2	0.001	8.2	81.62
	10	7.2	0.001	7.2	72.22
c	10	8.2	0.001	8.2	81.77
	10	8.0	0.001	8.0	80.17

Table A-15 Percent recoveries in each set of suspended solid samples

Sample	Spiked conc. (µg/kg)	C _{UPLC} µg/L	mass g	Factor	C _{sus-s} (µg/kg)	% Recovery
a	1	1.4	0.235	2.13	0.68	67.83839
	1	1.1	0.293	1.71	0.63	63.03514
b	1	1.0	0.293	1.71	0.61	61.15835
	1	1.1	0.273	1.83	0.57	57.45804
c	1		0.345	1.45		
	1	1.2	0.291	1.72	0.71	70.88275

Table A-16 Percent recoveries in each set of settled solid samples

Sample	Spiked conc. (µg/kg)	C _{UPLC} µg/L	Factor	C _{set-s} (µg/kg)	% Recovery
a	1	5.24	0.1	0.524	52.4
	1	6.81	0.1	0.681	68.1
b	1	8.18	0.1	0.818	81.8
	1	6.37	0.1	0.637	63.7
c	1	7.42	0.1	0.742	74.2
	1	6.53	0.1	0.653	65.3

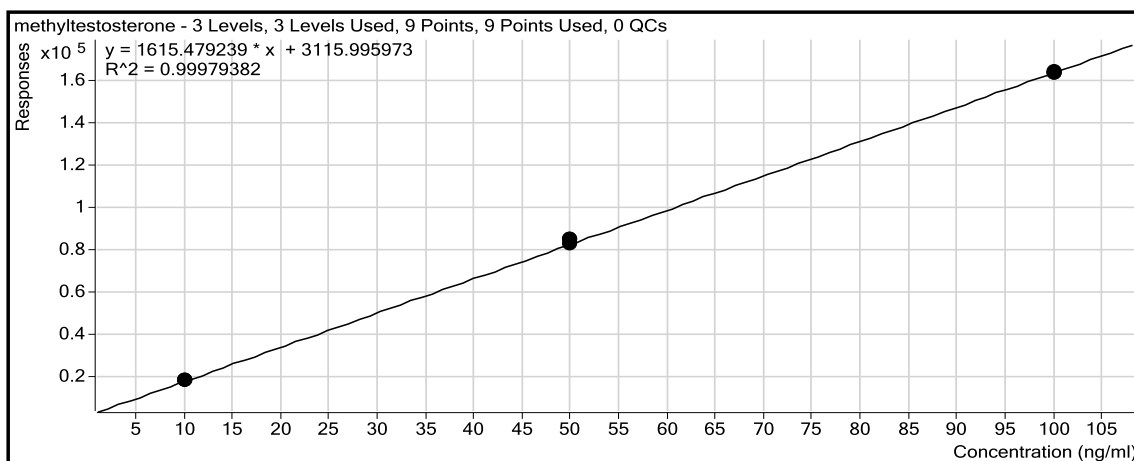

Figure A-1 Calibration curve of MT

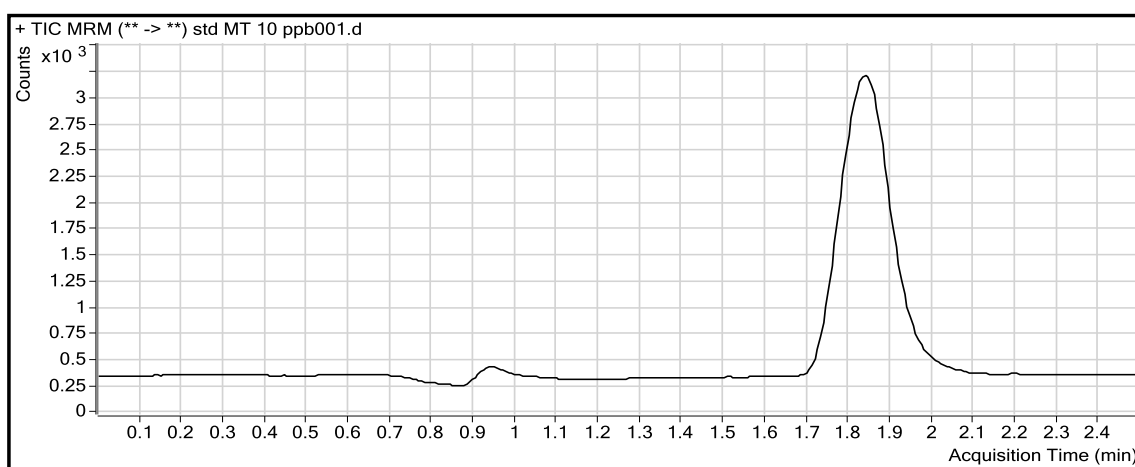

Figure A-2 Chromatogram of standard 10 ppb of MT

Quantitation Results

Compound	RT	Response	Final Conc	ng/ml
methyltestosterone	1.830	18755	9.6808	

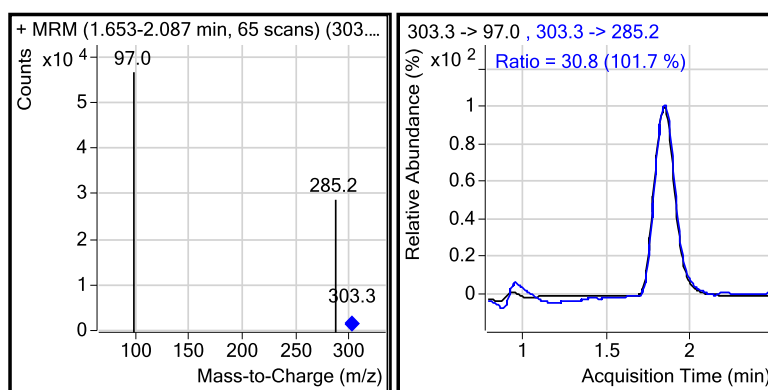

Figure A-3 Mass spectrometry data for standard 10 ppb of MT

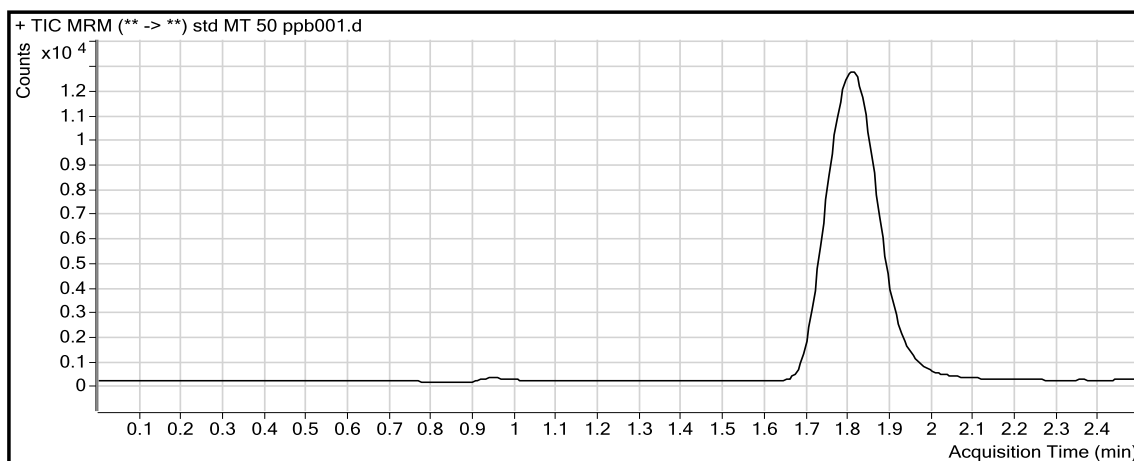

Figure A-4 Chromatogram of standard 50 ppb of MT

Quantitation Results

Compound	RT	Response	Final Conc	
methyltestosterone	1.804	85210	50.8172	ng/ml

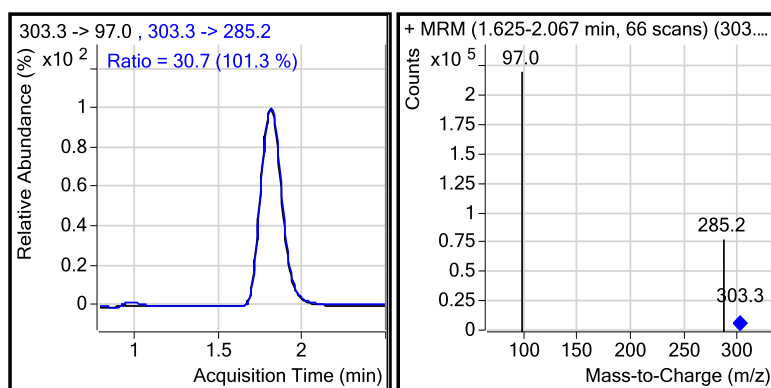

Figure A-5 Mass spectrometry data of standard 50 ppb of MT

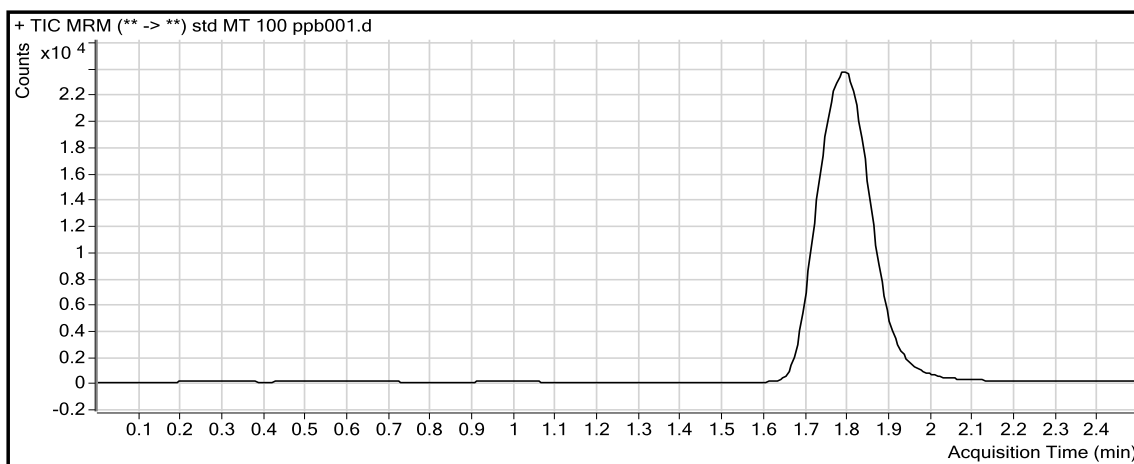

Figure A-6 Chromatogram of standard 100 ppb of MT

Quantitation Results

Compound	RT	Response	Final Conc	
methyltestosterone	1.788	164282	99.7639	ng/ml

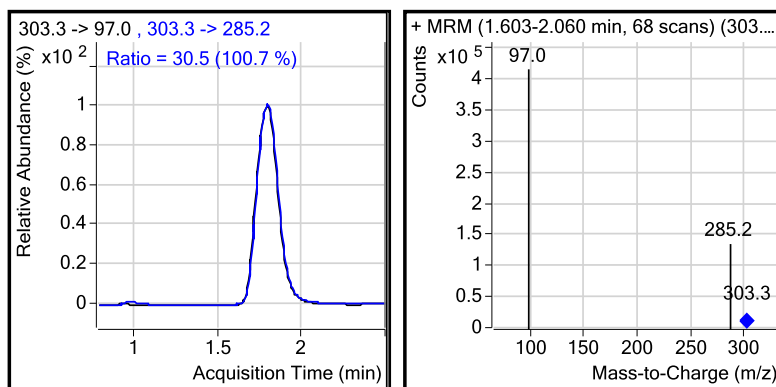

Figure A-7 Mass spectrometry data of standard 100 ppb of MT

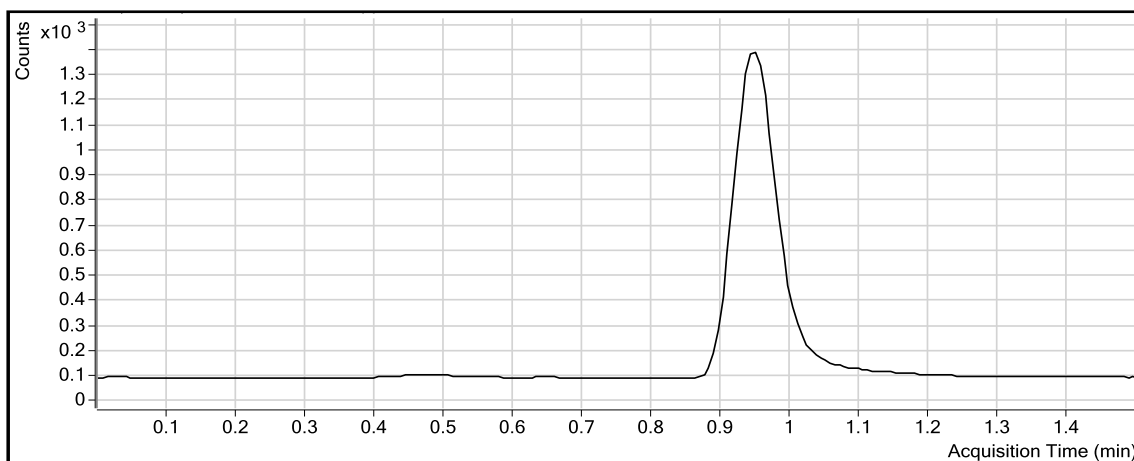

Figure A-8 Chromatogram of spiked water sample set a

Quantitation Results

Compound	RT	Response	Final Conc	
methyltestosterone	0.949	4554	7.5460	µg/L

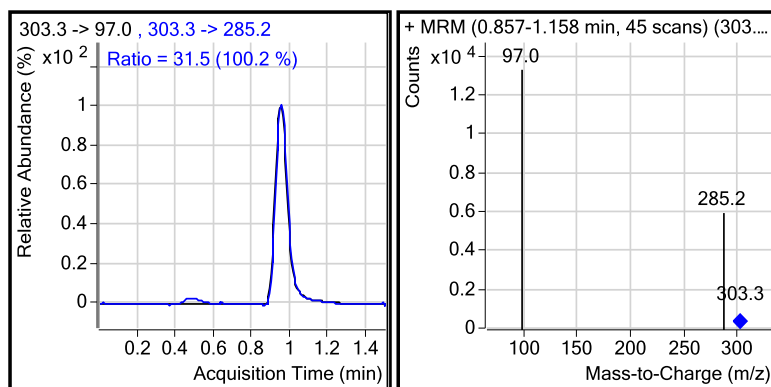

Figure A-9 Mass spectrometry data of spiked water sample set a

Appendix B

Amount of MT in overflow water

The amounts of MT in the water phase of the overflow can be calculated from the concentrations of MT in the water phase and MT in the suspended solid phase as shown in equation B-1

$$MT_{\text{overflow}} = C_w Q_{\text{out}} + C_{\text{sus-s}} M_{\text{sus-s}} Q_{\text{out}} \dots \dots \dots \text{B-1}$$

C_w , $C_{\text{sus-s}}$ and $M_{\text{sus-s}}$ were monitored by collecting the water containing suspended solids. Mass of suspended solids during 30 days of masculinization process was as shown in Table B-1

Table B-1 Mass of suspended solids during 30 day of masculinization process

Day	Replicate	Mass (g)	Vol. (mL)	$M_{\text{sus-s}}$ (mg/L)	Avg. $M_{\text{sus-s}}$ (mg/L)
1	1	0.0021	10	210	230
	2	0.0024	10	240	
	3	0.0024	10	240	
7	1	0.0033	10	330	330
	2	0.0032	10	320	
	3	0.0034	10	340	
11	1	0.0032	10	320	303
	2	0.0029	10	290	
	3	0.003	10	300	
16	1	0.0033	10	330	340
	2	0.0034	10	340	
	3	0.0035	10	350	
21	1	0.0033	10	330	330
	2	0.0035	10	350	
	3	0.0031	10	310	
30	1	0.0034	10	340	343
	2	0.0035	10	350	
	3	0.0034	10	340	

The overflow flow rate was estimated by measuring the volume of the overflow water for 5 hours on the day of sampling which was equal to 2174 L/d. Mass of MT in the overflow water were calculated by assumed the concentration of MT in each phase of day 1-3, day 4-8,

day 9-13, day 14-18, day 19-23, and day 24-30 were equal to the concentration of day 1, 7, 11, 16, 21, and 30, respectively. The daily mass of MT was as shown in Table B-2.

Table B-2 The calculation of mass of MT in the overflow water during 30 day

Day	Overflow						
	Water phase			Sus-s phase			
	C _w ng/L	Q _{out} L/d	Mass µg/d	C _{sus-s} µg/kg	M _{sus-s} mg/L	Q _{out} L/d	Mass µg/d
1*	4.6	2174	10.002	0.047	230	2174	0.024
2	4.6	2174	10.002	0.047	230	2174	0.024
3	4.6	2174	10.002	0.047	230	2174	0.024
4	39.1	2174	85.019	0.209	330	2174	0.150
5	39.1	2174	85.019	0.209	330	2174	0.150
6	39.1	2174	85.019	0.209	330	2174	0.150
7*	39.1	2174	85.019	0.209	330	2174	0.150
8	39.1	2174	85.019	0.209	330	2174	0.150
9	0.2	2174	0.435	0.392	303	2174	0.258
10	0.2	2174	0.435	0.392	303	2174	0.258
11*	0.2	2174	0.435	0.392	303	2174	0.258
12	0.2	2174	0.435	0.392	303	2174	0.258
13	0.2	2174	0.435	0.392	303	2174	0.258
14	0.3	2174	0.652	1.202	340	2174	0.889
15	0.3	2174	0.652	1.202	340	2174	0.889
16*	0.3	2174	0.652	1.202	340	2174	0.889
17	0.3	2174	0.652	1.202	340	2174	0.889
18	0.3	2174	0.652	1.202	340	2174	0.889
19	1	2174	2.174	1.113	330	2174	0.799
20	1	2174	2.174	1.113	330	2174	0.799
21*	1	2174	2.174	1.113	330	2174	0.799
22	1	2174	2.174	1.113	330	2174	0.799
23	1	2174	2.174	1.113	330	2174	0.799
24	1	2174	2.174	1.113	330	2174	0.799
25	0.4	2174	0.870	0.603	343	2174	0.450
26	0.4	2174	0.870	0.603	343	2174	0.450
27	0.4	2174	0.870	0.603	343	2174	0.450
28	0.4	2174	0.870	0.603	343	2174	0.450
29	0.4	2174	0.870	0.603	343	2174	0.450
30*	0.4	2174	0.870	0.603	343	2174	0.450
Total			478.803				14.045

*Day of sample collection

Percent MT released from the overflow water in each day was calculated from mass of MT in each phase divided by total mass of MT released from the overflow water as shown in Table B-3

Table B-3 Percent MT released in water phase and suspended solid phase released in each day from the overflow water

Day	Percent MT released from overflow	
	Water phase	Sus-s phase
1	99.766	0.234
2	99.766	0.234
3	99.766	0.234
4	99.824	0.176
5	99.824	0.176
6	99.824	0.176
7	99.824	0.176
8	99.824	0.176
9	62.740	37.260
10	62.740	37.260
11	62.740	37.260
12	62.740	37.260
13	62.740	37.260
14	42.332	57.668
15	42.332	57.668
16	42.332	57.668
17	42.332	57.668
18	42.332	57.668
19	73.137	26.863
20	73.137	26.863
21	73.137	26.863
22	73.137	26.863
23	73.137	26.863
24	73.137	26.863
25	65.916	34.084
26	65.916	34.084
27	65.916	34.084
28	65.916	34.084
29	65.916	34.084
30	65.916	34.084

BIOGRAPHY

NAME : Miss Kanyaratt Waiyaput
DATE OF BIRTH : 18th September 1986
PLACE OF BIRTH : Bangkok, Thailand
HOME ADDRESS : 77/104 Moo1 Surasak, Sriracha, Chonburi, Thailand,
20110
CELL : + 6689 7716887
E-MAIL : kanyaratt.w@gmail.com
EDUCATION : Bachelor Degree of Environmental Engineering,
Chulalongkorn University,

RESEARCH EXPERIENCE :

Kanyaratt Waiyaput and Puntisa Viriyarat. Studying Ammonia Oxidizing Bacteria and Ammonia Oxidizing Archaea communities in an aerated lagoon and activated sludge system. Undergraduated senior project, Department of Environmental Engineering, Chulalongkorn University, 2008

Kanyaratt Waiyaput, Natchanun Leepipatpiboon, Say Kee Ong, and Tawan Limpiyakorn. Determination of 17 α -methyltestosterone in masculinization Nile tilapia ponds. The third Conference in Environmental Science, Engineering and Management, Bangkok, 2011, pp 17-18. Bangkok: Chulalongkorn University, 2011.

