

CHAPTER II

HGA MANUFACTURING PROCESS

2.1 Introduction

Seagate disc and tape drive products are the basis of any information solution. Worldwide Seagate disc and tape drive products store and reliably retrieve information billions of times every day. An information solution can be as complex as an enterprise network storage system or as complex in different ways as a notebook computer. In every case, Seagate storage products reliably store, retrieve and deliver the information people need to meet their information solution requirements. Disc drive is an important storage product that makes a lot of profits to Seagate. Disc drive is comparable to the brain of human that has the memory for the various kinds of information in disc and tape drive. And there are many Head Gimbal Assembly (HGAs) inside which are the important components of Disc drive because their main functions are to store and retrieve the information recorded on the media or discs installed in disc drives. HGAs can be divided in to two types, up tab and down tab. Up tab is HGA facing up to media and down tab is HGA facing down to media.

2.2 HGA Components

Head Gimbal Assembly (HGA) is the major component of Hard Disc Drive that is installed in computer for storing and retrieving the information. Therefore, reliability of storing or retrieving the information mainly depends on HGAs.

HGA is composed of four components as the followings;

- 1) **Slider** is an important component of HGA and disc drive. Because it records and reads the information on the media in disc drive.
- 2) **Flexure** (Suspension) is the body of HGA which is flexible for flying on the media.
- 3) **Flex on Suspension** (FOS) is circuit on HGA and also has the connectors to connect the slider and PCC of HSA (Head Stack Assembly).
- 4) **Damper** is attached on the load arm of flexure to reduce torsion of arm that may cause resonance problem when the HGAs are operating in disc drive.

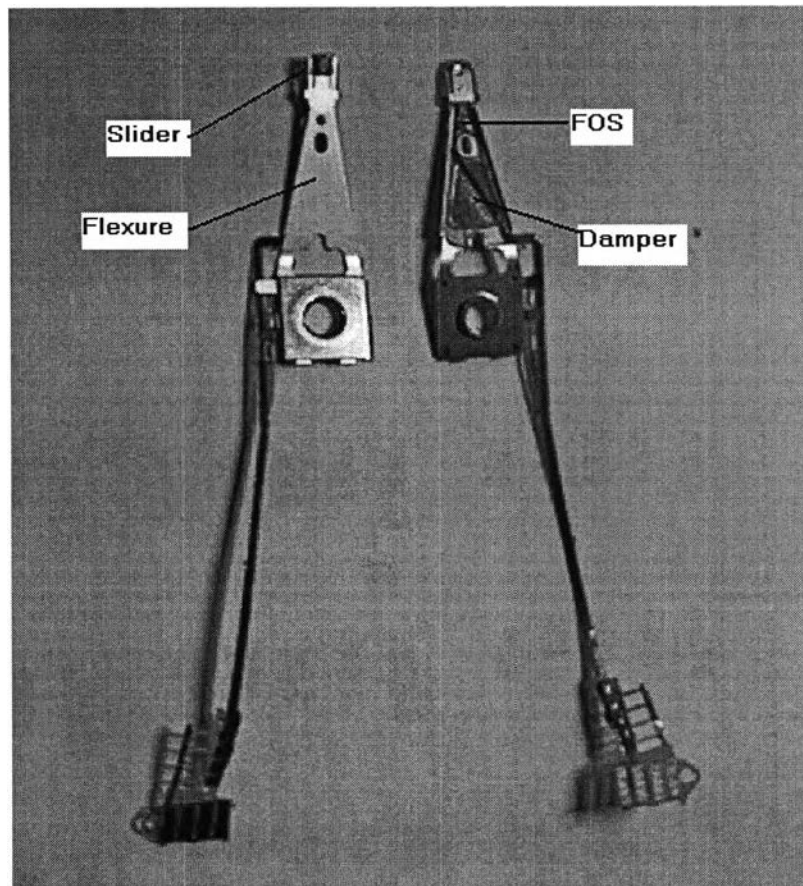

Figure 2.1 The components of HGA are slider, flexure, FOS, and damper.

2.3 HGA Process Flow

Although HGA will be composed of only four components but its assembly process is very complex and also need much facilities. In the HGA manufacturing process flow, there is not only the assembly line but there is also the testing & inspection line included in HGA manufacturing process flow. That is because Seagate need to ensure that the finished goods will not include defects and to guarantee the product that Seagate storage products reliably store, retrieve and deliver the information as users' requirements. The operation flow is shown as Figure 2.2.

Ultra4 HGA Operation Flow

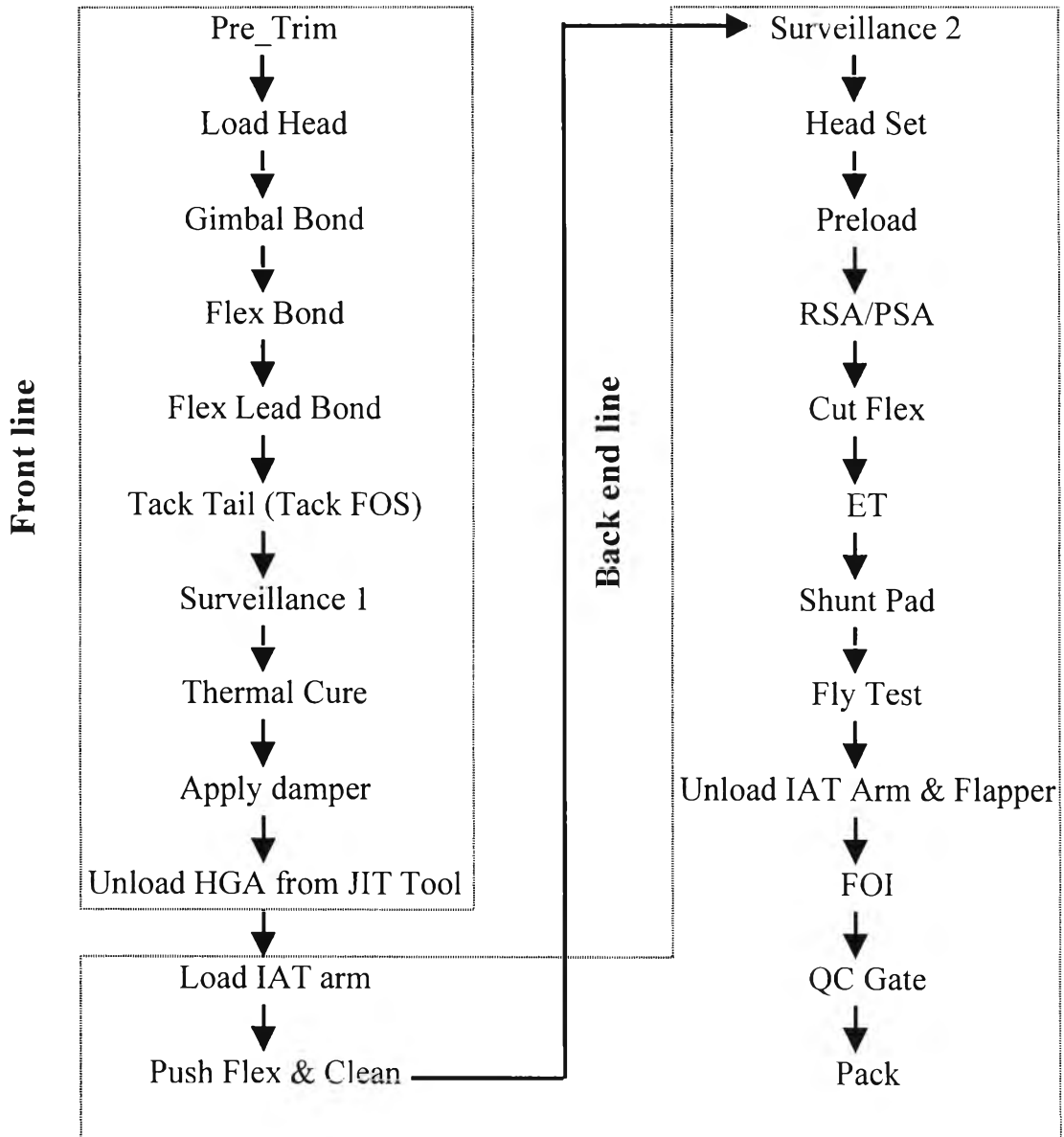

Figure 2.2 Ultra4 HGA operation flow.

Process Details¹

Pre-Trim FOS

This process is to trim the FOS lead capture prior to flex by positioning the flex on the fixture insert by placing the front tooling hole and the back slot of the flex on the guiding pins (Figure 2.3). At this position, the lead capture is hanging under the cutting blade. And then cut the lead capture by pressing the blade handle. Place the flex back into the tray and stage for next operation.

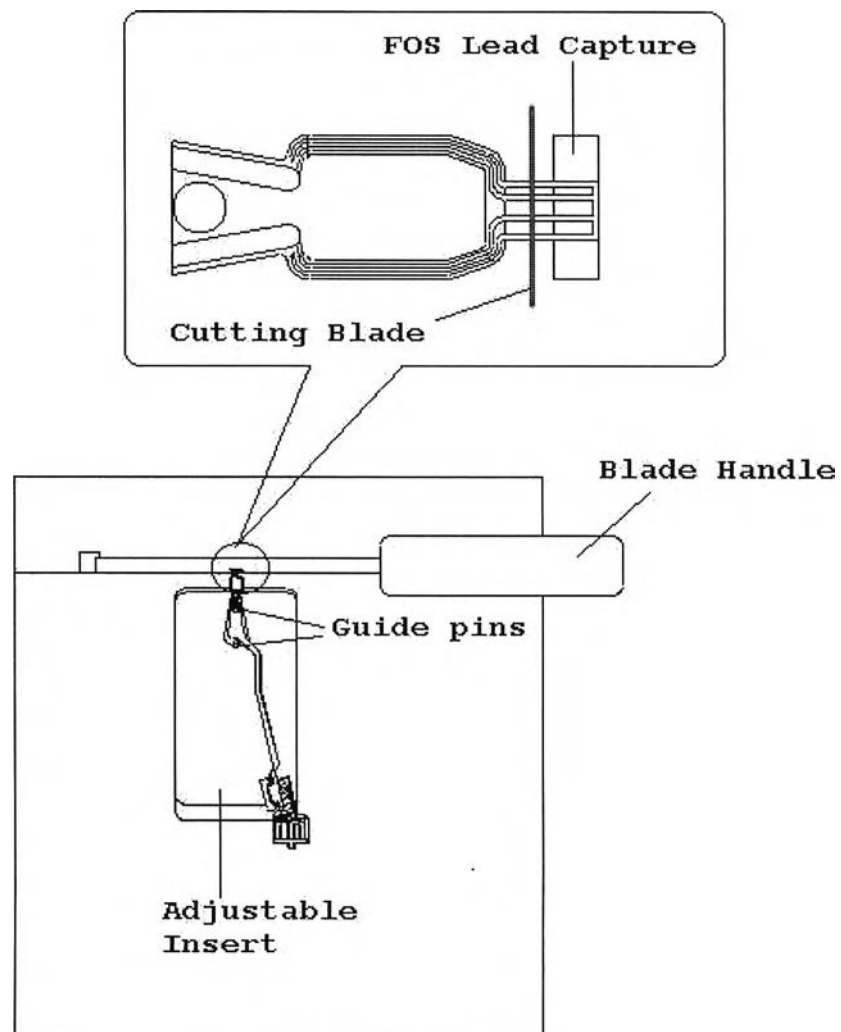
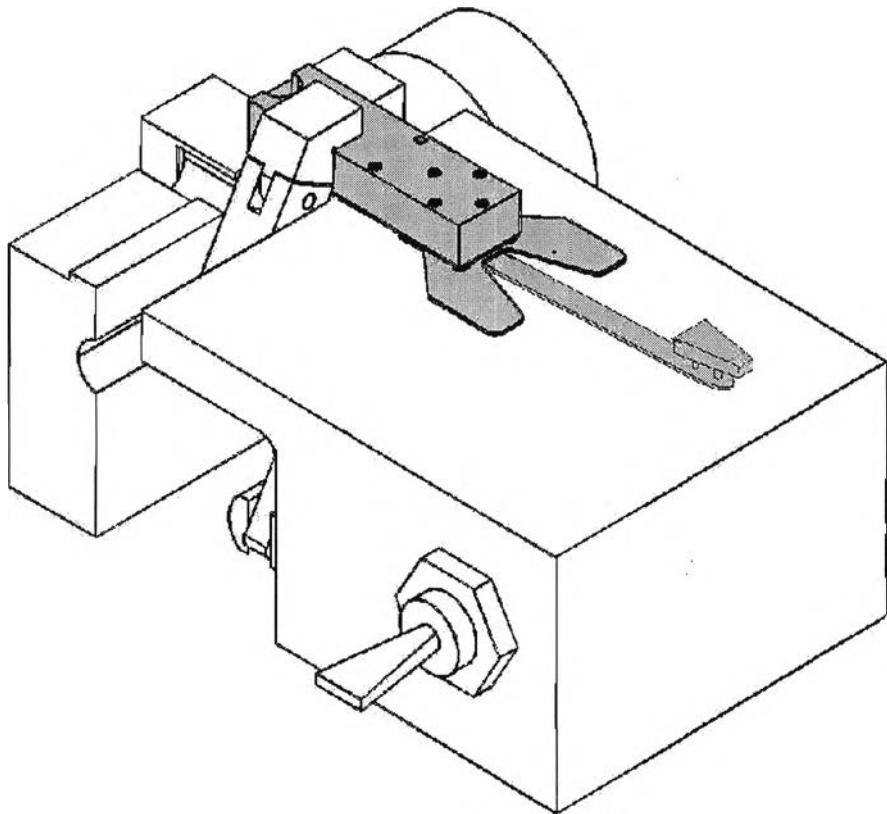

Figure 2.3 Pre-trim lead fixture.

¹ Manufacturing Process Document.

Load Head

This process is to load 30-series sliders into JIT tools using an inverted-style head loader. Turn the JIT tool upside down (suspension Clamp/Flex clamp down) and place the JIT tool in between the JIT clamp and the alignment pins. With the end of the tweezers apply a light pressure on the trailing end of the slider. While holding the slider in place actuate the toggle switch to clamp the slider and release the JIT clamp. Remove the JIT tool from the inverted loader. Turn it right side up (suspension clamp/Flex clamp up) and place it in the oven tray.



(JIT TOOL SHADED)

Figure 2.4 JIT Tool sitting in head load Fixture.

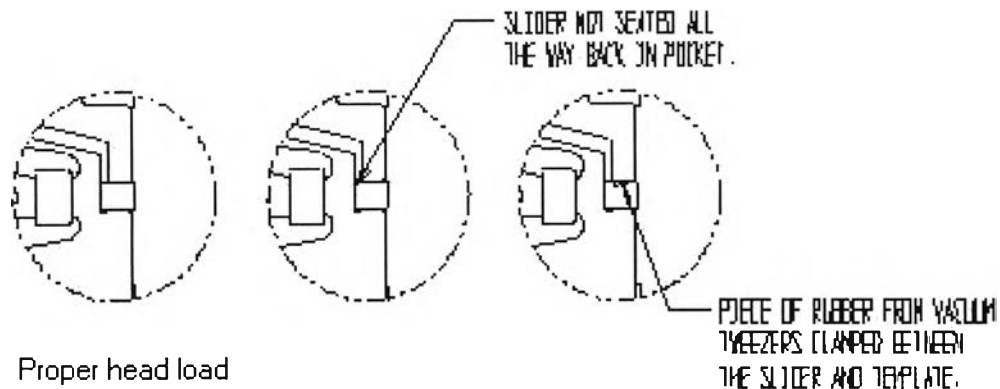

Figure 2.5 slider sitting in pocket of JIT Tool.

Gimbal Bond

This process is to bond the flexure (suspension) to the slider using Ablebond 8385 adhesive. This process will focus on bonding strength. Adhesive must be strong enough to bond the slider stick on flexure because there will be much friction performed on the slider when it is flying on the media.

Flex Bond

This process is to bond the FOS to the suspension using Hysol LD227. It does not require much strength because there is no force performed on the FOS. It is just to stick the FOS on the suspension.

Flex Lead Bond

This process is to form and align the flex leads, then ultrasonically bond the flex leads to the gold bond pads on the trailing end of the MR head. This is to connect the circuit to the slider because the flex leads perform themselves as the connectors between the circuit on FOS and slider. One side of connectors called flex leads will be bonded to the gold bond pads of slider as shown in Figure 2.6.

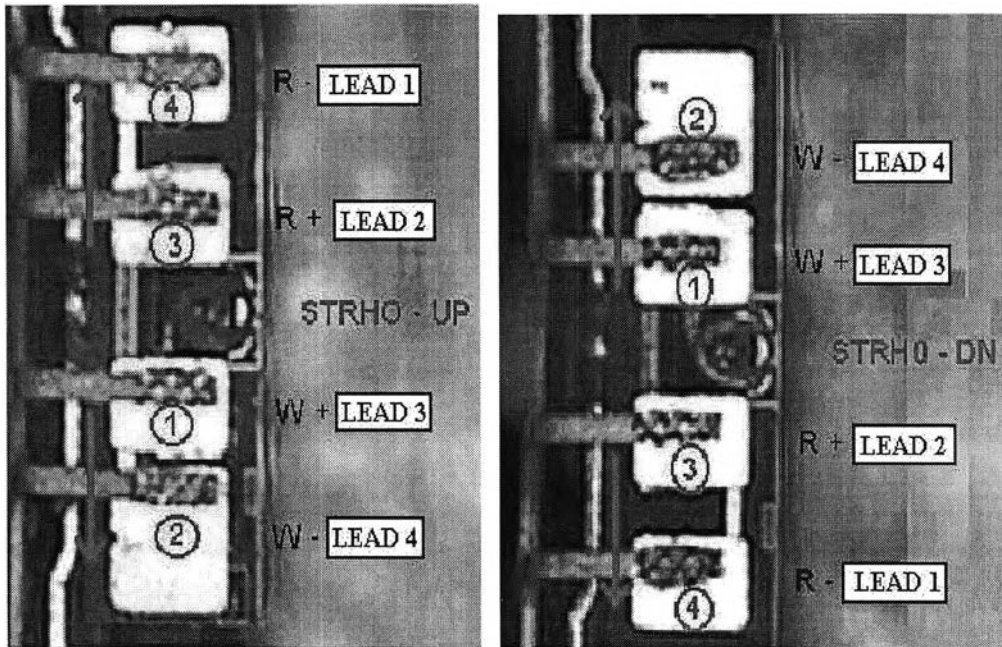

Figure2.6 flex leads bonded to the gold bond pads of sliders.

Tack Tail

This process is to attach the tail of the flex to the load arm capture using Hysol LD227 by applying adhesive to the flex in the area which covers the formed tab.

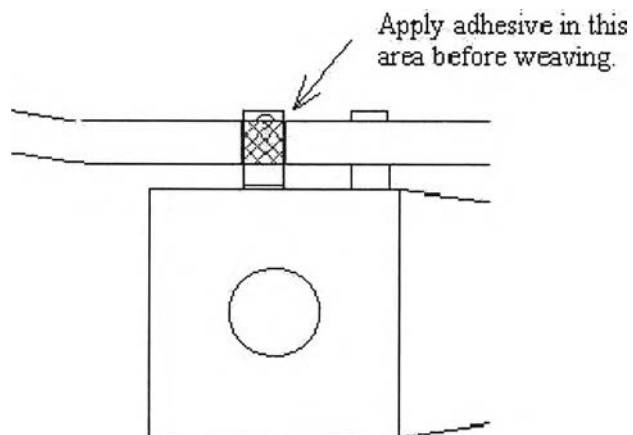

Figure2.7 the tail location that adhesive will be applied on it.

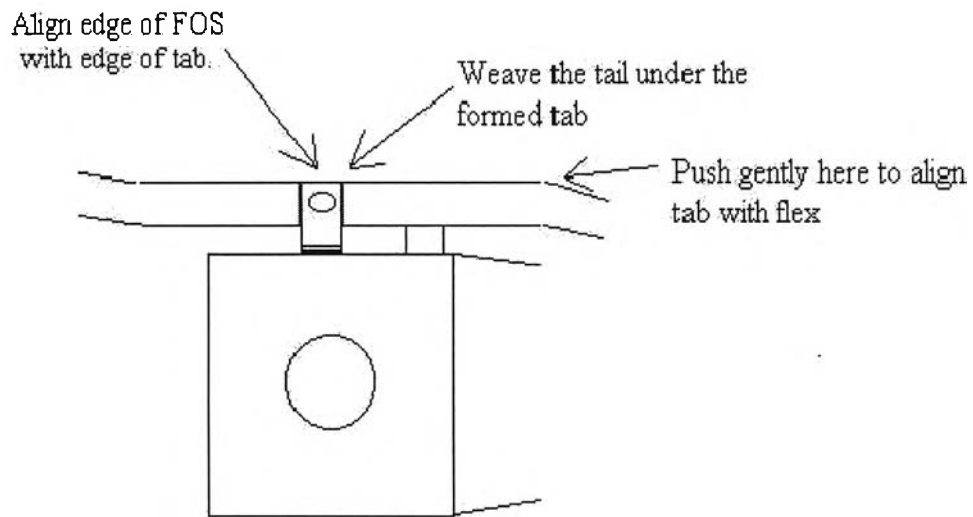

Figure 2.8 tail is already weaved under the formed tab.

Surveillance 1

This process is performed to inspect the HGAs in terms of mechanical that may be created from the front line assembly. The operators at this operation will inspect the parts as many as possible (maximum their capacity). Whenever, they find some defects they will feed back and alert the concerned operations.

Oven Cure

This process is to cure the all kind of adhesive which are applied to bond slider Suspension and FOS together.

Damper

This process is to manually apply a damper to the HGA load arm. The damper applied on HGA will reduce torsion of load arm that effects the resonance at Drive level.

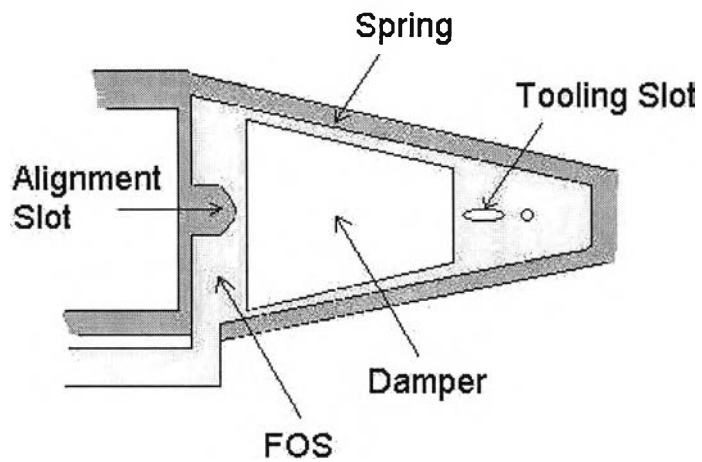

Figure 2.9 damper Placement on HGA.

Unload JIT Tool

This process is to unload a 30-series HGA from the JIT tool. The parts that are removed from the JIT Tools will be the completed HGAs but they need to be tested and inspected.

Load IAT Arm

This process is to load complete HGA onto the IAT test arm. IAT test Arm is used as carrier and fixture at the same time.

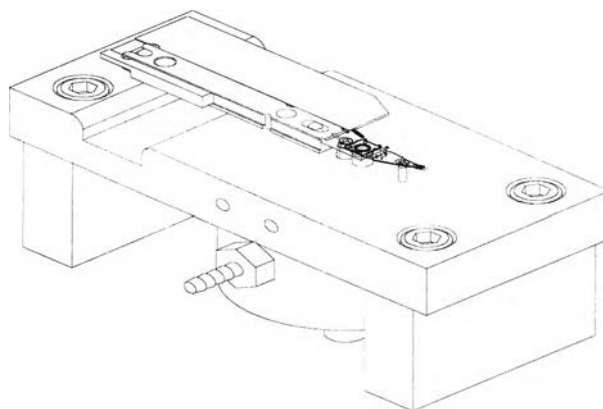

Figure2.10 HGA loaded to IAT arm on fixture.

Push Flex and Spot clean

This process is the combination of two processes. The first one is to pin the flex onto the IAT test arm. This is to fix the connector of HGA to align with pogo pins at testers. And the second process is spot clean that is to inspect contamination on the parts and clean them out if the operators find any contamination prior to test. This will ensure that contamination will not degrade the parts at electrical test station and does not cause the disc scratch.

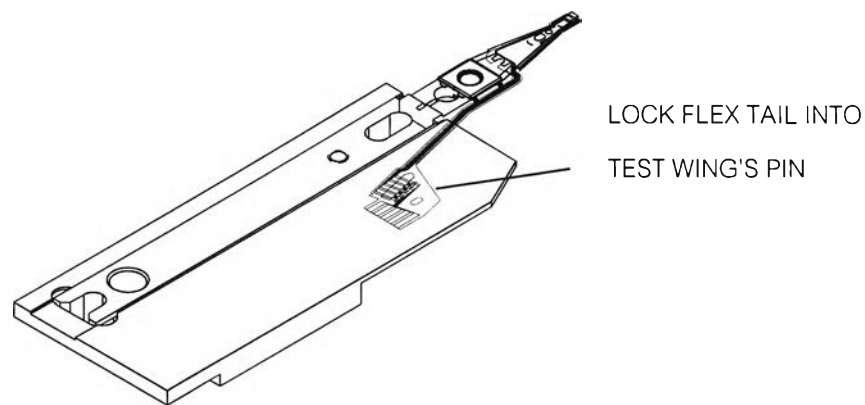

Figure 2.11 the location of flex tail that will be locked into test wing.

Surveillance 2

This process is performed as Surveillance 2. The operators at this operation have to inspect the HGAs as many as they can.

Head Set

This process is to perform head set on HGA. In the other word, it is to set the domain of permanent magnet inside the slider to align it to the same and desired direction.

Autogram

This process is to measure and adjust the gram load of the HGA load arm using the automated preload station ("Auto-Grammer"). Due to gram load of HGA load arm is very sensitive to the distance between the parts and media (Fly height) and will directly affect to the performance of store and retrieve the information on the media. The gram load of all HGA load arm have to be within the target windows.

SAAM

The Static Attitude Adjust Machine (S.A.A.M.) measures and adjusts HGA static attitude. HGA static attitude is measured according to IDEMA document 194. The definitions of positive PSA and RSA are illustrated in Figure 2.11. Positive PSA rotates the trailing edge closer to the disc. Positive RSA is counter clockwise rotation as viewed from the trailing end. As mentioned in Autogram operation, SAAM is also very sensitive to the head performance the parts, therefore, have to be measured and be adjusted to be within SAAM target windows.

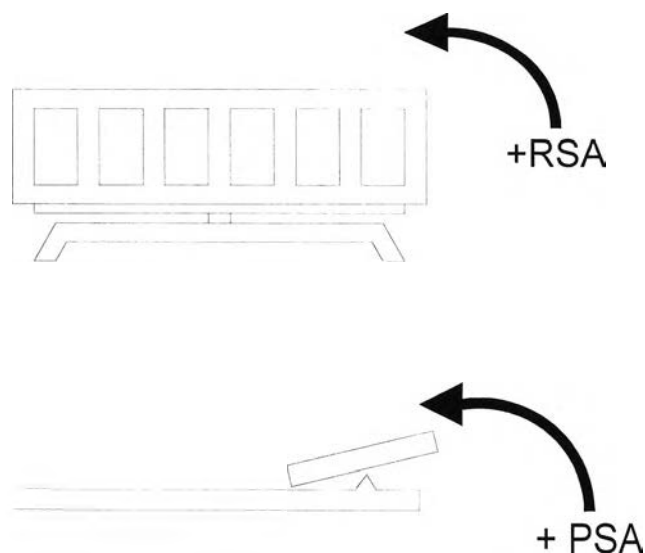

Figure 2.12 the characteristics of RSA and PSA of HGA.

Cut FOS

This process is to trim the shunt of a FOS on an HGA. This shunt is manufactured with FOS manufacturing. It will make the same potential voltage among four leads of FOS to protect the part damaged due to ESD (Electro Static Discharge).

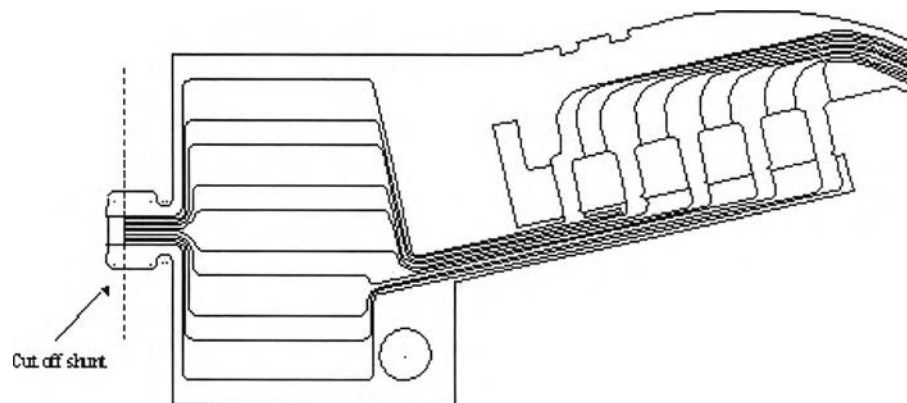

Figure2.13 the shunted tab that will be cut off before the parts are sent to test.

Electrical Test

This process is to test the HGAs in terms of electrical test. This test is performed on the electrical tester to test the performance of store and retrieve the data on media. Furthermore, some parameters are tested to see the stability of heads. They will show the reliability of HGAs in storing and retrieving the information.

Shunt

The purpose of this process is to apply a shunt (used to help prevent ESD damage) with the FOS Auto-shunt machine after the parts are completely tested at the electrical tester and it will be removed again after the HGAs are installed in HSAs (Head Stack Assembly)

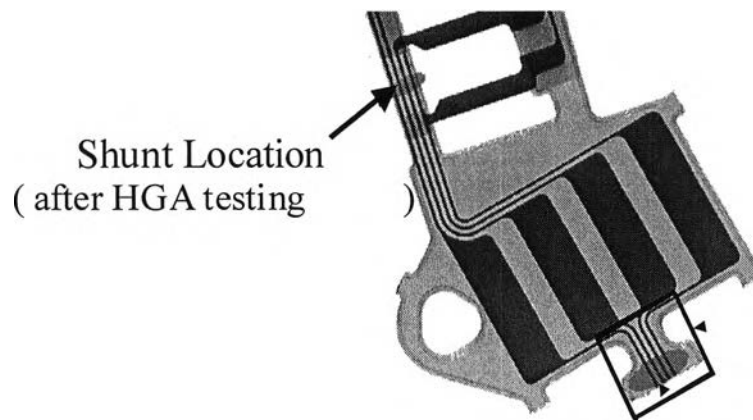

Figure 2.14 The location on flying lead that will be shunted all traces together to protect ESD damaged.

Fly Test

This test is performed to test fly height of the heads while they are on operating media. They are tested on the fly tester. Due to Fly height is sensitive to storing and retrieving the data. Too low fly height may cause disc scratch that results in some track of information on media (disc) damaged. And too high fly height may cause low magnetic density to store and retrieve the data from media.

Fold Flapper

This process is to fold the flapper on the flex tail of an HGA mounted on an IAT test arm.

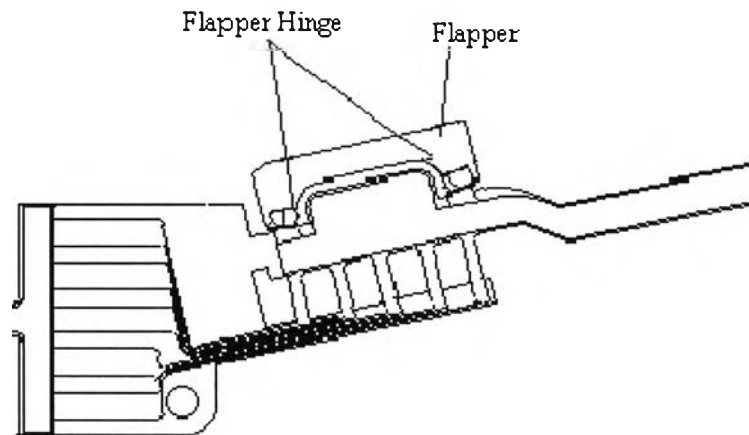

Figure2.15 The picture of flapper on flying lead.

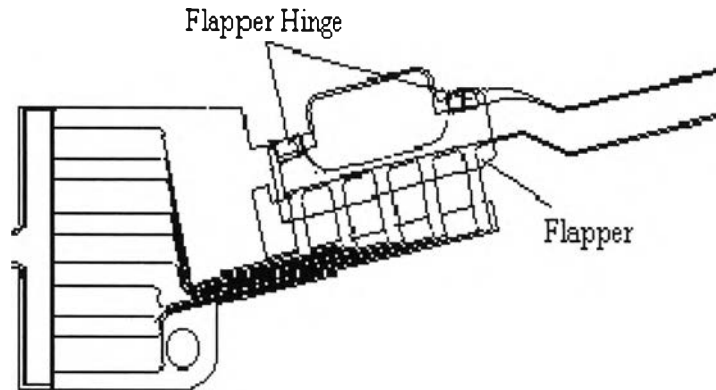

Figure 2.16 Flipper is already folded at flapper hinge.

Unload IAT Arm

This process is to unload the HGA from the IAT test arm after the parts are already tested.

Aqueous

This process is concerning with Automatic Cleaning System to clean HGAs before they are sent to the customer. The parts will be put into the special trays (Clean & Ship tray) and send to the cleaning system for cleaning. There are totally six tanks at the Aqueous. The first tank contains the solvent of soap and the next three tanks are the DI water for removing soap. After that the parts will be moved to the fifth tank which install the hot air blower inside. To reduce the humidity on the HGAs, the parts will be moved to the last tank that is the vacuum tank.

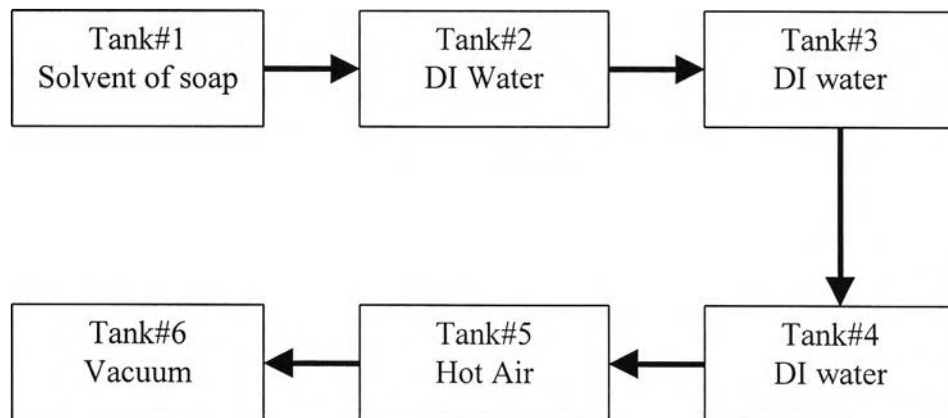

Figure2.17 Cleaning system of Aqueous that contains six tank for HGA cleaning.

Final Inspection (FOI)

This process is to visually inspect the HGA after Test to sort out the mechanical defects. The inspectors will inspect the HGAs in term of mechanical related by reference to product criteria that states the specification of HGAs.

2.4 Standard Work & Standard Time

The current standard work and standard time called standard UPH (Unit per Hour) was studied and set since product was run with 100% learning curve by Industry Engineer (I.E.). See Table 2.1. This information was used to study the opportunity to improve the product capacity.

The standard UPH table contains six important columns as followings;

Operation will tell the names of each operation in the Ultra4 HGA process flow that will be concerned with assigned task at such operation. Each operation stated in each row will be ordered as process flow.

Sampling will tell the percentage of total loading that is performed at each operation. For example, 100% at Flex lead bond means that **all** of HGAs loaded into the assembly line will be performed at flex lead bond operation and 28% at Surveillance1 means that **only 28%** of total loading will be inspected by surveillance1.

UPH stand for Unit Per Hour. It will tell the average number of HGAs that will be performed by one operator at such operation within an hour.

H/C stand for head count. In the other word, it means the numbers of operators who are assigned to do the job at each operation. This head count is concerned with two issues. The first one is concerned with line balancing. This can be considered by the idle time. The second one is also the space limitation.

%UTL stands for the percentage of utilization of such operation. Seven working hours in each shift will be separated into two categories. The first one is for %allowance which is the percentage of working time that allow the operators to relax, go to rest room and the activities that do not create the job. Normally Seagate apply %allowance at 10%. And the rest is %Utilization that is the percentage of working time that the operators really do the job. Therefore, the capacity of each operation must consider this % utilization.

Capacity is the numbers of parts that can be performed at each operation. The capacity will be calculated from sampling, standard UPH, the number of operators at such operation, and %utilization. For example, the capacity of damper operation can be calculated as below.

| | | |
|--------------|---|---|
| Sampling | = | 100% |
| UPH | = | 248 |
| Head count | = | 3 operators |
| %Utilization | = | 90% |
| Capacity | = | 248 UPH * 3 Operators * 3 shifts per day * 90%Utl * 7 Hours |
| | = | 14,062 units per day |

%Eff is the percentage of efficiency. It means the ratio of loading compared to the capacity of that operation. In the other word, this is comparing the numbers of parts that are really produced at such operation to the numbers of units that such operation can produce. In case of damper operation, this operation can, actually, produce 14,062 units per day because of bottle-neck operation only 10,500 units per day were planned to load into the assembly line. Therefore, %efficiency of damper operation is 10,500 divided by 14,062 or 75%efficiency.

%Idle is opposite %Eff. It is the ratio of the rest of its capacity compared to its capacity. In case of damper operation, %idle is $100 - 75 = 25\%$.

Standard UPH

Product: Ultra4 HGA

| Operation | Sampling | UPH | Standard loading 10.5 | | | | | Remark |
|-------------------------------------|----------|------|-----------------------|------|----------|------|-------|----------|
| | | | H/C | %UTL | Capacity | %Eff | %Idle | |
| PRE-TRIM | 100% | 662 | 1 | 90% | 12,512 | 84% | 16% | |
| LOAD HEAD | 100% | 340 | 2 | 90% | 12,852 | 82% | 18% | |
| CUT FLEX | 100% | 870 | 1 | 90% | 16,443 | 95% | 5% | |
| FLEX BOND | 100% | 111 | 1 | 90% | 10,549 | 96% | 4% | |
| FLEX LEAD BOND | 100% | 236 | 3 | 90% | 13,381 | 78% | 22% | |
| TACK TAIL (TACK LOSS) | 100% | 0 | 1 | 90% | 10,549 | 100% | 0% | |
| SURVEILLANCE 1 THERMAL OVEN CURE | 28% | 160 | 1 | 90% | 10,800 | 97% | 3% | Max Cap. |
| APPLY DAMPER | 100% | 248 | 3 | 90% | 14,062 | 75% | 25% | |
| UNLOAD HGA FROM JIT TOOL | 100% | 382 | 2 | 90% | 14,440 | 73% | 27% | |
| LOAD IAT TEST ARM | 100% | 340 | 2 | 90% | 12,852 | 82% | 18% | |
| PUSH FLEX OVER PIN&CLEAN | 100% | 181 | 4 | 90% | 13,684 | 77% | 23% | |
| SURVEILLANCE 2 | 28% | 160 | 1 | 90% | 10,800 | 97% | 3% | Max Cap. |
| HEAD SET | 100% | 730 | 1 | 90% | 13,797 | 76% | 24% | |
| PRE LOAD | 100% | 187 | 4 | 90% | 14,137 | 74% | 26% | |
| RSA/PSA | 100% | 175 | 4 | 90% | 13,230 | 79% | 21% | |
| CUT FLEX | 100% | 870 | 1 | 90% | 16,443 | 64% | 36% | |
| ET | 100% | 0 | 1 | 90% | 10,549 | 99% | 1% | |
| SHUNT PAD | 100% | 524 | 1 | 90% | 12,380 | 85% | 15% | |
| FLY TEST | 1% | 50 | 1 | 90% | 135,000 | 8% | 92% | |
| UNLOAD IAT ARM & FLAPPER | 100% | 295 | 2 | 90% | 13,939 | 75% | 25% | |
| FOI | 100% | 128 | 4 | 90% | 12,096 | 87% | 13% | |
| QC GATE (OBA) | 20% | 128 | 1 | 90% | 15,120 | 69% | 31% | |
| PACK | 100% | 1500 | 1 | 90% | 35,438 | 30% | 70% | |
| MRB SCREEN | 8.10% | 666 | 0 | 90% | - | | | |
| Total in line H/C | | | 45 | | | | | |
| | | | 53 | | | | | |

Table2.1 Current standard UPH of all operations in Ultra4 product.

2.5 Critical Operations

From reviewing the standard UPH in Table2.1, the capacity of each operation is summarized in the Bar chart as Figure2.18.

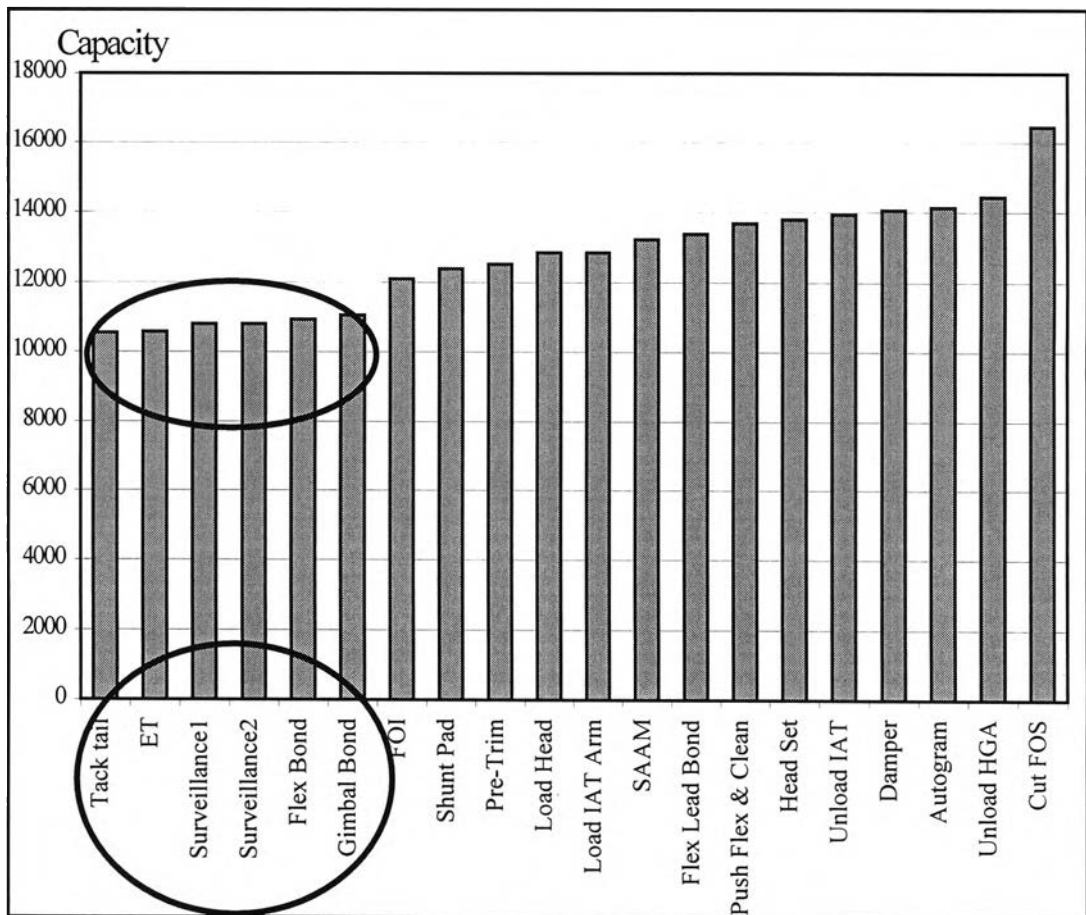

Figure2.18 Bar chart of the operation capacity of each operation in Ultra4 HGA assembly process ranking from the least capacity.

From the Bar chart, there are totally six operations that have the least capacity. The reasons why those six operations were selected are their capacities are the similarly least capacities.

- 1) **Tack tail** is the bottleneck of the Ultra4 HGA assembly line because this operation performs with 100% efficiency. In the other word, the idle time is zero. All HGAs have to be assembled through this operation. Although Tack tail operation is running with 91% utilization that is more than other operations running with 90% utilization but this operation can produce only 10,549 HGAs per day (three shifts). That is because its standard UPH is 276 but it contains 2 operators per cell per shift.
- 2) **ET (Electrical Test)** is the one operation that is in the top two % efficiency in six operations. Its efficiency is 99% that can test 10,594 HGAs per days with seven electrical testers. But loading is only 10,500 HGAs per day so the idle time of this operation is 1 %. The electrical testers are set at the special lines containing electrical testers only and the stations can be added to support the unlimited capacity. This operation, therefore, is not the critical operation that need improvement. Furthermore, it was also stated in the scope of study that this study will not cover the electrical test.
- 3) **Surveillance1:** This operation is to inspect the HGAs in term of mechanical defect. The operators at this operation will inspect as many parts as they can. With the standard UPH of 160, they can inspect 3,024 HGAs per day or 1,008 HGAs per shift. In the other word, they will inspect only 28% of total loading. Because this operation performs with sampling plan it is not, therefore, concerned with the capacity improvement.
- 4) **Surveillance2:** This operation performs as Surveillance1. Therefore it is not concerned with the capacity improvement too.

- 5) ***Flex Bond*** contains 3 stations operated by 3 operators per cell per shift. The standard UPH of this operation is 193. In the other word, one operator can produce 193 HGAs per hour. In one day, this operation can assemble 10,943 HGAs. So that this operation is the top five of high %efficiency which was running with 96% efficiency. That means the idle time of this operation is 4%.
- 6) ***Gimbal Bond*** also contains 3 stations operated by 3 operators per cell per shift as same as Flex bond operation performs. The standard UPH of this operation is 195. In the other word, one operator can produce 195 HGAs per hour. In one day, this operation can assemble 11,057 HGAs. So that this operation is the top six of high %efficiency which was running with 95% efficiency. That means the idle time of this operation is 5%.

From reviewing six operations selected by using the Bar Chart by ranking from the least capacity, there are finally only three operations that are the critical operations for capacity constraint. **Those three operations are Tack tail, Flex bond, and Gimbal bond.** Those operations are the value-added operations. That means that there may be the functional effect if there are some changes at those operations. Therefore, everything that will be changed or be developed must be evaluated the related functional effect.