



## CHAPTER 4

### THE IMPLEMENTATION OF MODIFIED FMEA

#### 4.1 The result of suggestion activity

In the suggestion activity, the technicians from all of process area will be assigned to consider the points that are the sources of loss of energy in their responsible process areas. In the analysis, each process area is divided into sections by using process flow diagram in order to make it efficient for analysis as shown in table 4.1. In each section, the small group that is assigned to analyze the failure mode will consider on the point or equipment that may be the cause of loss of energy and list into the modified FMEA form as shown in Appendix I

*Table 4.1: Failure mode analysis dividing section*

Unit	Section code	Description
VDU	VDU-1	Feed preheating section
	VDU-2	Heater section
	VDU-3	Vacuum distillation column
	VDU-4	Stripping section
PDA	PDA-1	Feed/Extraction section
	PDA-2	DAO recovery section
	PDA-3	Solvent recovery section
	PDA-4	Asphalt recovery section
MPU	MPU-1	Feed/Extraction section
	MPU-2	Raffinate recovery section
	MPU-3	Extract recovery section
	MPU-4	Solvent recovery section
HFU	HFU-1	Feed/Reactor section
	HFU-2	Stripping section
	HFU-3	Hydrogen section
SDU	SDU-1	Feed chilling section
	SDU-2	Filter section
	SDU-3	DWO recovery section
	SDU-4	SLW recovery section
	SDU-5	Solvent recovery section
BBU	BBU-1	Feed/Reactor section
	BBU-2	Off gas section
Utility	UT-1	Cooling water
	UT-2	Instrument air
	UT-3	Steam/Condensate
	UT-4	Hot oil heater
	UT-5	Sour water treating

*Note See detail in process flow diagram in Appendix J*

From the list of failure modes in Appendix I, the potential failure modes that are possible and reasonable to proceed are selected by the working team as following.

- 1) *Loss of fuel oil and steam from furnace:* At the VDU and Hot oil system's furnaces, we always find that the percent of excess Oxygen remaining from combustion is around 5% of total flue gas. From theory, the optimum point excess Oxygen is around 2.0% – 2.5%. It means that if the excess Oxygen can be reduced, the fuel oil and steam used from the furnaces can also be reduced. Figure 4.1 shows the working of the furnace.

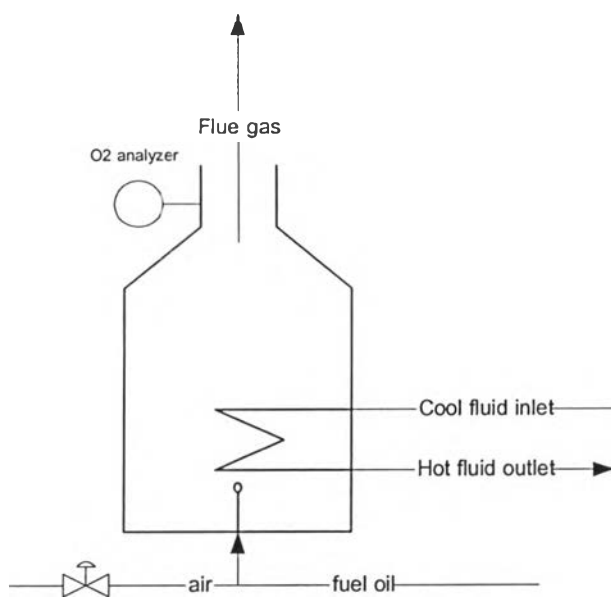

**Figure 4.1: The working of the furnace**

- 2) *Loss of steam in sour water stripping unit:* The function of sour water stripping unit (SWS) is to remove Hydrogen Sulfide ( $H_2S$ ) and Ammonia gas from the wastewater before sending to wastewater treatment process. In this unit steam is injected to the stripping column to strip the sour gases. From the calculation, the optimization ratio of steam used and sour water is 1 ton of steam per 10 tons of sour water. But from the record, the steam is always used more than optimum point that causes the loss of steam. The diagram of SWS is shown in figure 4.2.

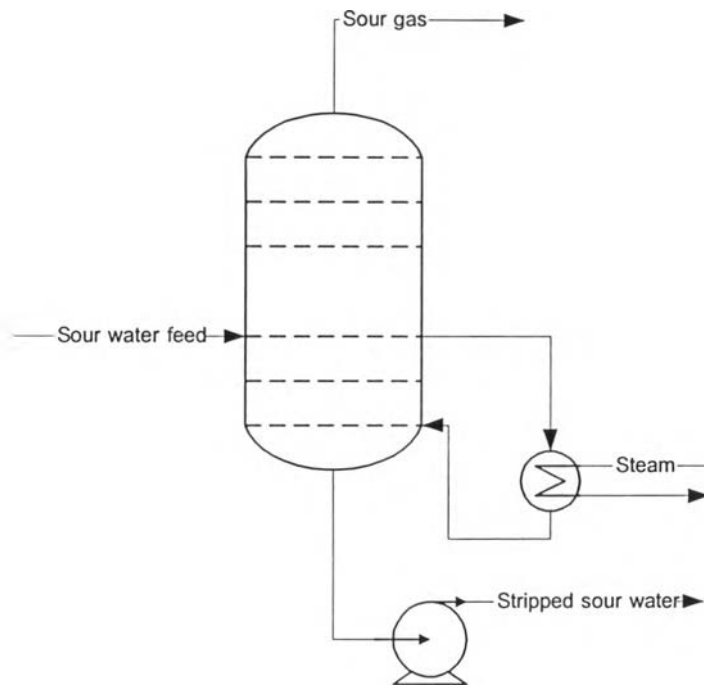

**Figure 4.2: The sour water stripping unit**

- 3) *Loss of steam in the tracing system:* The steam used to warm the pipeline that contains high viscosity fluid is called steam tracing. The steam that is condensed from the warming line will be trapped by steam trap. If the steam trap is not working properly, it will allow the steam that is not used go with the condensed steam that causes the loss of steam. Figure 4.3 shows the steam tracing system's working

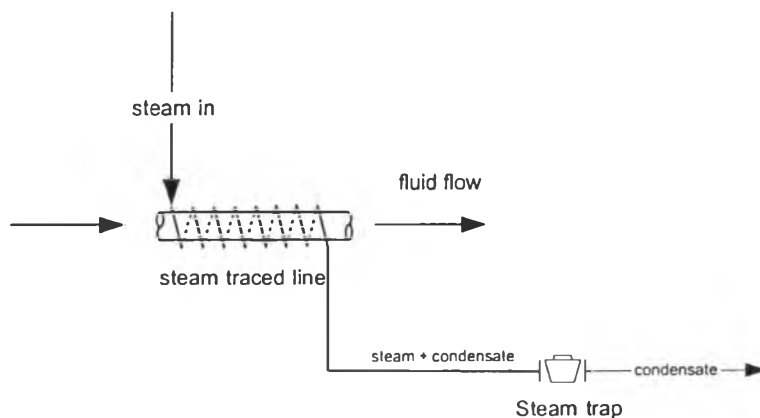

**Figure 4.3: The working of steam tracing**

- 4) *Loss of electricity from the lighting of the dewaxing filter:* The filters used to separate petroleum wax from oil in the solvent dewaxing unit have many lamps to see the forming of wax crystal in the filter cloth. From the present practice, the only half of lighting system has been used all time but the another half is rarely used that is the loss of energy if the both sides of lighting must be turned together every time. The dewaxing filter is shown in figure 4.4.

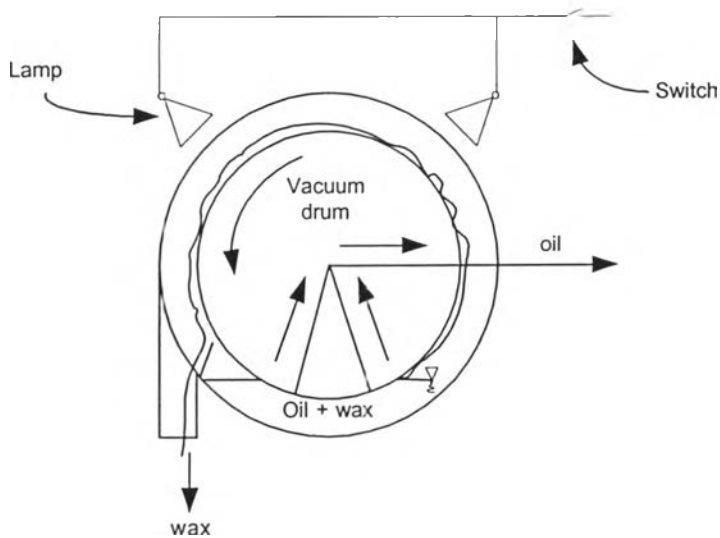

**Figure 4.4: Dewaxing filter**

- 5) *Excess air from bitumen blowing unit (BBU):* In the bitumen blowing process, compressed air from air compressor will be injected to the bitumen blowing tower to oxidized the light hydrocarbon compound in the bitumen feed. With the process design, both units have their air compressors and when both units are run, the excess compressed air is vented to the atmosphere that is the loss of electricity.

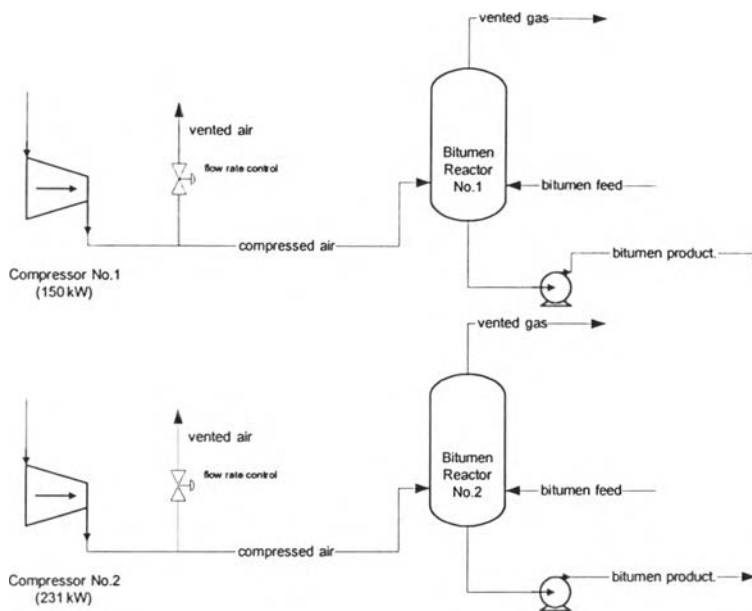

**Figure 4.5: Bitumen blowing unit diagram**

- 6) *Excess air from instrument air compressor:* The instrument air compressor is used to supply compressed air to control the opening of control valves. It is found that the excess air is always vented to the atmosphere that is the loss of electricity.
- 7) *The excess of cooling water's temperature:* The cooling water system is used to supply water to remove heat from process and the high temperature returned from the process will be cold by cooling fans. The design temperature of supply water is 32°C but from the record the supply water's temperature is always lower than 30°C that is the loss of energy.

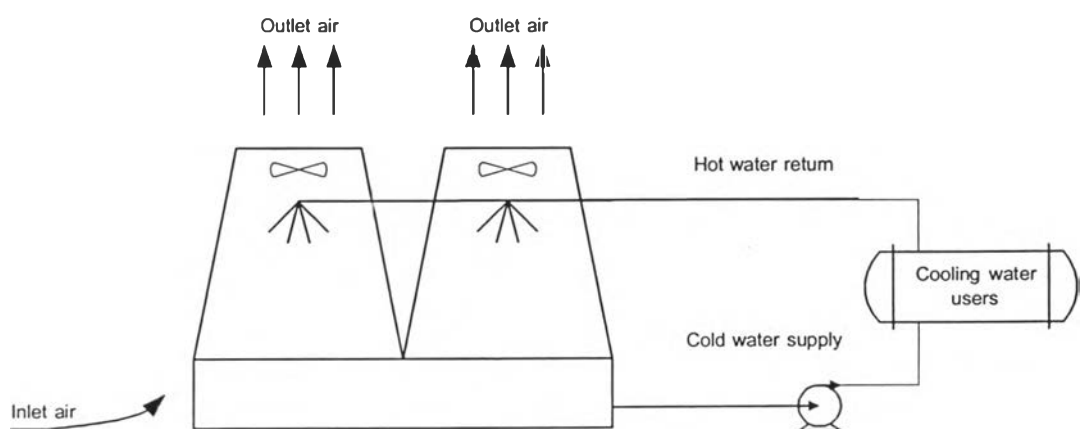

**Figure 4.6: Cooling water system diagram**

- 8) *Loss of energy from air fin cooler (AFC):* The AFC is the equipment that is used to remove heat from process by using air. Many temperature control systems in the process use control valve to control the flow through the AFC to control the fluid's temperature (see figure 4.7) that make the energy used in AFC is not utilized.

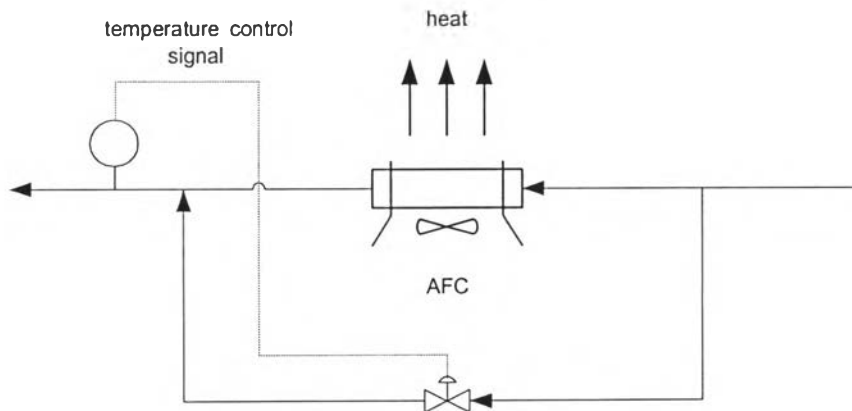

**Figure 4.7: AFC temperature control system**

- 9) *Loss of energy in steam let down system:* There are 2 steam systems used in process, low-pressure system and medium-pressure system. The medium-pressure steam (14.7 barg) is imported from steam supplier to drive steam turbines in the process and transfer to low-pressure steam (2.7 barg) to use in the process.

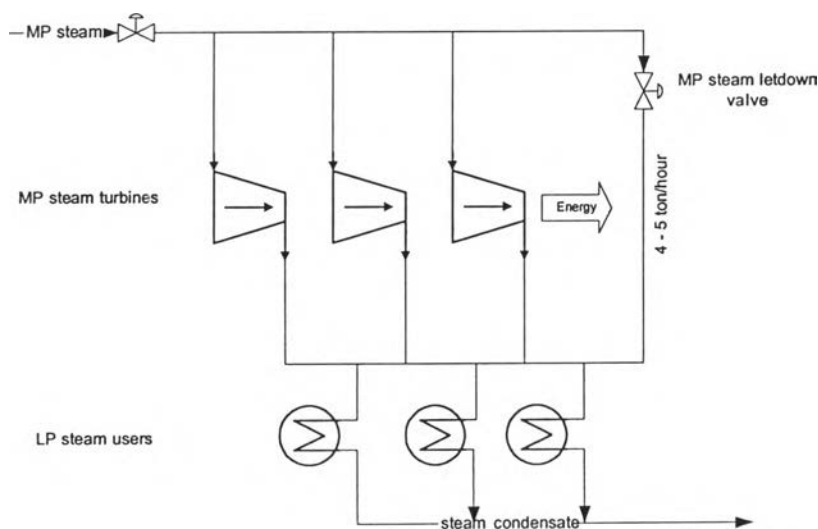

**Figure 4.8: Steam system diagram**

But in case of the consumption of low-pressure steam is more than the capacity of steam turbine to produce, the medium-pressure steam will be let down to low-pressure steam by passing the control valves that is the loss of energy because the energy from the pressure reduction can not be used.

10) *Loss of energy from lower temperature of rundown product:* In the process, AFC is also used to cool down the product rundown from the process before running to the storage tanks to avoid the tanks' boil over from the contaminated water in the tanks. From the present practice, many of rundown intermediate products are over cold down before running to storage tanks and reheated when they are sent to the next process unit that is the loss of energy.

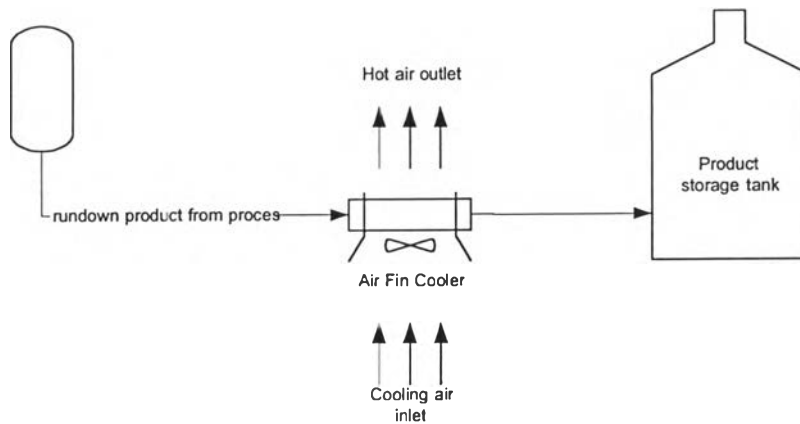

**Figure 4.9: The cooling system of rundown product**

#### 4.2 Potential failure modes and effects identification

From the result of the suggestion activity, the potential failure modes and effects are defined by cross-functional team as table 4.2.

**Table 4.2: Potential failure modes and effects**

<b>Process service function</b>	<b>Failure mode No.</b>	<b>Description</b>
<b>VDU heater</b>	<b>1</b>	VDU Heater's efficiency is low
<b>Hot oil heater</b>	<b>2</b>	HOU Heater's efficiency is low
<b>Sour Water Stripping</b>	<b>3</b>	Excess stripping steam
<b>Steam tracing line</b>	<b>4</b>	Failure of steam traps
<b>Dewaxing filter lighting</b>	<b>5</b>	One side of the dewaxing filters does not need lighting all the time.
<b>Bitumen blowing unit air compressors</b>	<b>6</b>	The compressed air from the compressor is excess and always blown to atmosphere.
<b>Instrument air compressor</b>	<b>7</b>	The compressed air from the compressor is excess and always blown to atmosphere.
<b>Cooling water system</b>	<b>8</b>	The temperature of cooling water supply is lower than designed value.
<b>AFC temperature control system</b>	<b>9</b>	The temperature outlet of AFC is controlled by using by-pass valve.
<b>MP/LP steam let down system</b>	<b>10</b>	MP steam is letdown to LP steam with the rate of 4 - 5 TPH constantly.
<b>Product rundown temperature</b>	<b>11</b>	Too low product run down temperature

### 4.3 Risk Priority Number (RPN) calculation

After the potential failure modes are defined, the severity of the effect, potential cause and detection method will be considered to calculate the risk priority number (RPN) by using the modified criteria. The calculated RPN is described in table 4.3. (See detail of calculation in Appendix I)



Table 4.3: RPN calculation

Failure Mode No.	Potential Effect (s) of Failure	S; e; v	Potential Cause(s) /Mechanism(s) of Failure	O c c	Detection Method	D e t	R. P. N.
1	Loss of fuel oil and steam for atomizing	6	Too high air flow rate (excess of combustion air).	7	% Excess Oxygen. (directly effect to the furnace's efficiency)	2	84
2	Loss steam for atomizing and fuel oil	9	Too high air flow rate (excess of combustion air).	10	% Excess Oxygen. (directly effect to the furnace's efficiency)	2	180
3	Loss of steam and increasing of amount of waste water	5	Steam used in stripping process is excess.	6	Sour water to steam ratio indicator.	3	90
4	Loss of steam	7	Corrosion or fouling in steam trap	5	Check steam trap working.	6	210
5	Loss of electricity.	4	There is no separation switch to separately turn on/off for the lighting of the filter.	10	Visual checking and current indicator of electricity used for the filters' lighting.	7	280
6	Loss of electricity:	6	The air compressor of each unit is designed at over capacity.	10	Air pressure control valve % output.	2	120
7	Loss of electricity:	3	The minimum current setting is too high. So, the minimum compressed air supply to process is more than requirement.	10	Air pressure control valve % output.	3	90
8	Loss of electricity.	5	The cooling fan's motor is fixed speed type, so, it can not reduce its speed although the water supply's temperature is lower than design value.	10	Cooling water supply's temperature indicator.	2	100

Table 4.3: RPN calculation (continue)

9	Loss of electricity.	4: The design is not optimization.	10 Measure the current consumed by AFC motor.	2	80
10	Loss of energy (both electricity and steam)	6: No existing steam turbine suitable to support this flow rate of let down steam.	10 % output of let down valve.	2	120
11	Loss of energy (both electricity and steam)	4: Too much cooling down rate of AFC.	10 Product rundown temperature indicator	2	80

From the RPN calculation, the potential failure modes that will be solved is prioritized as shown in table 4.4.

Table 4.4: The priority of potential failure modes to be solved

Failure mode No.	Description	RPN
5	One side of the dewaxing filters does not need lighting all the time.	280
4	Failure of steam traps	210
2	HOU Heater's efficiency is low	180
6	The compressed air from the compressor is excess and always blown to atmosphere.	120
10	MP steam is letdown to LP steam with the rate of 4 - 5 TPH constantly.	120
8	The temperature of cooling water supply is lower than designed value.	100
3	Excess stripping steam	90
7	The compressed air from the compressor is excess and always blown to atmosphere.	90
1	VDU Heater's efficiency is low	84
9	The temperature outlet of AFC is controlled by using by-pass valve.	80
11	Too low product run down temperature	80

#### 4.4 Action plan

In order to reduce RPN, the factors that are severity, occurrence and detection level of each potential failure mode are considered by the team to find out the most possible option to be done. In consideration, the ease of modification and effectiveness of the result are the important factors in decision making.

From the priority of RPN, the action plans to solve the failure modes are established as following.

##### ***Potential failure mode No. 5: Modify separation lighting switch at dewaxing filter***

In order to save the cost of electricity, the separation lighting switch should be modified to separately control the using of filters' lighting (See figure 4.10). Moreover, to modify separation switch can save the cost of bulbs because it reduces the unnecessary using of lighting that means the reduction of severity and occurrence level of the failure mode..

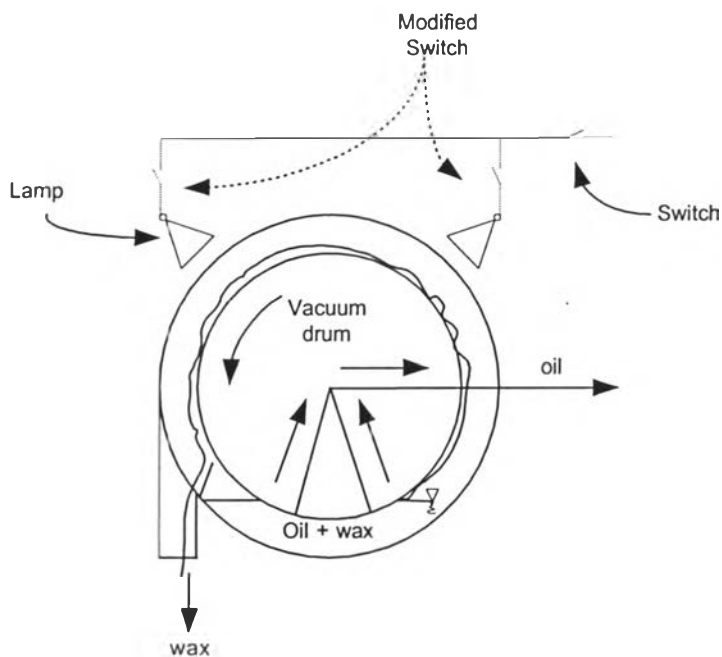

***Figure 4.10: Modification of dewaxing filter's lighting switch***

##### ***Potential failure mode No. 4: Set up steam trap inspection and repairing program***

In the plant, there are more than 2,000 steam traps used. The failure of steam traps causes the loss of lots of steam that can not be visual checked. In order to check the working of steam trap, there are two ways to consider; purchase the steam trap

inspection kids and contact the supply to do this job. In this case the company consider to contact the supplier because they do not want to invest the asset and the service cost of supplier is not so expensive. After the working of steam trap is inspected, the repairing plan must be set to repair the failed steam trap. Finally, the steam consumption and evaluation plan must be established in order to monitor the performance of the steam system continuously. With this action plan the severity and occurrence level can be reduced.

***Potential failure mode No. 2: Reduce excess  $O_2$  from hot oil furnace by modifying  $O_2$  controller***

The cause of excess Oxygen from the furnace is the combustion controller is not working properly. In order to use the combustion control system efficiently, the system must be modified to control the flow rate of inlet combustion air relatively with the percent of excess Oxygen from flue gas. With this modification, the percent of excess Oxygen can be set at optimum point by controlling the amount of inlet air's flow rate. With this modification, the occurrence level of the failure mode can be reduced.

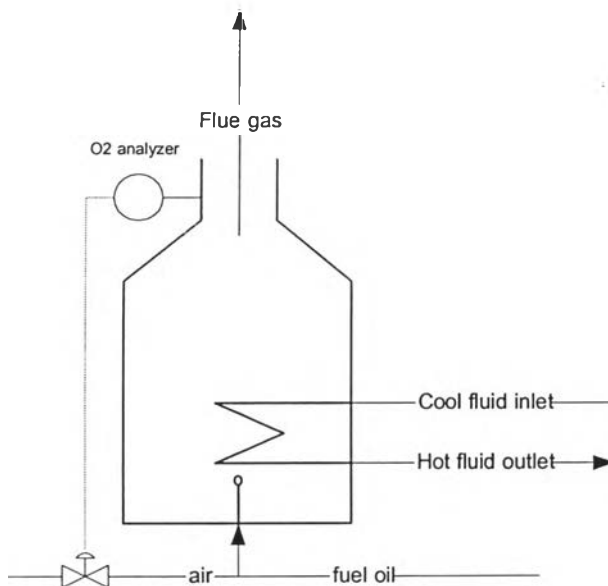

***Figure 4.11: Modification of  $O_2$  controller***

***Potential failure mode No. 6: Bitumen blowing units' common air line modification***

The capacity of one of bitumen blowing unit's air compressor can support both units in the same time in case of the units are running in low through put. So, if the outlet lines of the two air compressors are modified to be common line, one of air compressor can be stopped that can save the cost of electricity. With this modification, severity and occurrence level of the failure mode can be reduced effectively. (see figure 4.12)

***Potential failure mode No. 10: Modification of new steam turbine***

In order to avoid the let down of medium-pressure steam to low pressure-pressure steam, the new steam turbine that has the compatible capacity to support the medium-pressure steam let down flow rate should be installed. With the new steam turbine, the electricity used in the modified pump can be reduced because the energy from medium pressure steam will be used instead. (see figure 4.13)

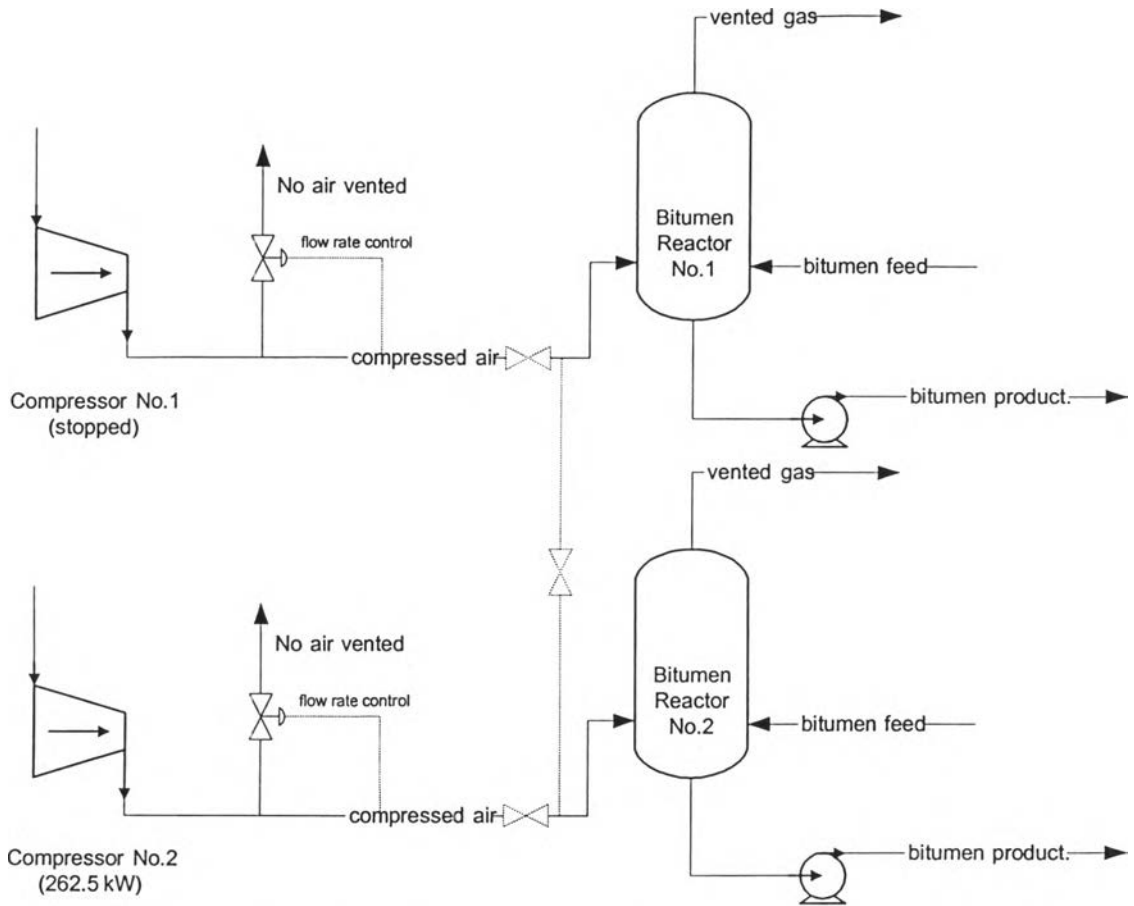

**Figure 4.12: Modification of bitumen units' air common line**

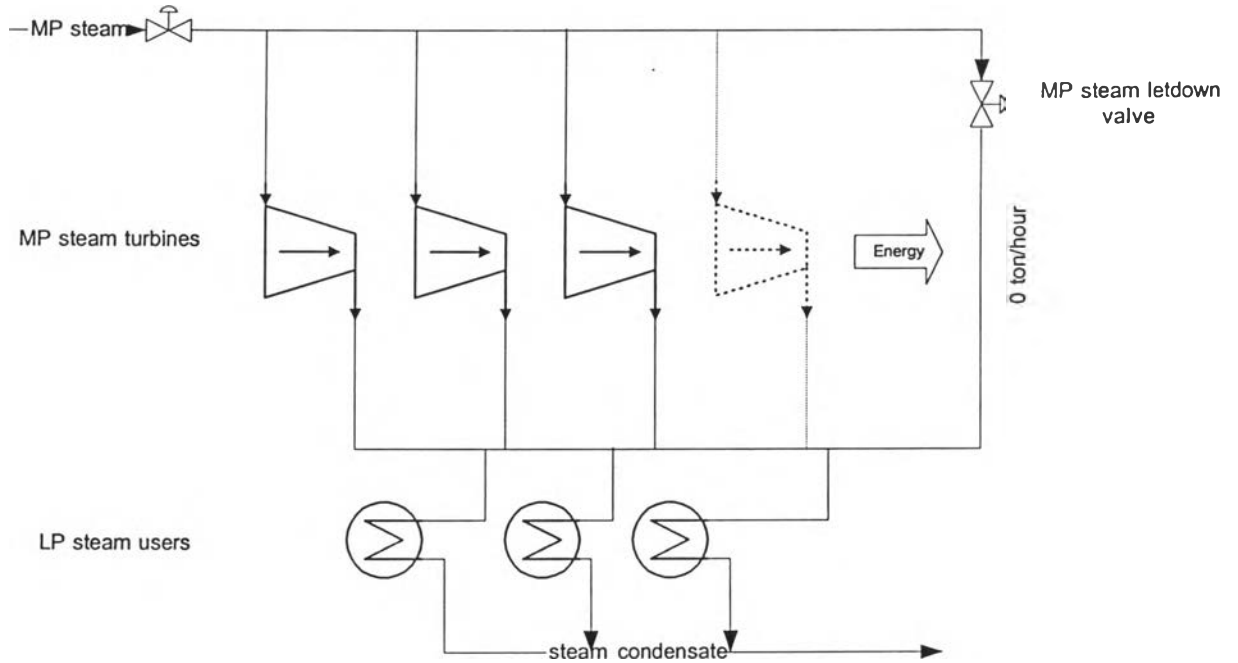

**Figure 4.13: Modification of new steam turbine**