



CHAPTER IV

EXPERIMENTAL EQUIPMENT DESIGN

This chapter is involving the design of mechanical and electrical parts of the experimental equipment.

4.1 Data collection for mechanical parts design

There are some mechanical parts of the experimental equipment that have to be designed, i.e. the nozzle, the compression cylinder etc. Before the mechanical parts can be designed, there are some pre-tests for confirmation of the surrounding process which could affect to the Foi-tong production. These are as follows:

4.1.1 *Viscosity Test*

The viscosity of Egg emulsion should have effect on the properties of foi-tong. The viscosity is a very important physical characteristic of fluid. It affects naturally directly to the flow of fluid. The higher the viscosity of the fluid is, the more difficult it can flow.

1 Mettler instrument

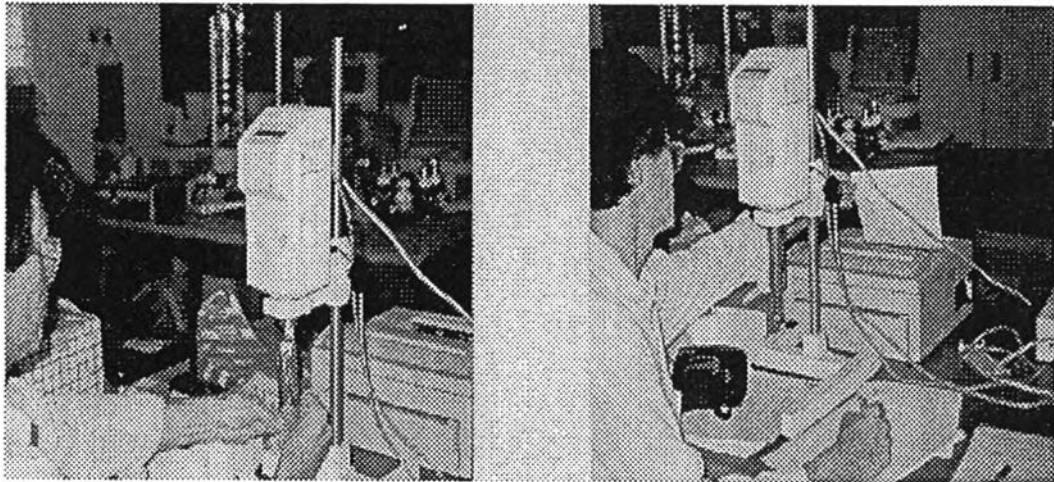

a) Viscosity test

b) Data printout

Figure. 4.1 Viscosity test for egg yolk.

----- RECORD OF MEASURED VALUES METTLER RM180 RHEOMAT -----

Table 4.1 Hen egg yolk 20% and duck egg yolk 80 %

DATE : 02.02.41
 SAMPLE No. : 2
 MEASURING SYSTEM: 33
 PROGRAM No. : 4

$$\frac{\tau[\text{Pa}]}{du/dy}$$

STEP TIME	TEMPERATURE [°C]	VISCOSITY [Pa*s]	SHEAR RATE [1/s]	τ [Pa]
1	:	TORQUE TOO LOW		
2	:	TORQUE TOO LOW		
3	26.2	0.160	373	51.7
4	26.1	0.156	557	79.1
5	26.1	0.152	741	101.
6	26.1	0.149	924	123.
7	26.0	0.147	1108	144.
8	26.0	0.143	1291	164
7	26.0	0.146	1108	
6	26.0	0.148	924	
5	26.0	0.151	741	
4	25.9	0.154	557	
3	25.9	0.157	373	
2	:	TORQUE TOO LOW		
1	:	TORQUE TOO LOW		

Table 4.2 Duck egg yolk 20 % and hen egg yolk 80 %

DATE : 02.02.41
 SAMPLE No. : 4
 MEASURING SYSTEM: 33
 PROGRAM No. : 4

$$\frac{\tau[\text{Pa}]}{du/dy}$$

STEP TIME	TEMPERATURE [°C]	VISCOSITY [Pa*s]	SHEAR RATE [1/s]	τ [Pa]
1	:	TORQUE TOO LOW		
2	26.8	0.372	190	42.3
3	27.3	0.234	373	79.3
4	27.3	0.215	557	114
5	27.2	0.204	741	145
6	27.1	0.193	924	175
7	27.0	0.187	1108	203
8	26.9	0.181	1291	230
7	26.9	0.184	1108	
6	26.8	0.187	924	207
5	26.7	0.191	741	
4	26.7	0.197	557	
3	26.6	0.204	373	
2	26.5	0.214	190	
1	:	TORQUE TOO LOW		

373	51.7
557	79.1
741	101
924	123
1108	144
1291	164

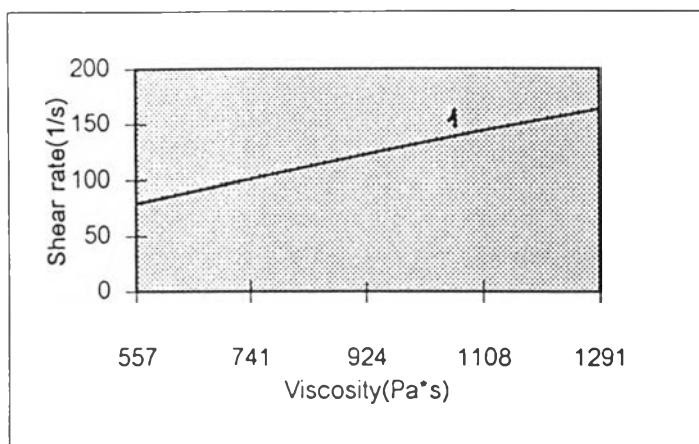

Figure 4.2 Hen egg yolk : duck egg yolk = 20 : 80 % (ref. Table 4.1)

190	42.3
373	79.3
557	114
741	145
924	175
1108	203
1291	230
1108	202

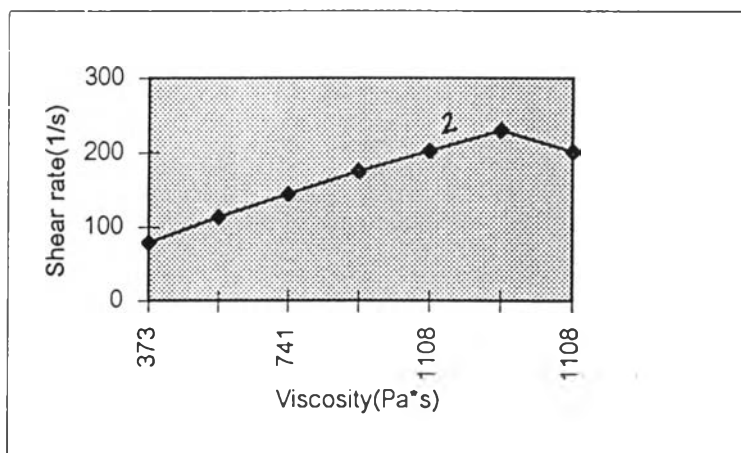

Figure 4.3 Duck egg yolk : hen egg yolk = 20 : 80 % [ref. Table 4.2]

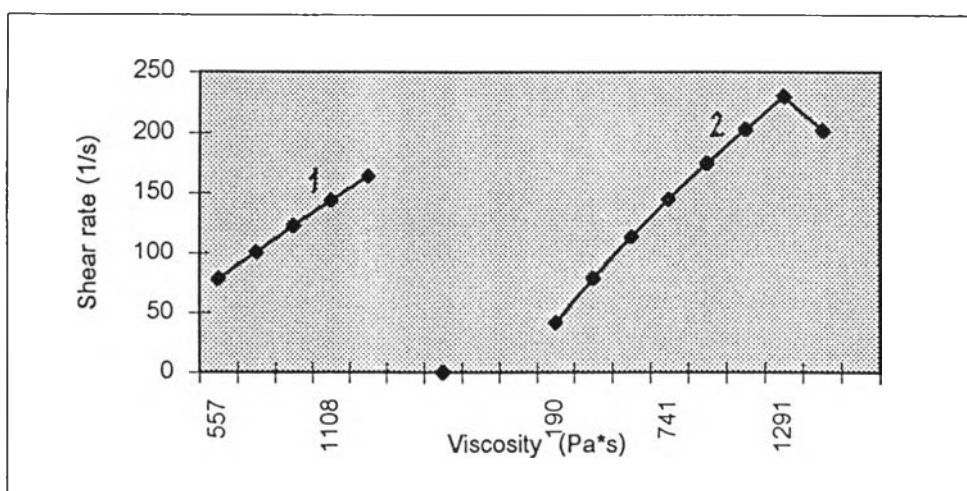

Figure 4.4 Comparison between Figure 4.2 and Figure 4.3

2 Result of viscosity test

Table 4.1 shows the viscosity of the egg emulsion (20:80% hen egg and duck egg yolk), Starting from 0.160 Pa*s and declining to 0.143 Pa*s. The graphical tendency is forming digressively into the region of pseudo-plastic in Figure 2.1 The egg emulsion viscosity is slightly decreasing while the shear rate [1/s] is increasing. The shear thinning is mild. Similarly, Table 4.2 of egg emulsion ratio 20:80 % duck egg yolk: hen egg yolk, starting from 0.372 Pa*s and declining to 0.181 Pa*s.

Thus, there is no exact data to estimate the egg elasticity and the shear thinning is also not so high. Here it can be assumed that the elasticity can be neglected. The nozzle design is described in Chapter IV , 4.3.4 , p.51

4.1.2 Friction test

The production of foi-tong by machine will be compared to the traditional string shape. In fact, production by the traditional way, using the banana leaves, brings a better quality shape than by machine.

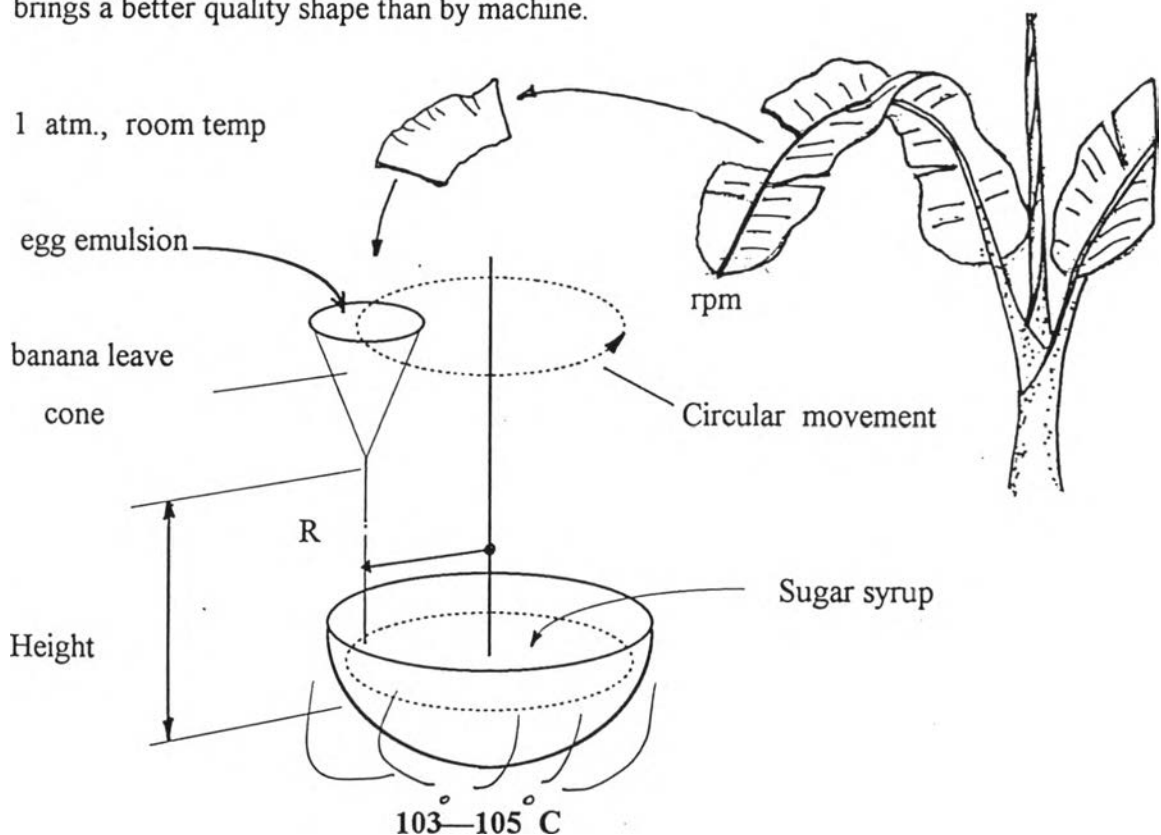

Figure 4.5 Diagram of traditional cooking of Foi-tong

1 Concept of test

To find out the specific friction coefficient of each material which would be applied for making the rilling cup. The test will be performed it task under the following condition :

1. Starting at room temperature
2. Working above 100°C vapor temperature of the boiling syrup (water vapor) in open air , normal atmosphere
3. Egg-emulsion mixture 80:20 of duck : hen eggs.

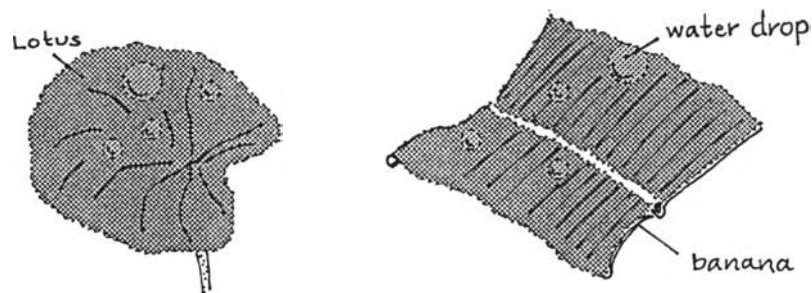

Figure 4.6 Smooth thin film on banana leave and lotus leave

2 Set-up of the test equipment

Material Selection for test

- Steel sheet 2 mm thick plastic sheet grade PE
- Stain less steel 2 mm thick banana leave
- Brass sheet 2 mm. Thick

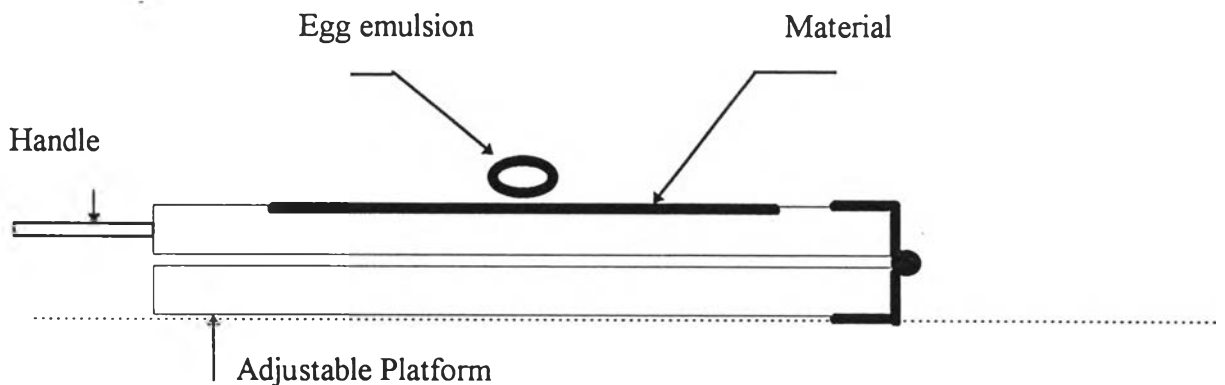

Figure 4.7 Set up of equipment set for friction test in normal atmosphere

3 Test procedure

- boil some water underneath the platform
- drop 1 drop of egg emulsion (duck : hen = 80:20)on the material surface
- lift up the handle of the moving plate slowly until the egg emulsion start moving downwards
- observe the inclined angle ρ , The value of $\tan \rho \approx$ friction coefficient μ

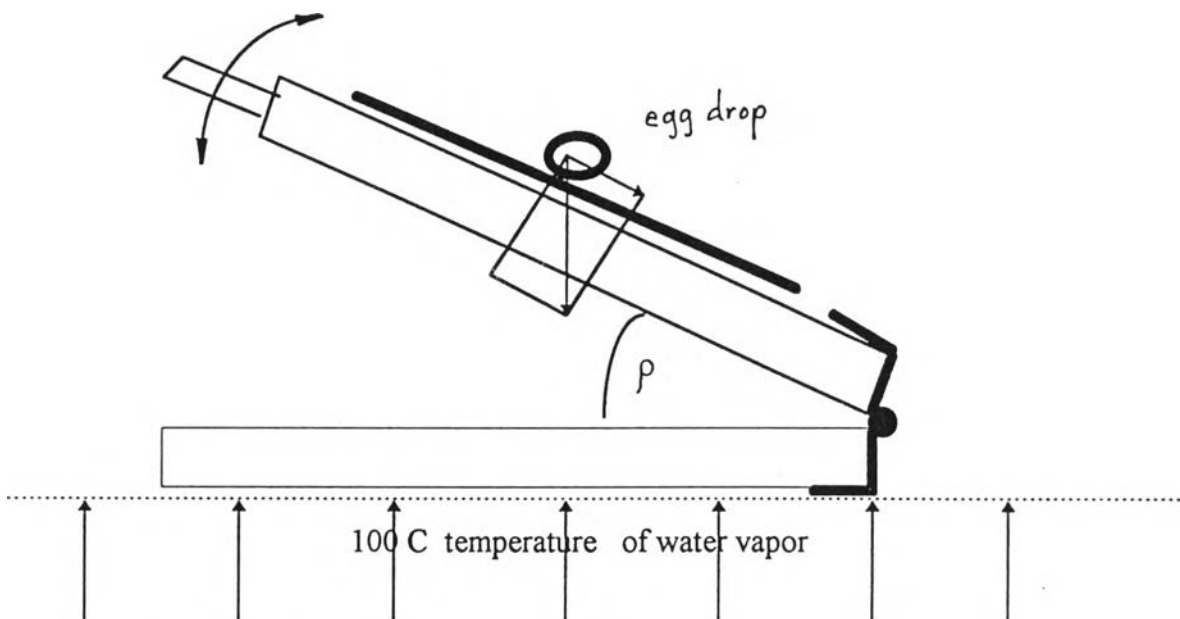

Figure 4.8 Friction test of egg emulsion

4 The Result

Material	inclined angle ρ	$\tan \rho$	$\approx \mu$
• Steel sheet 2 mm thick	41	0.869	0.869
• Stain less steel 2 mm thick	35	0.700	0.700**
• Brass sheet 2 mm. Thick	38	0.782	0.782
• Plastic sheet grade PE	29	0.554	0.554*

Table 4.3 Friction test result

The friction test result indicates that the least friction coefficient is $\mu \approx 0.554$. The next coefficient is $\mu \approx 0.700$. Plastic PE-Food grade is the best material but it is very costly. Stainless steel and PE are selected for a nozzle design. To design the nozzle from the combination of two material : stainless steel is appropriate for food processing utensils, PE is appropriate for a nozzle. For designing of the rilling cup of experiment equipment can be selected the stainless steel for the cup and the PE Food grade for the rilling nozzle. More details will be discussed in 4.3.4

4.1.3 compression test

- Primitive Design of the Rilling Cup

The rilling cup made from stainless steel. There are several kind of a rilling design.

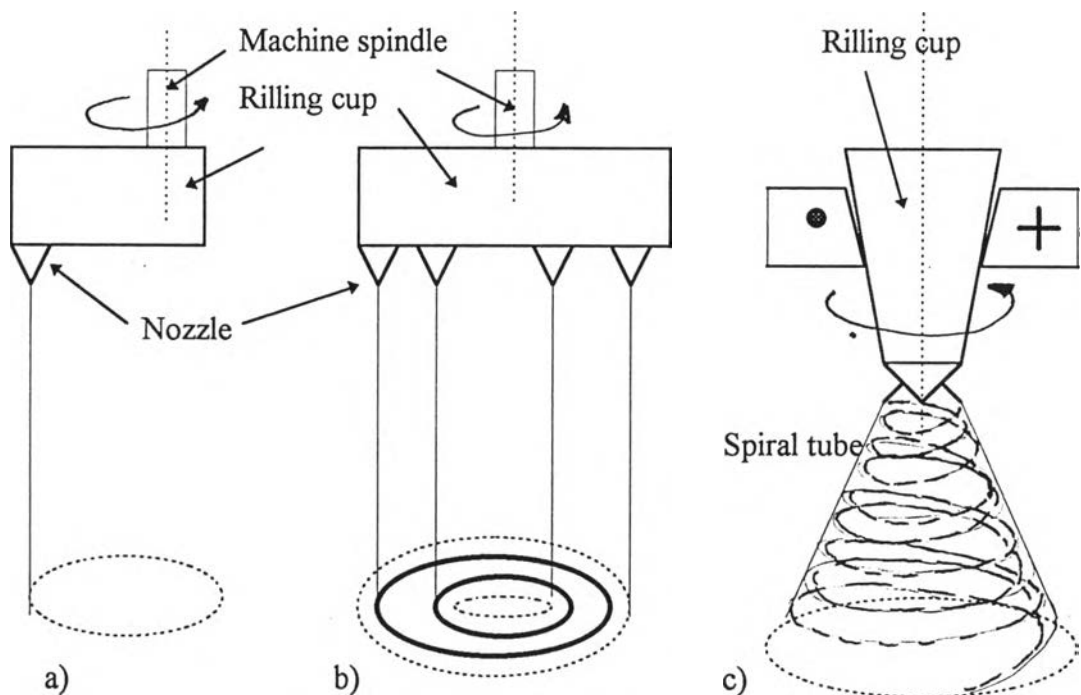

Figure 4.9 Design of rilling cup

- a) a single straight hole
- b) multiple hole
- d) spiral (hollow) tube

Normally the egg emulsion flows through the nozzle in a round shape. But afterwards, during the string interpretation through the air above the cooking pan, the egg string starts getting problem of maintaining its initial shape as it was formed by the nozzle.

1 Hypothesis of test

- There are some factors that cause this appearance such as :
 1. The centrifugal force in the rilling cup.
 2. The reaction force from the surrounding such as the wind etc.
 3. The capillarity attraction occurs in the nozzle hole. This is an opportunity to let air to penetrate into the egg-emulsion string

- Analysis

The centrifugal force occurrence under an inappropriate revolution of the rilling cup. The mass momentum of the egg emulsion is encouraged by its weight including the centrifugal force which is increasing in direct proportion to the revolution per minute of the driving spindle.

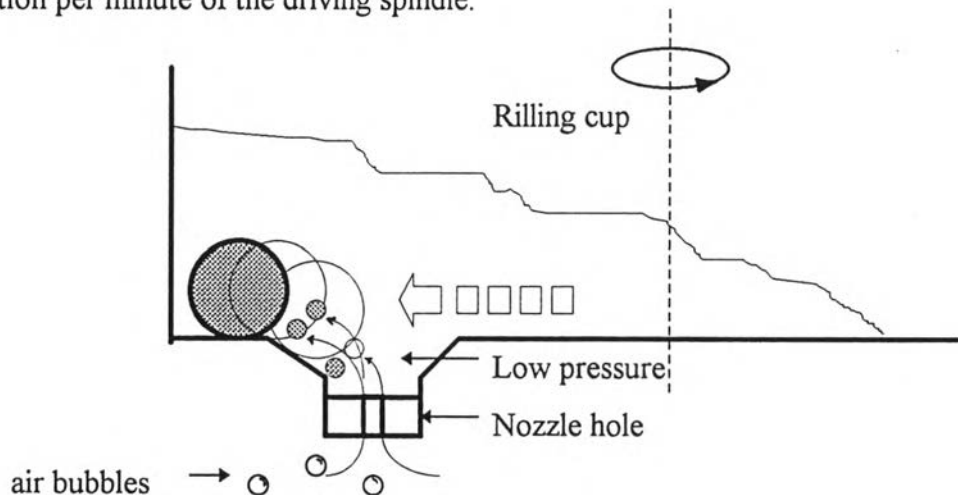

Figure 4.10 Internal effect caused by the mass momentum passing the opening and produce a low pressure (vacuum) zone.

The force directions of the mass momentum and the centrifugal force add together and point to the cylinder wall. While the egg emulsion pass the upper end of the nozzle, with a big amount of egg emulsion will pull the liquid in the excavation

The consequence of this is the low pressure zone , some egg emulsion will come up from the hole as well as some air bubble. Beside this , the external effect causes be surroundings such as the wind and centrifugal force push the egg-emulsion string. This can also affect the string shape.

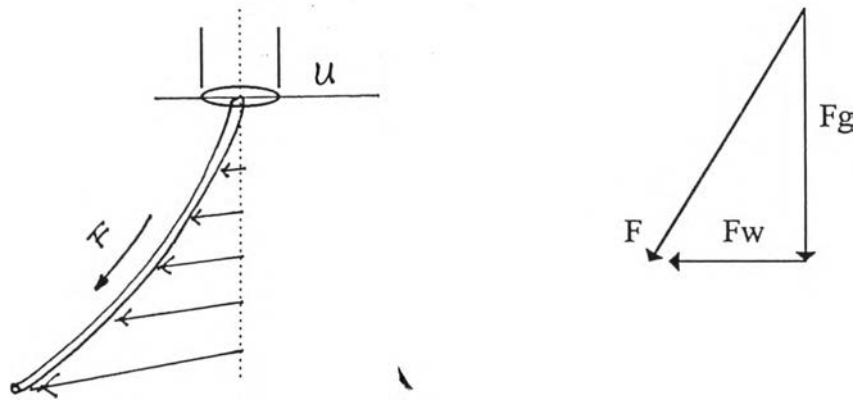

Figure 4.11 The external effect causes by surroundings and consequence to the shape configuration of foie-tong string.

2 Concept of Experiment

To maintain the internal force of the egg emulsion which is caused by its mass and the gravity is not enough to overcome the occurrence of the vacuum due to the mass momentum of the egg fluid in the rilling cup. One of the concept to resist this phenomena is the position of the nozzle should designed at the position where the direction of the mass momentum is intending. The centrifugal force will press the fluid through the hole opening resisting the out side air bubbles which try to penetrate into the rilling cup.

On the other hand , to overcome the penetration of the air bubbles it could be applied a compressive force. This experiment involves the test of a compression bag (for cake cooking) filled with egg emulsion. The compression bag (in stead of the banana leave cone) is pressed and swung by hand around the circular pan at a certain height.

3 Set up of test equipment

The preparation is the same as the primitive production method . The different is in use of the compression bag instead of the banana leave cone .

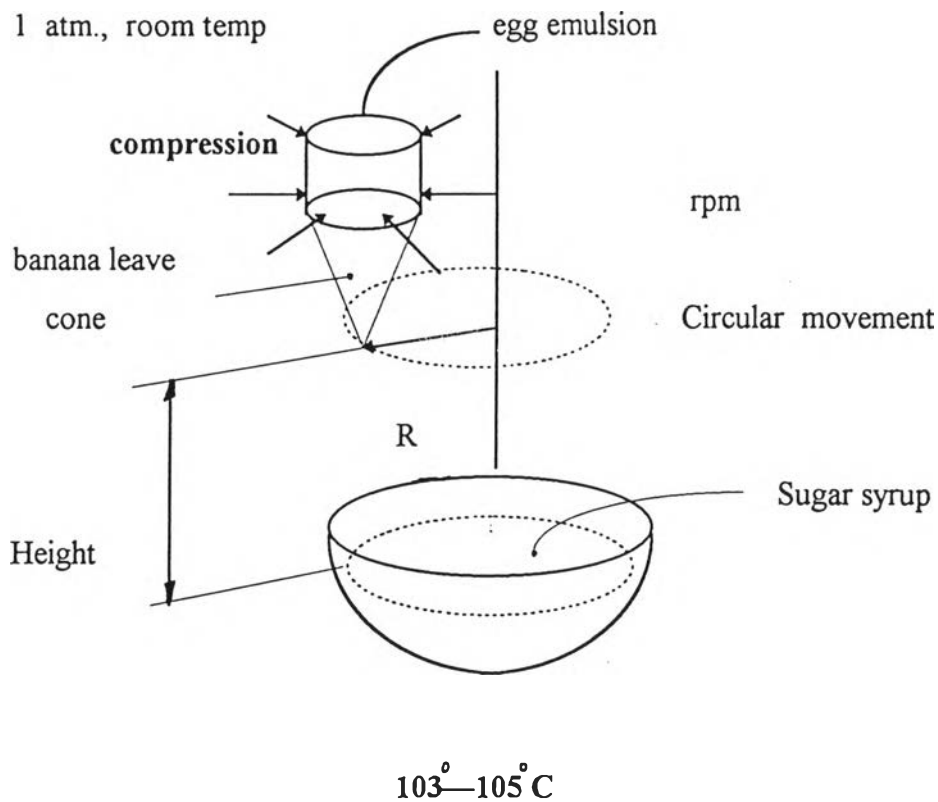

Figure 4.12 Set-up of equipment set for compression

4 Test Procedure

- boil the syrup in a circular brass pan
- wait until the syrup get the temperature of 105°C
- pour the egg emulsion (80:20 of duck : hen) into the compression bag and close the bag carefully
- When the syrup is boiling ,maintain the certain height -rilling height - above the pan
- press the bag by hand nicely as well as swing around the pan .
- be careful the application of hand force must be consistent.

5 Test Result

The data collected from the test are many samples of foi-tong string. During the rilling test procedure the data of height(h), rilling speed (s) and compressive force (p) are observed and collected approximately as follow:

The data which have to be gathered here are approximately :			
The rilling height	of	100	to 150 mm.
The rotation speed	of	50	to 90 rpm.
The compressive force of		5.8	to 17.67 N
The nozzle hole is constant		1.	mm. (assumption)

The test result shows the appropriate tendency of the cooking conditions, operational control factors. The exact values of them have to be investigated again.

4.1.4 Conclusion

The results of viscosity test, friction test and compression test can be concluded below:

Viscosity test : Egg emulsion has its tendency in the region of pseudo-plastic, but not so strong. Its shear thinning is slightly higher than water. Its elasticity is therefore difficult to be defined. Even though, in order to optimize the fluid flow through a small hole, an appropriated shape design of a nozzle has to be considered and selected.

Friction test: This test is performed with the approximation. The result can help designer to select an appropriate material good for egg emulsion. Observing the vapor temperature can heat sheet metal and the heat can be transferred to the egg drop. This can raise the friction angle of the platform because the egg drop start being well-done and stuck at the position. Therefore, to select a material, the friction angle at room temperature and the heat coefficient of the material should be considered it

For the case of a rilling cup. The stainless steel should be suitable for making the cup and PE for its nozzle.

4.2 Data collection for electrical parts design

To control some factors which can affect the cooking process, some small electrical devices have to be available. Some devices or equipment can be found on the market, some of them are very costly. For this research, the electrical controller for stabilizing the syrup concentration would be essential. These following 3 tests are involved in electrical part design. These following pretest result can confirm and support creative idea for designing an electronic circuit to control the concentration of the syrup, to control its level in the cooking pan and to control the cooking temperature:

4.2.1 Syrup resistance test

In general , to control liquid level, it can be easily done by using a level controller such as a float switch. In the case of boiling liquid like sugar syrup , the certain level would be disturbed by air bubbles . The sensor of a float switch would the wrong level response. The other problem is the environmental problem. The boiling water can lose its initial quantity and property, the sweetness of sugar syrup increase. one of the main factor affecting shape configuration of Foi-tong string.

By Pre-test string has support that the Foi-tong string can configurate in different kind of shapes. However, it does not means that the more concentration of the boiling syrup, The more radian spread-out the string can be. hot doesn't means that the more concentration the syrup has , the better or more favored the Foi-tong will be. The best favor, sweetness of Foi-Tong is a fixed factor at around 60% concentration (Chauchamnan , 1990.) Therefore, the concentration for fluid resistance test should be maintain at **60:40 of the sugar : water** mixture.

There are many kinds of instrument to control both sugar concentration and syrup level , such as many types of floating switch , diaphragm detector , pressure detection, even back pressure type can be selected . But , the cost of these instrument are very

high and to check the concentration by fluid resistance might be very complicated system and may not be available in Thai instrument market (Sangchaimeter , 1998). This pre-test is therefore involved with the investigation of fluid resistance which can be possible to support an electrical control circuit. And, in combination of using a normal floating switch.

1 Objective of this experiment

1. To investigate the fluid resistance behavior while the electrical current pass through it. The collect data hereby will be in ohm.(k Ω)
2. To design an electrical circuit used to control the level and concentration of the syrup in a cooking pan.

2 Hypothesis

While an electrical direct current passes through any fluid (electrolyze), the resistance which can be measured by an ohm's meter should be fluctuated upon the concentration of the fluid ,in this case , the concentration of the sugar syrup.

3 Experiment Concept.

Using two platinum rods with diameter of 2 mm. and 150 mm. long as electrode "a" and "b" . The platinum is heat resistant and has good physical character in electrical application. By preparing a simple fixture for them to insert through two holes with a center distance of 5 mm. and 40 mm. At first , these two rods will be fixed at a distance of 5 mm. After that , connect the upper ends with + and - of an ohm's meter. The other two lower free-ends will be sunk in syrup with 60% of concentration. During heating the syrup its resistance of it will change exponentially depending upon the temperature of the syrup.

4 Tool and test equipment

1. 5 pieces of a 300 cm³ test beaker
2. Multimeter with probes.

4. A 0 - 250 °C Thermometer
5. At least 1 kw. Electric stove.

5 Syrup Preparation

The syrup contains sugar and water. There are five different mixtures as stated in the Table 4.4 mixtures

No	1	2	3	4	5	Unit
Water	50	45	40	35	30	gm
Sugar	50	55	60	65	70	gm
Concentration	50	55	60	65	70	%

Table 4.4 Preparation of the syrup ingredient

6 Experiment Steps

1. *Cold Electrolite (drink-water 20 °C)*
 - Set multimeter to the position of ohmmeter by selecting a measuring range of X1 K Ω

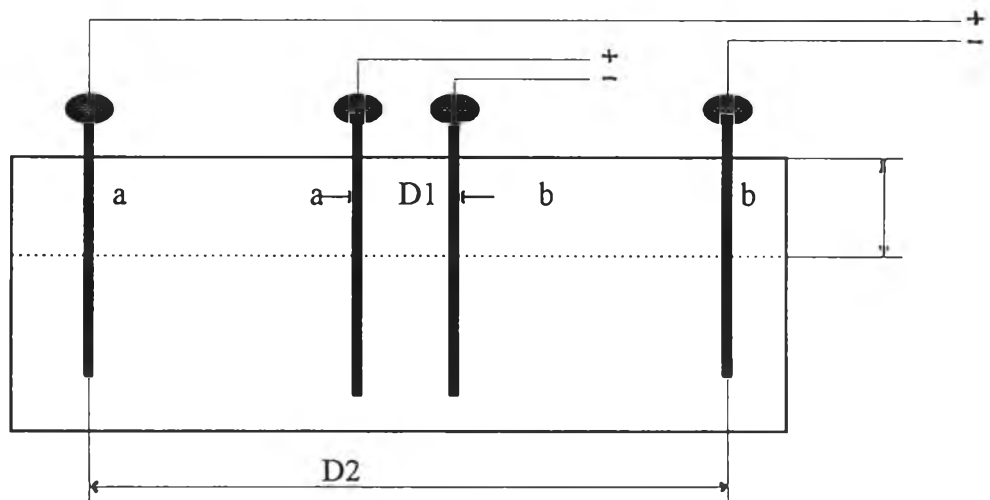

Figure 4.13 Experiment set up

- Immerse the probes of multimeter into the 300 cc water beaker by means of the probe a and b sunk at the same level. To read the resistance report $10\text{ k}\Omega$
- Resistance measuring of the water between two probes (distant of $d_1 = 0.5\text{ cm}$, $d_2 = 4\text{ cm}$) as shown in figure bellow.

2. Hot electrolyze (100 °C water)

3. Syrup electrolyze

The concentration syrup of 50% , 55% , 60% , 65% , and 70% respectively are tested by following the experimental

7 Experiment Result

Electrolyte distance	cold water 20 °C	hot water 100 °C	syrup concentration				
			50%	55%	60%	65%	70%
0.5 cm	12	9	9.3	9.8	10	12	14
4 cm	10	7	12.5	13	16	18	24

Table 4.5 Experiment Result

8 Experiment conclusion

According to the experiment result it can be concluded that the electrical current passing into an unstable mixture of a fluid like syrup with different concentration and temperature. The resistant in $\text{k}\Omega$ will decrease while the

temperature of water increase. And the resistant in $k\Omega$ will increase with increasing concentration of the syrup.

The benefit of this experiment is the fluid resistant characteristic which can support the design of a electrical controller for controlling the syrup concentration. And by variation of the resister , the syrup concentration can also be regulated as required.

4.2.2 Level control test

The syrup level can sink during the cooking process. Because some water escape in the form of vapor. This causes the fluctuation of syrup level as well as its concentration . There fore, the maintaining of the concentration doesn't required only electronic circuit but also a level controller. They have a co-function: the level controller acting as ON/OFF switch, electrical bridge for starting the concentration controller. The concentration controller will select and start the reserve pumps.

4.2.3 Temperature effect

Control of temperature of the cooking process is possible by using a temperature controller and thermocouple. The temperature controller can be set as required. Temperature controller and thermocouple can be bought in the marker. The required temperature range is $0-300^{\circ}\text{C}$ in Figure 4.20 at D

Conclusion

A level controller will be prepared by hand , its function is similar to a float switch, simpler design of level controller will be discussed in detail in Chapter IV For temperature control design will be also discussed in the Chapter IV , p.62

4.3 Circular motion equipment - Compression Tube -

A compression tube is a tube which will be containing the egg emulsion for cooking Foi-tong. . The different from the traditional method of cooking is that the use of the compression tube must be applied a compressive force . This compression will force the egg emulsion in the tube in order to resist the air bubble and to maintain the initial shape of string through the nozzle holes.

4.3.1 conceptual design

Apply a spring force to pull the piston rod (backwards) in order to press the piston in side the cylinder . In side the cylinder , the piston will force the egg emulsion through a nozzle hole

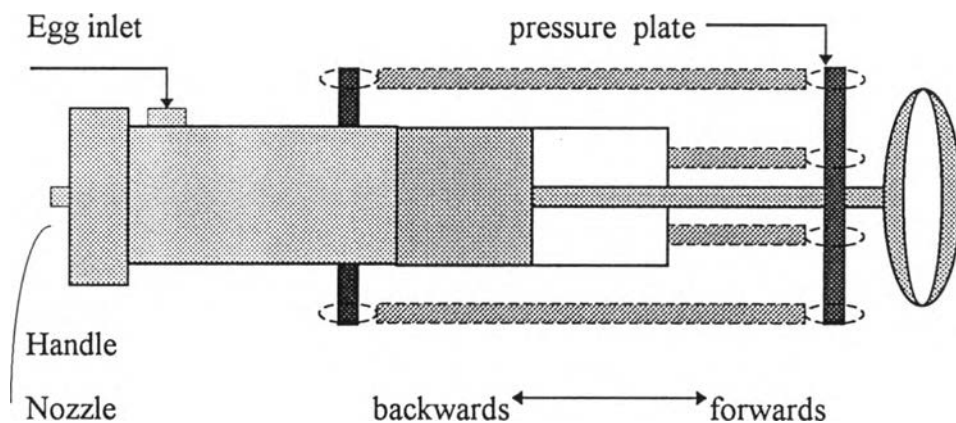

Figure 4.14 Conceptual design for compression tube

4.3.2 Working principle

The handle will be pulled out to the right hand side as the suction action of the piston in side the cylinder. The egg emulsion from the container will be sucked into the cylinder through the inlet hole. By loosing of the handle ,the springs which are clinging at the pressure plate will pull the piston rod backwards. The piston will compress the egg emulsion through the nozzle hole.

4.3.3 Compression force

The force which can cause the enhancement of the internal pressure inside the closed tube contained with egg emulsion has to be an *indirect compression*. For the test tube prepared only for the pre-test, a pneumatic system could be applied but the use of it would be rather more complicate than a spring application.

4.3.3.1 *Calculation of spring force and its displacement*

It is necessary to define the pressure which are pulling the piston rod end to press the egg emulsion through out the nozzle. The following data will be prepared for the experimentation

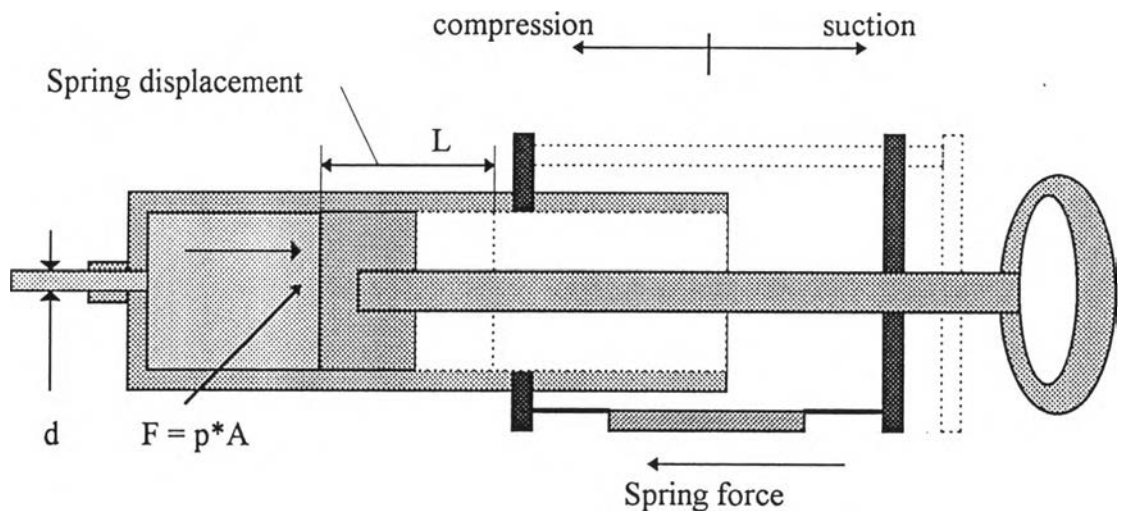

Figure 4.15 Calculation of spring force and its displacement

Spring rate	$C = F / L$	N./cm.
Where, Compression force	$F = \frac{\pi D^2 p}{4}$	N.
Displacement	$L = F / C$	cm.
Thus, Spring force	$F = C * L = \frac{\pi D^2 p}{4}$	N.

Selected a standard tension spring with spring rate of 10N / 7 cm.

$$C = 10 / 7 = 1.44 \text{ N/cm.}$$

The compression tube is designed for 8 tension springs to pull the piston-rod end and perform a pressure to the egg emulsion.

4.3.3.2 *Spring in combination* (Harold A. Rothbart,1986)The compression tube needs springs in combination . It is designed for eight tension springs around the tube . The combination is parallel combined :

$$\text{Spring force } P_{12345678} = P_1+P_2+P_3+P_4+P_5+P_6+P_7+P_8$$

$$\text{Linear deflection } \delta_{12345678} = \delta_1+\delta_2+\delta_3+\delta_4+\delta_5+\delta_6+\delta_7+\delta_8$$

$$\text{Rate } \kappa_{12345678} = \kappa_1+\kappa_2+\kappa_3+\kappa_4+\kappa_5+\kappa_6+\kappa_7+\kappa_8$$

Therefore, the sum of the spring rate :

$$\Sigma C = C_1+C_2+C_3+C_4+C_5+C_6+C_7+C_8 = 8 * 1.44$$

N/cm.

Substitute in.....

$$L = \frac{[\pi * 5 * 5] p}{4 * 11.52} \quad \text{cm.}$$

$$L = 1.70 p \quad \text{cm.}$$

$$\text{Hereby, } [p] = 1 \text{ [N / cm}^2\text{]} = 1[\text{bar}]$$

$$p = 10 \text{ N/cm}^2 = 1[\text{bar}]$$

$$\text{Thus, } L = 17.0 * p \quad \text{cm.}$$

$$\text{Notation : } L = 17 p \text{ , } [L] = [\text{cm.}]$$

4.3.4 Nozzle Design

According to the result of the friction test in Chapter III, the viscosity tendency of the egg emulsion is decreasing slowly with an increasing shear rate. The emulsion is not so different from the normal Newtonian fluid. The elastic property of the egg emulsion can not easily be defined because there is no exact data to estimate the elasticity of egg. However, the nozzle can be designed by observation the experiment result of the flow behavior. The shape of the nozzle can be selected by comparing its shape with the primitive banana cone (approximately 30° cone angle).

4.3.4.1 Vortex occurrence by nozzle design

There are many phenomena leading vortex formation in fluid flow. **D.V. Voger and K. Watters, 1993** edited many thesis results involving the experiments for investigation on the phenomena of non-Newtonian fluid flows through pipes and nozzles. Due to the fluid friction, i.e. viscosity, against the inside wall of the pipe or nozzle, this causes an obstacle called Vortex formation around a non- appropriately designed shape.

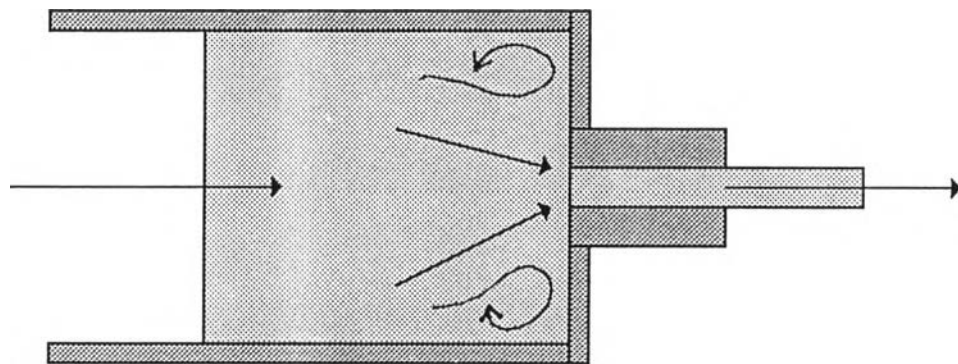

Figure 4.16 Occurrence of a secondary vortex flow

By the reduction in pipe size meaning a piping with different pipe sizes, the vortex occurs in different ways, depending on the flow rate and the property of the fluid. In the book edited by **D.V. Borger and K. Watter, 1993**, page 36, it is shown that elasticity makes the vortex bigger and sometimes the flow unstable.

4.3.4.2 Selection of nozzle shape

Nozzle design for a single rilling hole

- a) based on a primitive banana-leave cone with 30° , 1 mm. diameter.
- b) inside shape of the nozzle
- c) fluid phenomena of a nozzle designed with a sharp corners
- d) the avoidance of vortex occurrence by assuming a smooth curve throughout the rilling hole.

Observation : An egg emulsion is a slightly non-Newtonian fluid. When its water content is lost its viscosity increases. and therefore, the elasticity is considered also to increase (see viscosity test).

Shape design:

a design of the nozzle is therefore a bit difficult. But the nozzle can be designed by observing the experiment results of the flow behavior. There is no egg liquid result. However it can be compared both to the test result and comparing to the initial shape of the primitive banana leave cone approximately 30° cone angle.

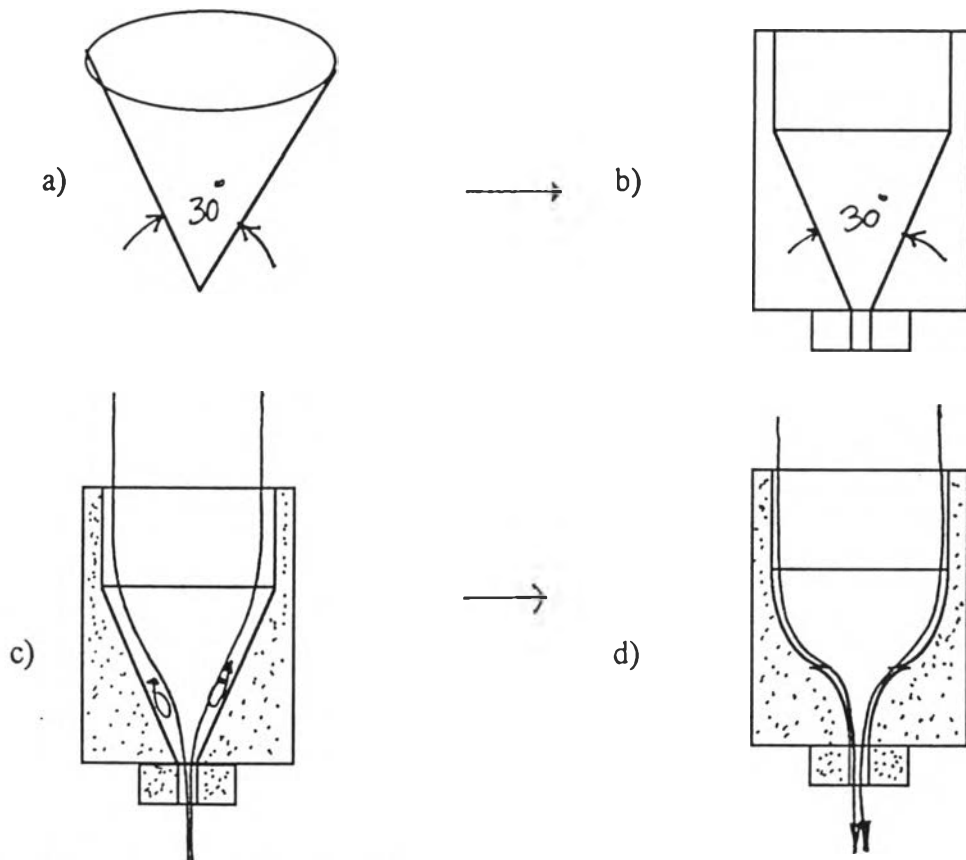

Figure 4.17 Selection of nozzle shape

4.3.4.3 Design and calculation

Inside the rilling tube (new design) of testing apparatus as sketched in Figure 4.17 d) . There are some phenomena of the egg emulsion flow and its pressure while the tube is rotating. They can be defined by calculation as follows:

The velocity leaving the nozzle. By observation the primitive Foi-tong production. The volume rate in banana-leave cone is to be studied.

By filling the volume of egg emulsion in a banana cone $d = 50$ mm. $h = 60$ mm., through hole 1 mm.

$$Q = \frac{1}{3} * 3.14 * 50^2 / 4 \text{ mm}^3 \\ = 39.27 \text{ cm}^3$$

and rill all of this volume into a boiling syrup with height of 100 mm. above the syrup surface. It is showed that Q is 39.27 cm³ an leave the hole in 147 seconds.

By apply

$$Q = A \bar{V} = 39.27 \text{ cm}^3$$

$$\bar{V} = Q/A$$

Then, $\bar{V} = 34.02 \text{ cm/s}$

Critical velocity

The observation result is a primitive production process, but it is still effective. Only the quantity of Foi-tong is still too low. In order to increase the amount of the product some factors have to be modified. This thesis involves the enhancement of the product quantity as well as maintaining of the string shape.

Referring to Reynolds Number in Chapter II

D, \bar{V} , of the egg emulsion can be modified, but the product of the group must not excess the critical Reynolds Number of 2100. This is because the transition region between laminar and turbulent flow:

Thus :

$$N_{re} < 2100$$

For the case of egg emulsion is selected between 700...1000

Assumption :

D = diameter of the nozzle const. = 1 mm
 = density of egg emulsion const. = 4.2 kg / dm³
 = viscosity of egg emulsion const. = 0.2266 Ps
 = can be varied in this case

$$N_{re} = \frac{1 \times \bar{v} \times 4.2 \times 1000}{1000 \times 0.2266} \quad \frac{m \times Kg \times m \times N \times s}{N \times m \times s \times m}$$

$$N_{re} = 18.53 \times \bar{v}$$

Selected $N_{re} < 2100$, $N_{re} = 700 \dots 1000$

V	N(Re)
10	185.3
20	390.6
30	555.9
40	741.2
50	926.5
60	1111.8
70	1297.1
80	1502.4
90	1667.7

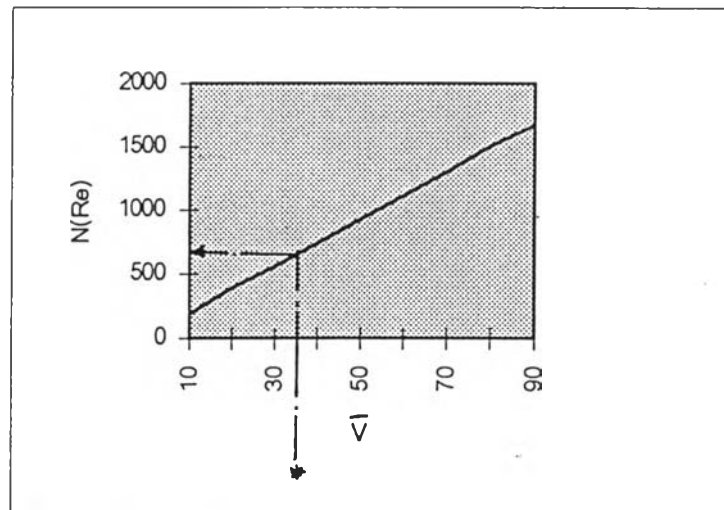

* traditional \bar{v} , N_{re}

Fig. 4.18 Relationship of Reynold number and average fluid velocity of egg emulsion

4.4 Linear motion equipment

4.4.1 Design of Electric Stove

4.4.1.1 Concept of the stove design

The electrical stove is to be designed . The temperature is to be controlled by a thermocouple and a temperature controller (0° — 300° C). The different ranges of temperature can be selected depend upon the test purpose. Here the temperature is to be control at 103° C

4.4.1.2 Assembly drawing

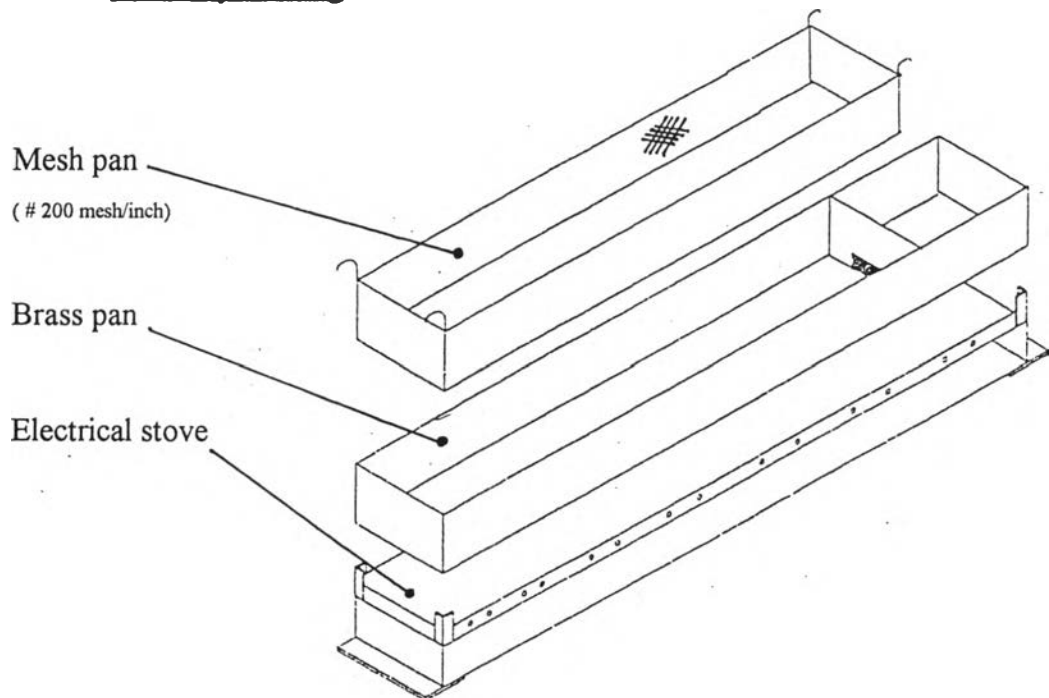

Figure 4.19 Design of electrical stove

4.4.1.3 Material selection

1 Stove stand (made)

- Stainless steel sheet 0.9 mm.
- Hot plate (steel) with six grooves for straight heater

2 Brass Pan (made)

- Rectangular brass pan volume = 24 Liters made by brass sheet 2 mm thick, fold and soldering.

- Rectangular brass pan volume = 24 Liters made by brass sheet 2 mm thick, fold and soldering.
- section for Sensors a partition sheet with 100 through holes of 3 mm. mesh diameter =100 holes /inch

4.4.1.4 Heating element(bought)

- Straight heater
- Temperature Controller. PID controller, Digital display both setting temp and actual temp. Selected : VCR - 130 R/E 0 - 400 C
- Thermocouple (Temperature sensor) Selected: JB10 size: 610mm.
- Magnetic contractor: selected 40 Amp. 220 VAC

Note : setting-up of electric stove showed in Figure D17-D18, Appendix D

4.4.1.5. Wiring Diagram for Electric Stove

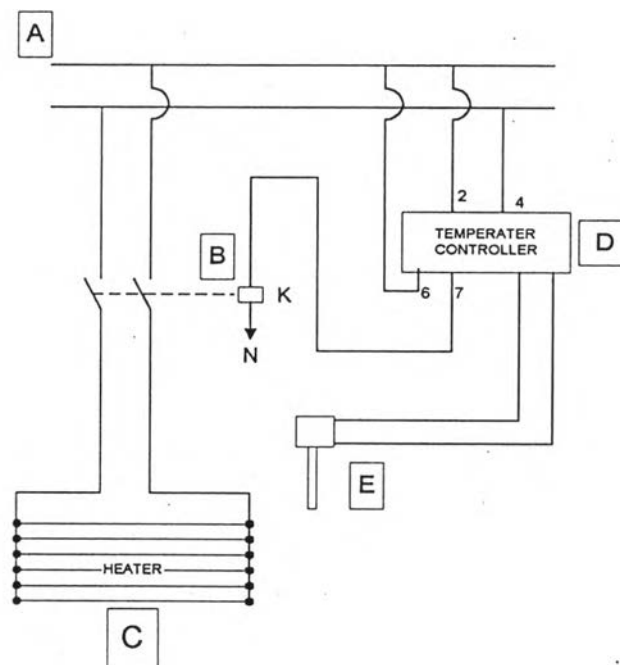

Figure 4.20 Electrical wiring diagram for electric stove

Note : setting-up electrical wiring showed in Figure D22-D23 , Appendix D

4.4.1.6 Unit Description

Unit A: Main breaker ; 63 Amp, 220 VAC, electrical supply to selected is L1 and N

Unit B: Magnetic Contractor K 40 Amp L1 and Output L2

Unit C: Electric heater

There are six pieces of linear heater (1 meter long each) and the sum of heat quantity 6 kW of R1---R6 parallel connection and two main lines are connected to T1 and T2 of the magnetic Unit B

Unit D: Temperature controller

Power in at node 6

Power out at node 7

Power in at node 2

Power out at node 1

Thermocouple connected to node 21,22

4.4.2. Design of rilling cup (new design)

4.4.2.1 Assembly drawing and material specification

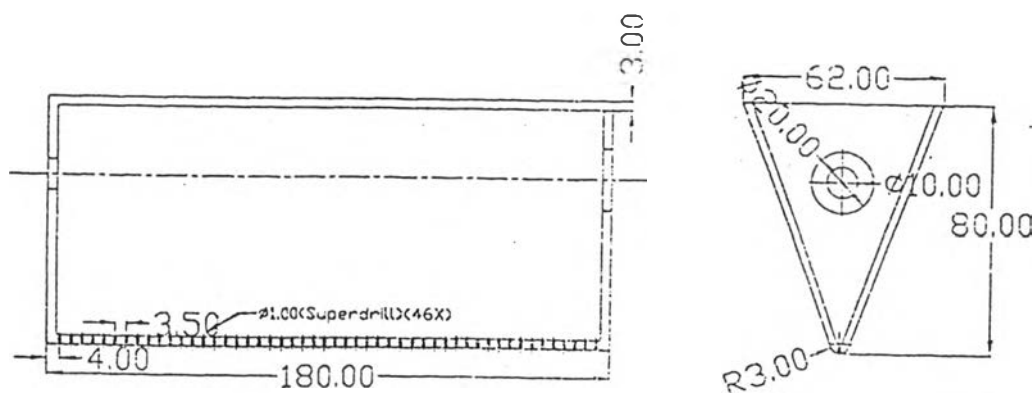
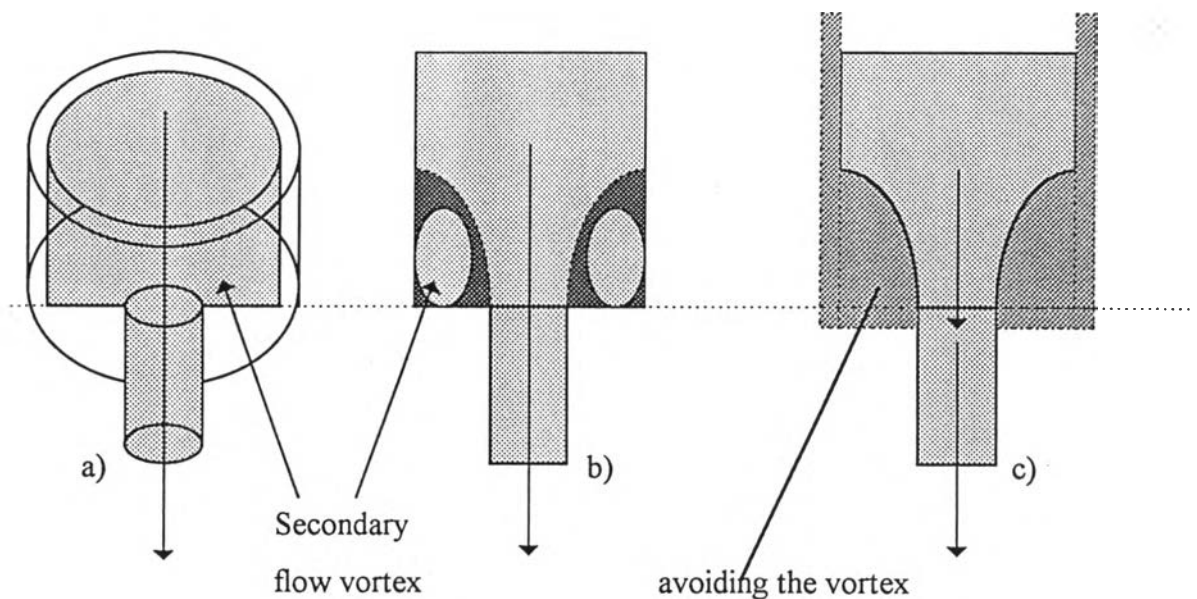

Figure 4.21 Rilling cup , Material : Stainless steel

Rilling cup is a container for the egg emulsion flow (compressed) from the compression tube (Figure 4.23). The egg emulsion comes in side the cup along the stainless steel connecting pipe and over flow the longitudinal slotted opening of that pipe. Until the egg emulsion fill in the cup, the pressure increases and force the egg emulsion throughout the rilling holes. The design of the hole is very difficult and there is no theoretical backup directly. For the case of the egg emulsion, not like the water and not like the plastic, the egg viscosity is also not too much different from the water and little elasticity (Chapter II-Viscosity). Therefore the design of the rilling cup for experiment is a modification and compare to the initial shape of a banana -leave cone. And the in side of the nozzle is design like this



Note: setting-up of rilling cup showed in Figure D12-D13-D14, Appendix D

Figure 4.22 Inside design of the rilling hole

- a) cylinder with 90° end
- b) secondary vortex occurs at around the corner
- c) avoiding of the vortex by designing inside curve (approximately)

4.4.3 Design of compression tube

Compression tube is located on the carriage which traverse longitudinally on the parallel rail above the set of the electric stove .There are some design criteria to be discussed at this stage.

4.4.3.1 Conceptual design

By supplying of the compression air, the pneumatic piston will be extracted and pushes the piston rod of the compression tube with. This action is called “suction stroke” The egg emulsion will be sucked from the egg container located on the top of the machine into the compression tube (through a one- way swing check valve) . While the pneumatic piston moves backwards, the piston of compression tube presses the egg-emulsion through the other one way valve into the rilling cup. The set of this tube should be designed for ease of assembly, disassembly, and maintenance.

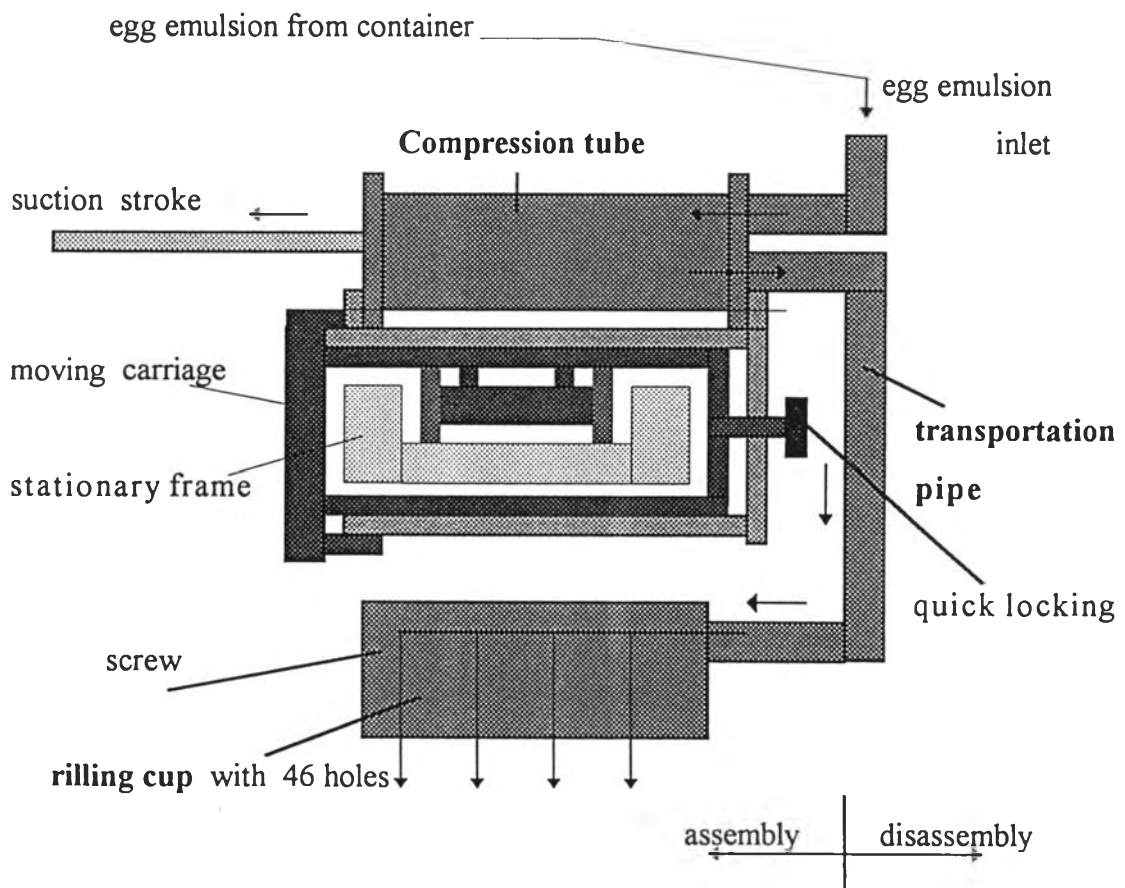

Figure 4.23 Conceptual design of the compression tube

The compression tube will be carried by a carriage running on a firmly - supported frame fixed to the machine column above the cooking pan.

4.4.3.2 Assembly design of compression tube

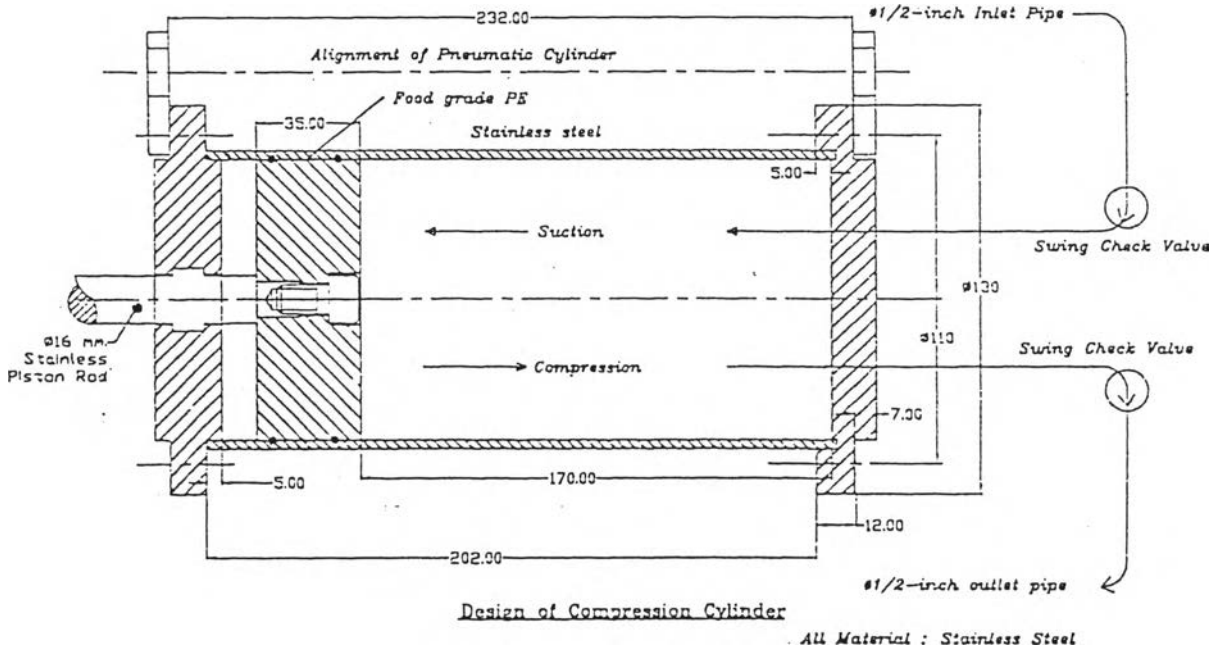

Figure 4.24 Design of the compression tube , material : all stainless steel

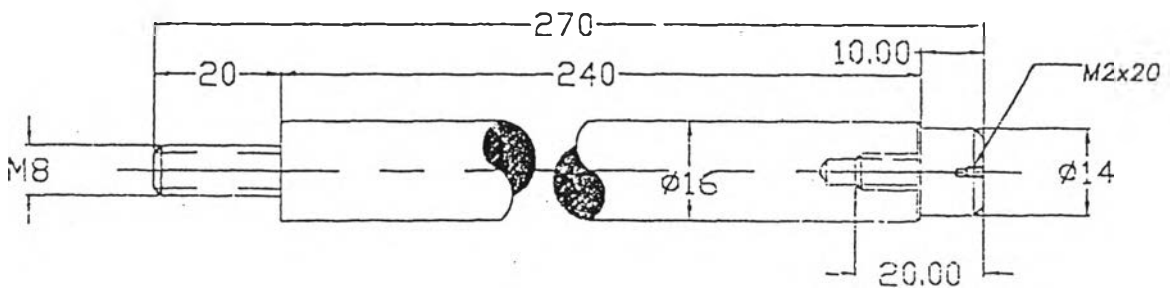

Figure 4.25 The piston rod , Material : stainless steel

Note : setting-up of compression tube showed in Figure D12...D16 ,Appendix D

4.4.4 Design of float switch

To control the syrup level, made by a common thin-wall brass tube and micro switch

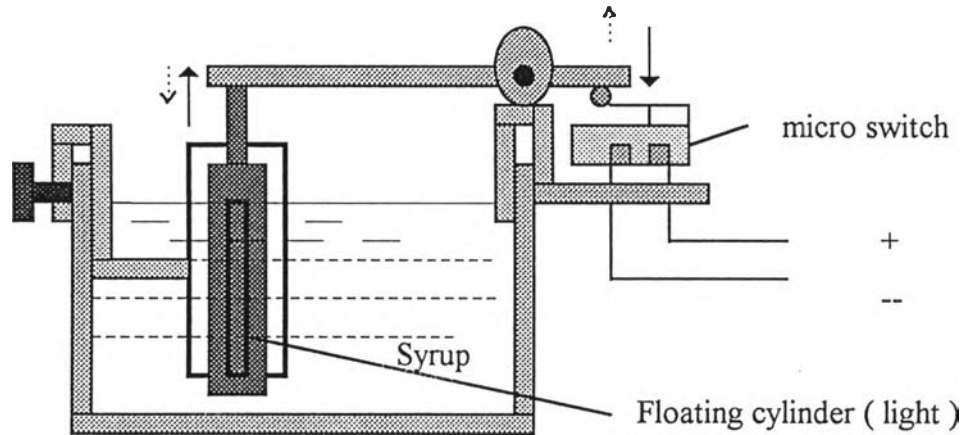

Figure 4.26 Floating switch

4.5 Design of control system

4.5.1. Pneumatic control system and its components

- Pneumatic control concept

Because of the compression air is needed to control the operation of the compression tube

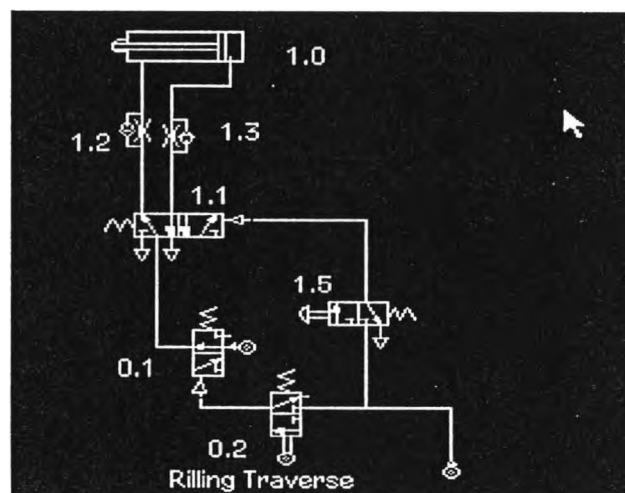

Figure 4.27 Pneumatic Diagram for the Rilling Cylinder

Table 4.6 Control system for pneumatic and its components

Number	Description
1.0	Pneumatic cylinder 25 mm bore size. Stroke 170 mm double acting.
1.1	4/2 direction valve actuated by pneumatically
1.2	Flow control valve, to control the velocity of piston during forward movement
1.3	Flow control valve, to control the velocity of piston during backward movement
0.1	A normally-closed 3/2 valve, to control the direction valve 1.1 which would be controlled by valve 0.2 (fixed on the back side of cylinder carriage)
0.2	the direction valve 0.2 would be pressed by either left or right stopping element located adjustably at the left and right -hand side at the end of the rail. Their function is to stop compressing air into the compression cylinder 1.0 at the left and the right end of its traverse (At this moment the rilling cup would be stopped inside the depot left or right-hand side respectively. In the above mentioned depots the machine performs; <ol style="list-style-type: none"> 1. Rilling holes underneath the rilling cup will be closed by spring pad. 2. Stop rilling as long as the timer setting 3. Stop compressing the egg emulsion
1.5	A 3/2 valve manual operated, to the start sucking egg-emulsion from container into the compression cylinder. In case the push button PB not operate, the compression cylinder would be in the compressing action

Note 1 : p : the compress air supply 1---7 bar

Note 2 : Installation of compression tube and control system
 showed in Figure D20-D21, Appendix D

4.5.2. Control system for motors and its components

There are two electrical circuits which perform the control function simultaneously

- Power circuit

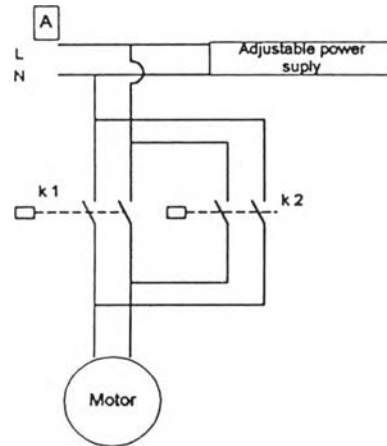

Figure 4.28 Power circuit

- component

Use 2 Relays 24 Volt DC 4 NC , 4 NO

- Condition of work

K1 is activated the motor rotates forwards

K2 is activated the motor rotates backwards

K1 and K2 can not be activated at the same time

- Control Circuit

To satisfy the working condition of K1 and K2 in power circuit, the control circuit is designed as follow.

- Component

T1 timer 1, T2 timer 2

L1 limit switch 1 (at the left hand size)

L2 limit switch 2 (at the right hand size)

S1 selected switch for starting, S2 stop switch

4.6 Design of electrical control circuit

In order to control the level of the syrup concentration , a closed loop system is required. But such a controller can be not found on the Thai market. The circuit model is therefore necessary to set up:

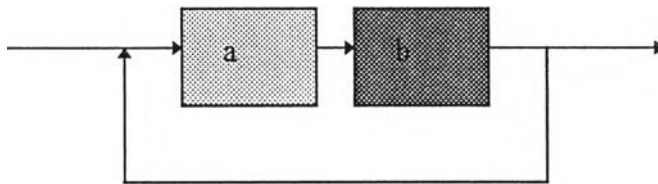

Figure 4.29 a closed loop control system consist of 2 main functions
 a) Flow control and concentration control circuit
 b) Valve control unit

4.6.1 Flow Control and concentration control circuit

The different resistance of the syrup will be the input feeding into the black box consists of input variable, unit transistor unit, relay unit, out put signal unit. The out put would be the anticipated concentration and the feed back signal as shown in the figure below :

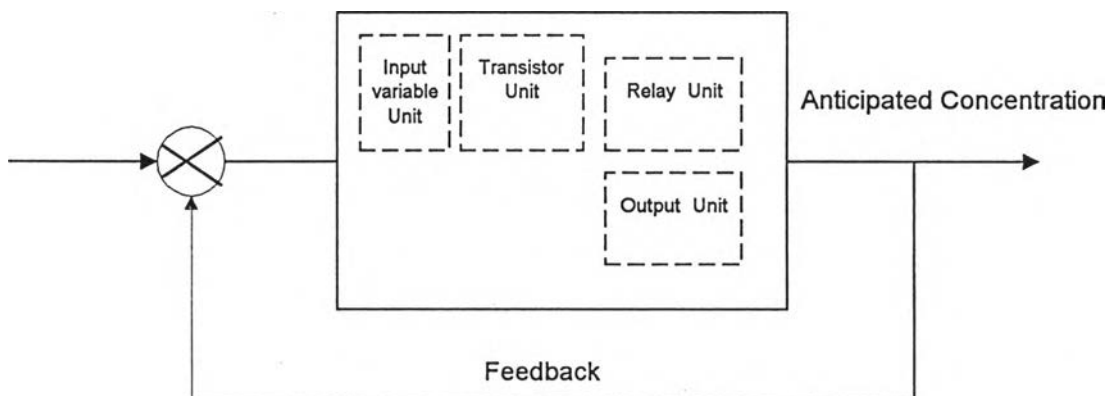
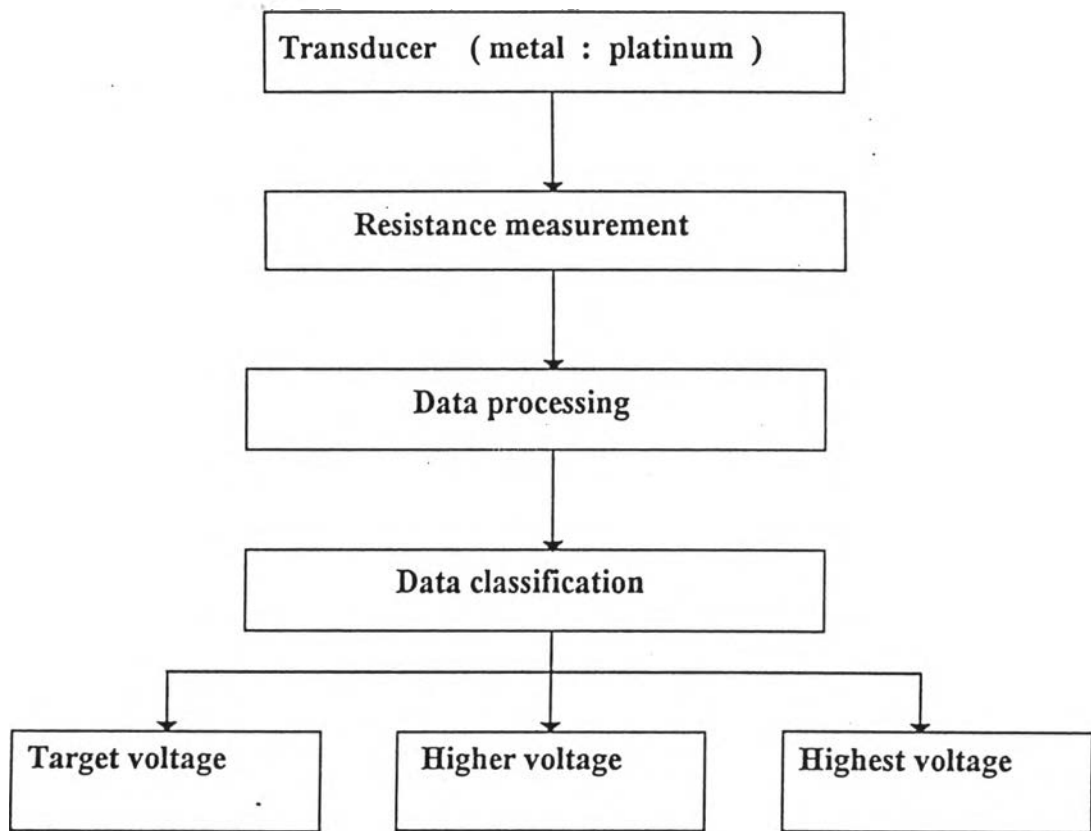

Figure 4.30 Flow control and concentration control circuit

- Block diagram for the syrup concentration control



Condition : Transister switch ON

- Electrical Variance (According to Data Sheet)

- Power supply : $V_{CC} = 12$ Volt. DC
- Drop voltage : $V_{BE} = 0.6$ Volt. DC
- Standard Voltage : $V_{CE} = 0.3$ Volt. DC
- Diode Voltage : $V_{LED} = 2.0$ Volt. DC
- Effective Current : $I_C = 10$ m A
- Effective Current : $I_B = 2$ m A

According to Ohm's Law ,

$$RI = U$$

$$R = \frac{U}{I} = \frac{V_{cc} - V_{led} - V_{ce}}{I_C}$$

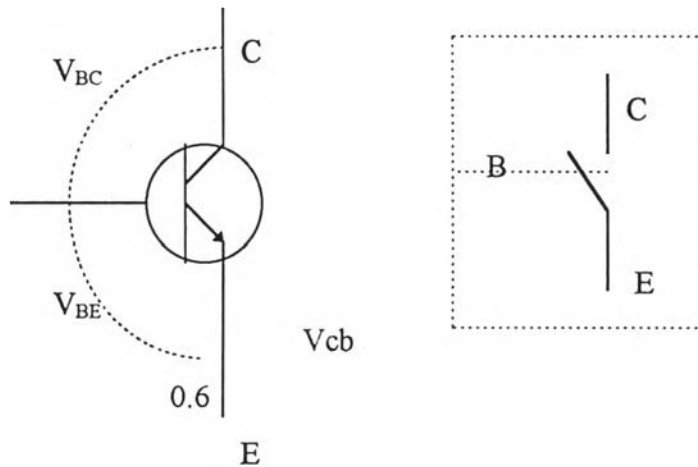

Transistor Symbol

Transistor Switch : ON

$$\begin{aligned} R_3 &= \frac{V_{cc} - V_{led} - V_{ce}}{I_C} \\ &= \frac{12\text{Volt} - 2\text{Volt} - 0.3\text{Volt}}{10\text{mA}} \\ &= 970 \Omega \end{aligned}$$

$$\text{Selected } R_3 = 1 \text{ k}\Omega$$

Resistance R_1

$$\begin{aligned} V_{R_1} + R_1 &= \frac{V}{I} = \frac{V_{cc} - V_{be}}{I_B} \\ &= \frac{12V - 0.6V}{2\text{mA}} \end{aligned}$$

$$V_{R_1} + R_1 = 5700 \Omega = 5.7 \text{ k}\Omega$$

In order to increase the measuring range for a higher accuracy, the resistance V_{R_1} which can be adjustable would be serial connected with the resistance R_1

The resistance of R_1 could be not cut off from the circuit, because of the current bias would damage the transistor, (over shoot of voltage)

Therefore, a constant resistor R_1 is to be added in series connection .

Suppose that the resistor $R_1 = 500 \Omega$ is connected to the circuit, in case of

adjusting $V_{R_1} = 0$
 the transistor is still saved by resistor $R_1 = (500 \Omega)$

$$I_B = \frac{V_{cc} - V_{BE}}{R_1}$$

$$= \frac{12V - 0.6V}{500 \Omega}$$

$$I_B = 0.022 A \approx 22 \text{ mA}$$

According to Data sheet : this transistor can consume $I_B > 22 \text{ mA}$

Hence, the resistor R_1 is therefore selected as

$$R_1 = 500 \Omega$$

• Definition of V_{R_1}

Since ; $R_1 = 500 \Omega : V_{R_1}=?$

$$V_{R_1} = (V_{R_1} + R_1) - R_1$$

$$= 5700 \Omega - 500 \Omega$$

$$= 5200 \Omega$$

$$V_{R_1} = 5.2 \text{ k}\Omega$$

Variable Resistance in market :

1 k Ω ; 5 k Ω ; 10 k Ω ; 20 k Ω ; 50 k Ω ; 100 k Ω ; 500 k Ω

Therefore, selected is

$$V_{R_1} = 10 \text{ k}\Omega$$

- Diode D_1 (A low voltage diode)

In order to protect the reverse voltage from Relay on which the voltage of 12 Vdc.

Selected : $D_1 = \text{IN4001}$, max. voltage 50 Vdc.

$$\begin{aligned} \text{Hence, } R_4 &= [V_{CC} - V_{LED}] / I_C \\ &= \frac{12V - 2V}{10 \text{ mA}} \end{aligned}$$

$$R_4 = 1000 \Omega = 1 \text{ k}\Omega$$

$$\text{Thus, } R_4 = 1 \text{ k}\Omega$$

4.6.2 Electronic circuit for controlling the syrup concentration

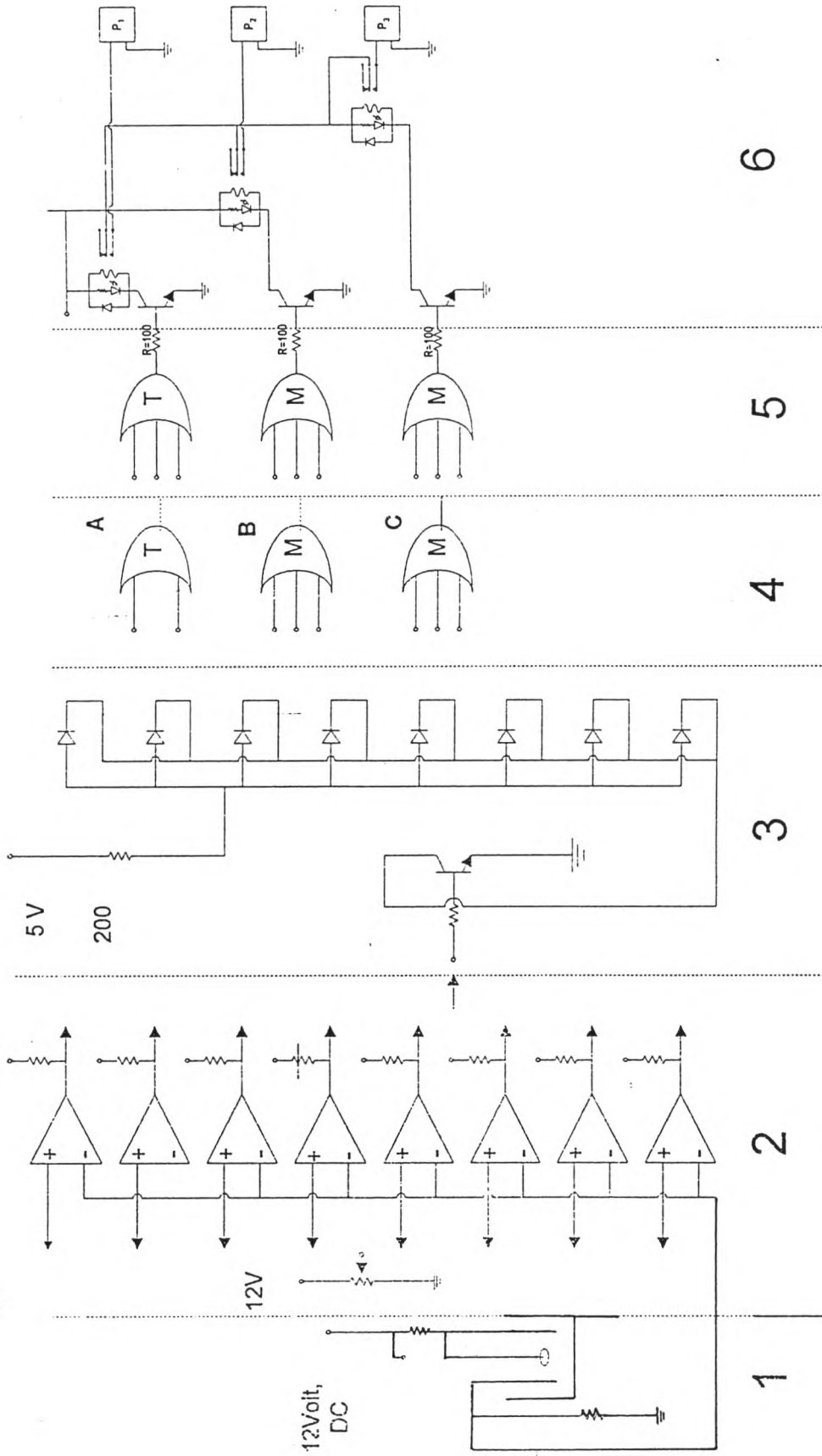

Figure 4.31 Electronic circuit for syrup concentration control

Figure 4.32 Logical matrix of the control circuit for P1, P2, P3

A	B	C	o/p
0	0	0	sel-1
0	0	1	P ₁
0	1	0	P ₂
1	0	0	P ₃

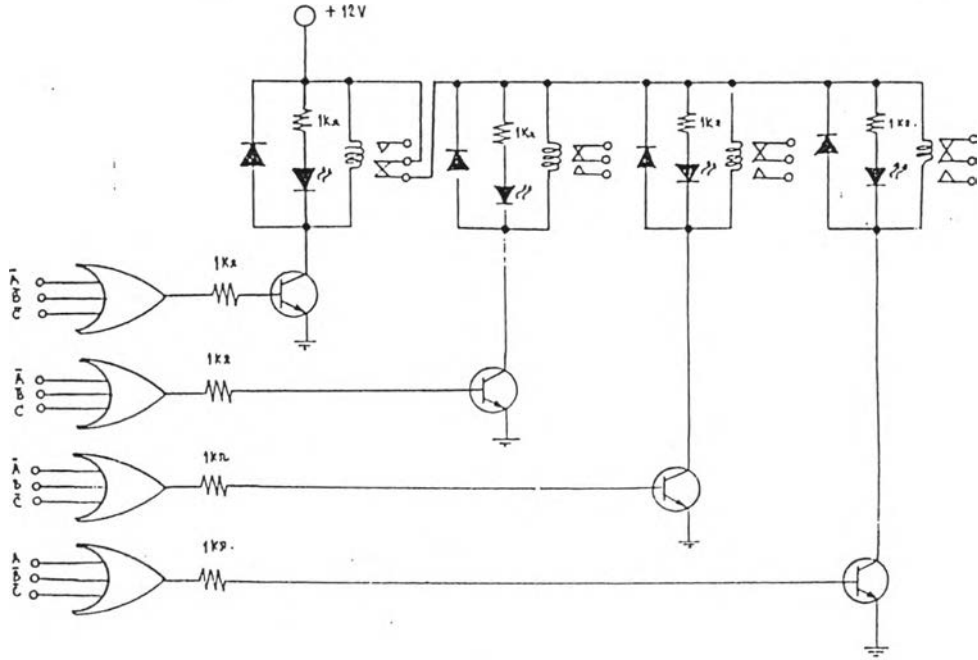
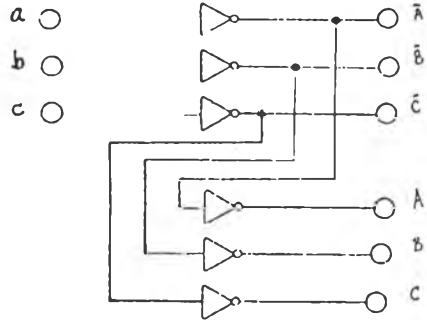
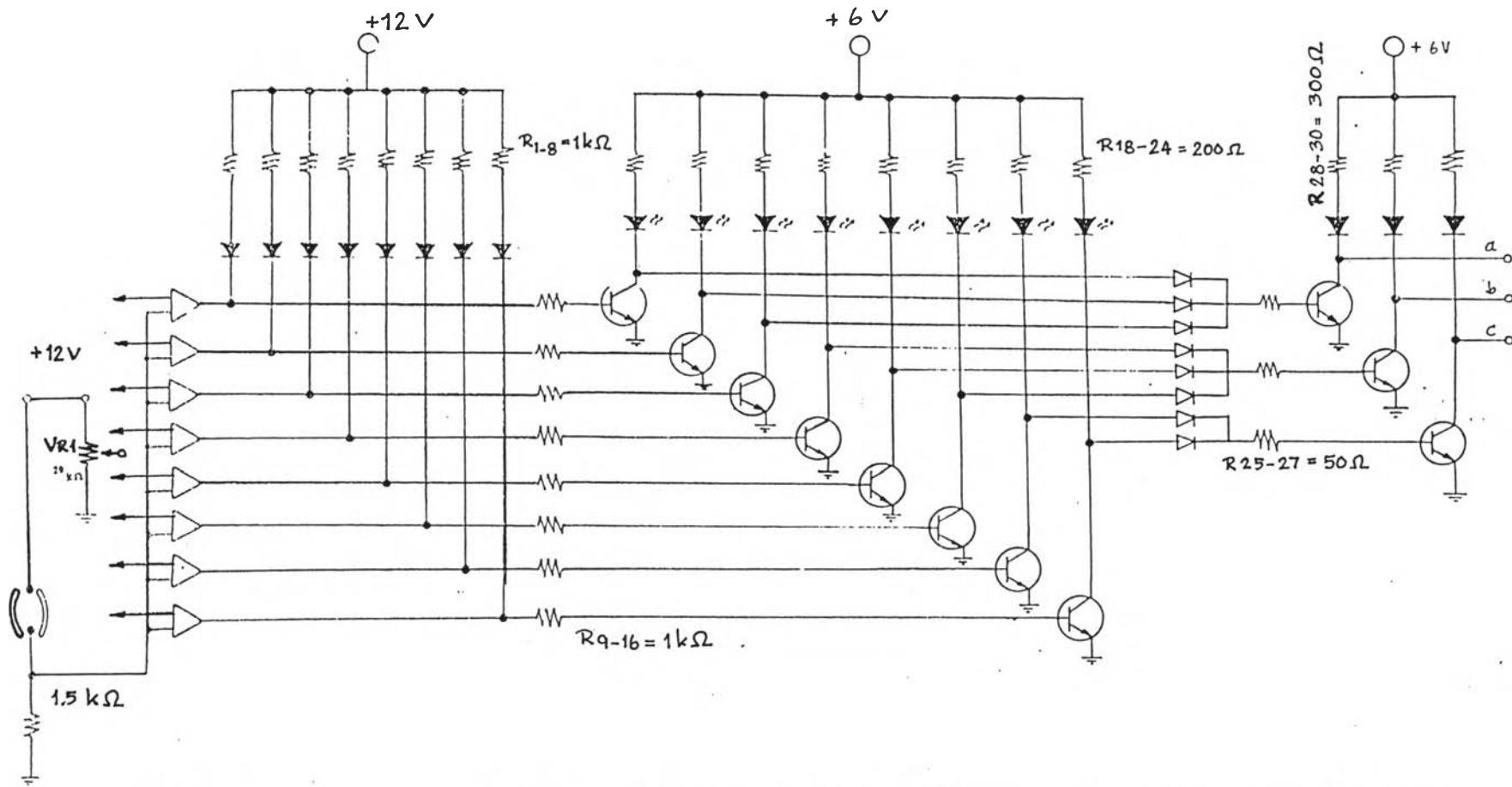

Figure 4.33 Electrical circuit with standard symbols



Notation :

- Op-Amp to compare the collected voltage with voltage drop in dividing resistance
- LED to indicate the concentration level (1—8)
- Transister to switch the LED indicators (1—8)
- IC-gate to perceive the LED output and transmit to control the motor pump P1, P2, P3

Figure 4.34

Inside of the control cabinet

(installed behind machine)

