

CHAPTER III

EXPERIMENTAL SECTION

3.1 Materials

Three different surfactants were chosen for study. Sodium dodecyl sulfate (SDS) was supplied from Kao industrial R&D with a purity of 96.28%. Cetylpyridinium chloride (CPC) from PFALTZ & BAUER Inc. was 99.9% pure. Sodium n-hexadecyl di-phenyloxide disulfonate (DADS, trade name Dowfax-8390) was supplied from Dow Chemical and had a purity of 36.5% by weight. Sodium chloride (NaCl) was supplied from Ajax Chemical with a purity of 99.9%. All of the above materials were used without further purification. Distillated water with conductivity of 2 $\mu\text{moh/cm}$ was used in all experiments. Manufacturer-supplied information about the surfactants used is shown in Table 3.1.

3.2 Equipment

A schematic flow diagram of the foam fractionation apparatus used in this study is shown in Fig. 3.1. The jacketed cylindrical fractionator column consisted of two 100 cm long acrylic columns with diameters of 12 cm and 15 cm diameter, and a thickness of 3 mm. The feed stream tube, drainage stream tube, and cooling water tube are made of acrylic with 1.5 cm O.D. and 15 cm length. For the foam outlet tube, an acrylic tube with 2.5 cm O.D. and 15 cm length was used.

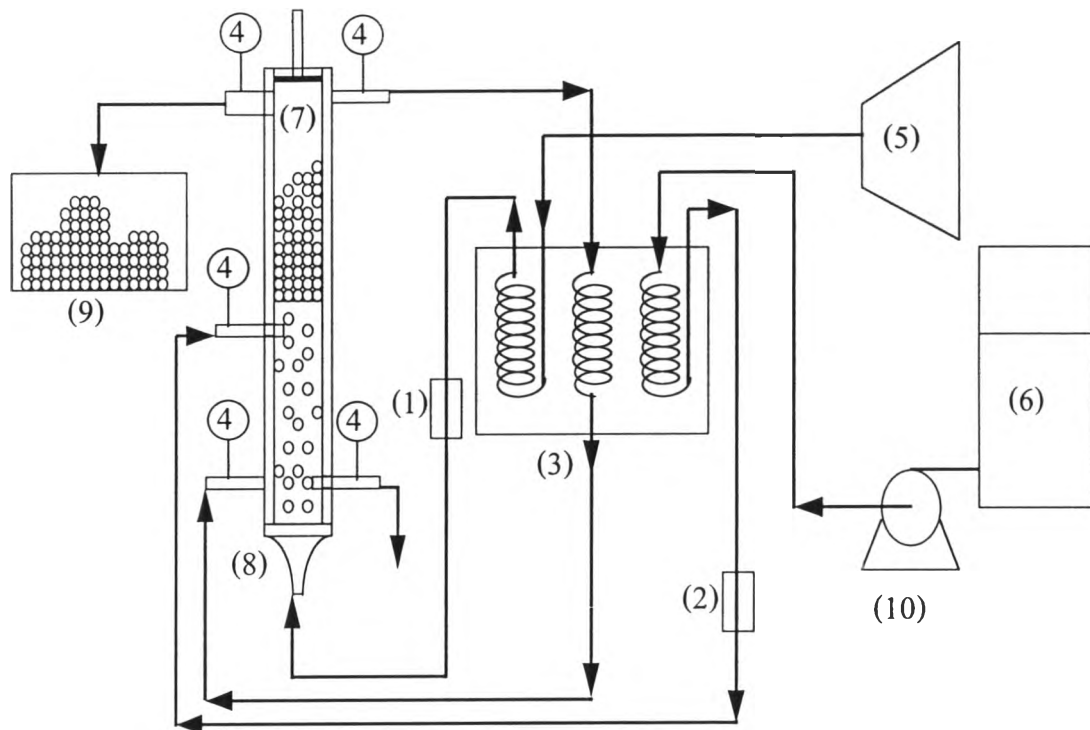

Fig. 3.1 Schematic diagram of foam fractionation system.

Equipment:

- | | |
|---------------------------------------|-------------------------------|
| (1) Flow meter | (6) Feed storage tank |
| (2) Air flow meter | (7) Foam fractionation column |
| (3) Circulated heating & cooling bath | (8) Sintered-glass diffuser |
| (4) Thermocouple | (9) Foam storage collector |
| (5) Air compressor | (10) Diaphragm pump |

Table 3.1 Information on manufacture-supplied surfactant properties

CHEMICAL	FORMULAR WEIGHT	QUALITY	SOURCE
Sodium dodecyl sulfate (SDS)	288.38	96.28% SDS 1.12% volatile matter 0.39% N-hexane 2.207% SO ₄	Kao Industrial (Emal 10 P) Lot No. 611
Cetylpyridinium chloride (CPC)	358.01	>99.9% pure	Pfaltz&Bauer Inc.
Sodium n-hexadecyl diphenyloxide disulfonate (DADS)	640	36.5% wt active 10% NaCl 0.51% Na ₂ SO ₄	Dow Chemical
Sodium chloride (NaCl)	58.44	99.9% pure	Ajax Chemical

3.3 Experimental method

The simple continuous mode of foam fractionation system was used in this study, as shown in Fig. 3.1. The surfactant feed solution was continuously pumped through a flow meter at a flowrate of 100 mL/min (10 L/min.m²) by a diaphragm pump before entering the column at a position of 40 cm from the bottom of the column. The liquid level in the column was controlled at a position of 45 cm height by adjustment of the bottom stream withdrawal rate. The compressed air was allowed to pass through the air flow meter at the flowrate of 200 mL/min and was introduced to the column through a sinter-glass diffuser. The sinter-glass No.2 was used to produce bubble sizes of 100-

160 microns. Foamate at the top of the solution was collected at a position 45 cm from the liquid surface. It was received by beaker for measured time period. The foam was frozen, thawed, and then weighted to get the collapsed foamate volume. The column operating temperature was held at the desired value by using a circulated cooling-heating bath and the water jacket around the column. The temperature at any point around this column was measured continuously by a scanning thermocouple thermometer.

The foam fractionation was studied under steady state conditions. The base condition was 200 mL/min (20 L/min.m²) air flow rate, 100 mL/min (10 L/min.m²) liquid feed flow rate, 20 °C, 45 cm foam height, and 45 cm liquid height. The surfactant concentration in the feed solution was kept at 80% of the CMC of each surfactant when the effects of temperature were studied. In studies of the effects of added salt, the surfactant concentration was held at 10% of the CMC (with no added salt) for SDS and CPC, and 20% of the CMC (in the absence of added salt) for DADS to avoid the micelles formation. Each experiment was carried out for a minimum of 3 hours. Steady-state was insured when all measured parameters were invariant with time.

Three parameters, volumetric foam production rate (L/min.m²), foam wetness (grams of foam solution/L of foam), and the surfactant concentration (grams/L) in the collapsed foam solution were measured. The concentration of CPC and DADS were determined by UV visible spectroscopy at wavelengths of 260 and 237 nm. respectively, while SDS concentration was measured by High Performance Liquid Chromatography (HPLC) or Total Organic Carbon analyzer (TOC).

The CMC of each surfactant was calculated as the concentration where the specific surface tension versus surfactant concentration showed an abrupt change in slope.