

## CHAPTER IV

### RESULTS AND DISCUSSION

#### 4.1 Simulating Data of a Hot-oil Heat Exchanger as a Case Study

(Some information is based on PTTGSP5)

##### 4.1.1 Generating Simulated Values (True Values)

**Model A:** Ethane product heater

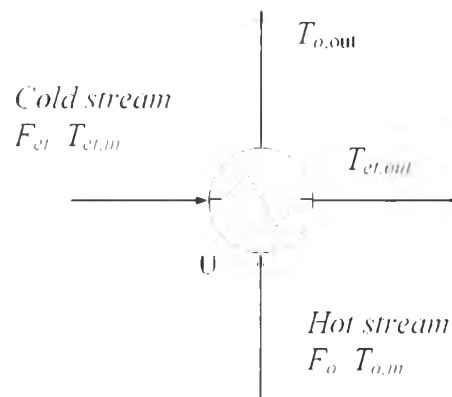

**Figure 4.1** Measured variables of a hot-oil heat exchanger (Model A).

where  $F_o$  is volumetric flowrate of hot oil ( $\text{m}^3/\text{h}$ )  
 $T_{o,m}$  is inlet temperature of hot oil ( $^{\circ}\text{C}$ )  
 $T_{o,out}$  is outlet temperature of hot oil ( $^{\circ}\text{C}$ )  
 $F_{et}$  is volumetric flowrate of ethane products ( $\text{Nm}^3/\text{h}$ )  
 $T_{et,m}$  is inlet temperature of ethane products ( $^{\circ}\text{C}$ )  
 $T_{et,out}$  is outlet temperature of ethane products ( $^{\circ}\text{C}$ )  
 $U$  is overall heat transfer coefficient ( $\text{W}/\text{m}^2 \text{ } ^{\circ}\text{C}$ )

The true values of each variable were generated by fixing the values of hot-oil volumetric flowrate, hot-oil inlet temperature, volumetric flowrate of ethane products, inlet temperature of ethane products and overall heat transfer

coefficient first and adjusted the value of heat exchanger area closely to  $46.1 \text{ m}^2$  by using goal seek technique. The physical data and the all of simulated values (true values) are shown in Tables 4.1 and 4.2, respectively.

**Table 4.1** Physical data of a hot-oil heat exchanger (Model A)

Physical Data	Value
$C_{p,oil}$ (kJ/kg °C)	2.419
$\rho_{oil}$ (kg/m <sup>3</sup> )	772.650
$C_{p,et}$ (kJ/kg °C)	2.473
$\rho_{et}$ (kg/m <sup>3</sup> )	1.334
$A$ (m <sup>2</sup> )	46.1

**Table 4.2** True values of a hot-oil heat exchanger (Model A)

Variable	True value
$F_o$ (m <sup>3</sup> /h)	39.384
$T_{o,m}$ (°C)	169.430
$T_{o,out}$ (°C)	101.112
$F_{et}$ (m <sup>3</sup> /h)	35538.777
$T_{et,m}$ (°C)	15.723
$T_{et,out}$ (°C)	58.612
$U$ (W/m <sup>2</sup> °C)	310.60
$Q$ (W)	1396813.653

#### 4.1.2 Generating Random Errors

A Gaussian random number generator was used as a tool to generate the random errors into the true values in this research by following the assumptions below.

- a. Generating 365 data (1 year) distributed with normal distribution from <http://www.random.org>.

b. The standard deviation values which used in each of indicator depend on the size of true values of them, if the magnitude of true values is less than 100, then used the standard deviation of 10 but others used the standard deviation of 25.

- Using standard deviation of  $10 \text{ m}^3/\text{h}$  for hot stream volumetric flowrate indicator and  $10 \text{ }^\circ\text{C}$  for cold temperature indicator.

- Using standard deviation of  $25 \text{ m}^3/\text{h}$  for cold stream volumetric flowrate indicator,  $25 \text{ }^\circ\text{C}$  for hot temperature indicator and  $25 \text{ W/m}^2 \text{ }^\circ\text{C}$  for heat transfer coefficient indicator (no gross error at this indicator).

And the average measured values (including random error only) of these variables for Model A are shown in Table 4.3

**Table 4.3** Measured values of a hot-oil heat exchanger (Model A)

Variable	Standard deviation	Average Measured value
$F_h \text{ (m}^3/\text{h)}$	10.094	40.093
$F_{ct} \text{ (m}^3/\text{h)}$	25.249	35540.356
$T_{o,m} \text{ (}^\circ\text{C)}$	24.940	169.595
$T_{o,out} \text{ (}^\circ\text{C)}$	24.428	100.371
$T_{ct,m} \text{ (}^\circ\text{C)}$	9.799	16.402
$T_{ct,out} \text{ (}^\circ\text{C)}$	10.239	58.702
$U \text{ (W m}^2 \text{ }^\circ\text{C)}$	25.483	310.29

#### 4.1.3 Generating Gross Errors

An integer random number generator from random.org., where the randomness comes from atmospheric noise, and it is better than the pseudo-random number algorithms typically used in simulated program, was used as a tool to generate gross errors for the measured values in this research by following assumptions below.

a. The magnitude of gross error was allowed to vary between approximately 1 to 300% of the true values; these magnitudes were used in an integer random number generator to generate the gross error number (the allowed smallest measured value was zero, corresponding to total instrument failure).

- The magnitude of gross error was added to measured values of  $F_o$  and  $T_{et,m}$  (average magnitude sizes are equal to 59.608 m<sup>3</sup>/h and 22.646 °C, respectively) as shown in Figures 4.2 and 4.3, respectively.

b. For NLP data reconciliation when the gross errors existed in the system, lower and upper bounds of variables were set at 1.3 and 0.7 times corresponding to true values.

And the average measured values with one position of gross error (including gross error only at  $F_o$ ) and with two positions of gross errors (including gross error at  $F_o$  and  $T_{et,m}$ ) for Model A are shown in Tables 4.4 and 4.5, respectively.

**Table 4.4** Measured values of a hot-oil heat exchanger (Model A): including gross-error only at  $F_o$

Variable	Standard deviation	Average Measured value
$F_o$ (m <sup>3</sup> /h)*	36.227	99.701
$F_{et}$ (m <sup>3</sup> /h)	25.249	35540.356
$T_{o,m}$ (°C)	24.940	169.595
$T_{o,out}$ (°C)	24.428	100.371
$T_{et,m}$ (°C)	9.799	16.402
$T_{et,out}$ (°C)	10.239	58.702
$U$ (W/m <sup>2</sup> °C)	25.483	310.29

**Table 4.5** Measured values of a hot-oil heat exchanger (Model A): including gross-error at  $F_o$  and  $T_{et,in}$

<b>Variable</b>	<b>Standard deviation</b>	<b>Average Measured value</b>
$F_o$ (m <sup>3</sup> /h)*	36.227	99.701
$F_{et}$ (m <sup>3</sup> /h)	25.249	35540.356
$T_{o,m}$ (°C)	24.940	169.595
$T_{o,out}$ (°C)	24.428	100.371
$T_{et,m}$ (°C)*	16.951	39.048
$T_{et,out}$ (°C)	10.239	58.702
$U$ (W/m <sup>2</sup> °C)	25.483	310.29

*Remark: \* consisting of bias or gross errors*

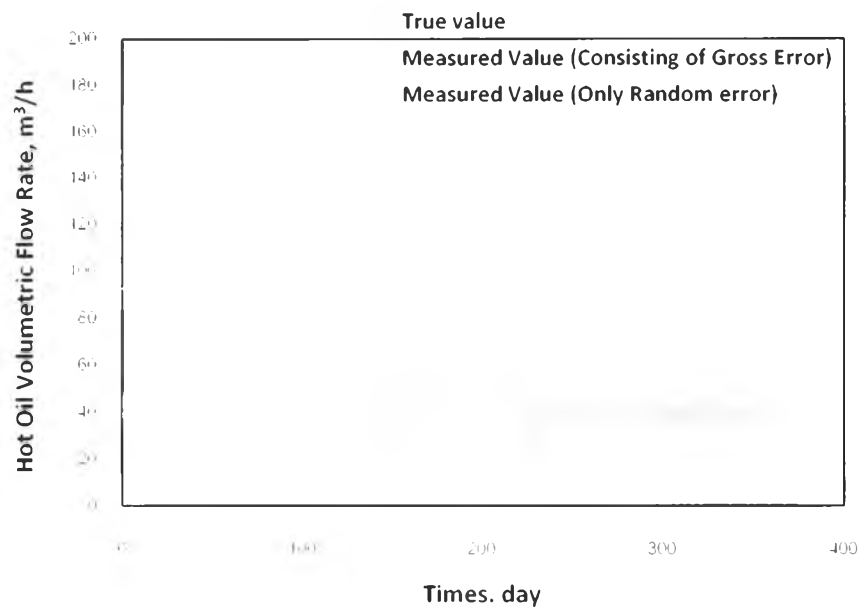

**Figure 4.2** True value, measured value and some bias of hot-oil volumetric flow rate variable,  $F_o$  (Model A).

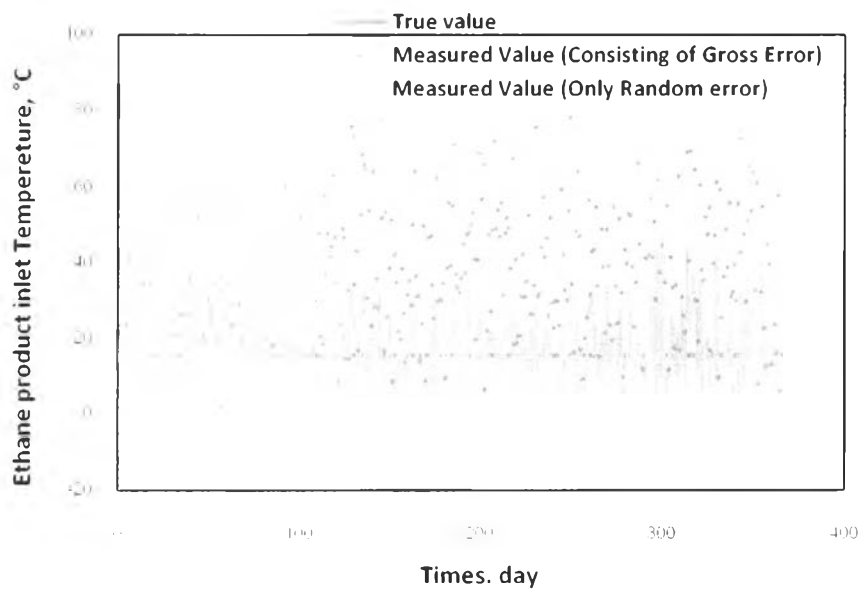

**Figure 4.3** True value, measured value and some bias of ethane product inlet temperature variable,  $T_{el,m}$  (Model A).

#### 4.2 Data Reconciliation Technique (for Model A)

For a hot-oil heat exchanger (Model A), there are 8 process variables which are  $F_h$  (flowrate of hot stream),  $F_c$  (flowrate of cold stream),  $T_{h\ in}$  (inlet temperature of hot stream),  $T_{h\ out}$  (outlet temperature of hot stream),  $T_{c\ in}$  (inlet temperature of cold stream),  $T_{c\ out}$  (outlet temperature of cold stream),  $U$  (overall heat transfer coefficient) and  $Q$  (heat duty) and there are 3 equations which are the heat duty of hot stream (hot oil), cold stream and heat exchanger as shown in equation 4.4, 4.5 and 4.6, respectively. Degree of freedom (DOF), which is the minimum number of variables required to calculate all of system variables, or the difference between number of variables (including measured and unmeasured variables) and number of equations, need to be calculated, the other parameter called degree of redundancy (DOR) is the difference between number of measured variables and degree of freedom. Data reconciliation can be performed if degree of redundancy is greater than or equal to 1 ( $DOR \geq 1$ ). The greater value of DOR represents more accuracy in doing the data reconciliation technique.

$$\text{Degree of freedom (DOF)} = \text{no. of variables} - \text{no. of equations} \quad (4.1)$$

$$\text{Degree of redundancy (DOR)} = \text{no. of measured variables} - \text{DOF} \quad (4.2)$$

For a hot-oil heat exchanger (Model A)

$$\begin{aligned} \text{Degree of freedom (DOF)} &= \text{no. of variables} - \text{no. of equations} \\ &= 8 - 3 = 5 \end{aligned}$$

$$\begin{aligned} \text{Degree of redundancy (DOR)} &= \text{no. of measured variables} - \text{DOF} \\ &= 7 - 5 = 2 \end{aligned}$$

In the case of a hot-oil heat exchanger (Model A), DOF is equal to 5 and DOR is equal to 2. To do data reconciliation, DOR must be greater than or equal to 1 ( $DOR \geq 1$ ) or we need at least 6 measured variables to do data reconciliation for this model at the beginning of eliminating gross error.

Concept of data reconciliation is to minimize the difference between measured values and reconciled values or true values by using the objective function as shown below:

Objective function:

$$\begin{aligned} \text{Min} \sum \left( \frac{F_h - Fr_h}{\sigma_{F_h}} \right)^2 + \sum \left( \frac{F_c - Fr_c}{\sigma_{F_c}} \right)^2 + \sum \left( \frac{T_{h,in} - Tr_{h,in}}{\sigma_{T_{h,in}}} \right)^2 + \sum \left( \frac{T_{h,out} - Tr_{h,out}}{\sigma_{T_{h,out}}} \right)^2 \\ + \sum \left( \frac{T_{c,in} - Tr_{c,in}}{\sigma_{T_{c,in}}} \right)^2 + \sum \left( \frac{T_{c,out} - Tr_{c,out}}{\sigma_{T_{c,out}}} \right)^2 + \sum \left( \frac{Y - Yr}{\sigma_Y} \right)^2 \end{aligned} \quad (4.3)$$

- Where  $F_h$  is volumetric flowrate of hot stream ( $\text{m}^3/\text{h}$ )  
 $Fr_h$  is reconciled value of volumetric flowrate of hot stream ( $\text{m}^3/\text{h}$ )  
 $F_c$  is volumetric flowrate of cold stream ( $\text{m}^3/\text{h}$ )  
 $Fr_c$  is reconciled value of volumetric flowrate of cold stream ( $\text{m}^3/\text{h}$ )  
 $T_{h,m}$  is inlet temperature of hot stream ( $^{\circ}\text{C}$ )  
 $Tr_{h,m}$  is reconciled value of inlet temperature of hot stream ( $^{\circ}\text{C}$ )  
 $T_{h,out}$  is outlet temperature of hot stream ( $^{\circ}\text{C}$ )  
 $Tr_{h,out}$  is reconciled value of outlet temperature of hot stream ( $^{\circ}\text{C}$ )  
 $T_{c,m}$  is inlet temperature of cold stream ( $^{\circ}\text{C}$ )  
 $Tr_{c,m}$  is reconciled value of inlet temperature of cold stream ( $^{\circ}\text{C}$ )  
 $T_{c,out}$  is outlet temperature of cold stream ( $^{\circ}\text{C}$ )  
 $Tr_{c,out}$  is reconciled value of outlet temperature of cold stream ( $^{\circ}\text{C}$ )  
 $Y$  is the other measured variables  
 $Yr$  is reconciled value of the other measured variables

Objective function for a hot-oil hot exchanger (Model A) is shown in equation 4.3-1.

$$\begin{aligned} \text{Min} \left( \frac{F_{oil} - Fr_{oil}}{\sigma_{F_{oil}}} \right)^2 + \left( \frac{F_{et} - Fr_{et}}{\sigma_{F_{et}}} \right)^2 + \left( \frac{T_{o,in} - Tr_{o,in}}{\sigma_{T_{o,in}}} \right)^2 + \left( \frac{T_{o,out} - Tr_{o,out}}{\sigma_{T_{o,out}}} \right)^2 \\ + \left( \frac{T_{et,in} - Tr_{et,in}}{\sigma_{T_{et,in}}} \right)^2 + \left( \frac{T_{et,out} - Tr_{et,out}}{\sigma_{T_{et,out}}} \right)^2 + \left( \frac{U - Ur}{\sigma_U} \right)^2 \end{aligned} \quad (4.3-1)$$



Heat transfer of these systems must be the same, so the actual heat transfer may be calculated by energy balance. Equation 4.4, 4.5, and 4.6 are heat duty of hot stream (hot oil), cold stream and heat exchanger, respectively. Equation 4.7, 4.8, 4.9 and 4.10 are inequality constraints.

Constraints:

$$Q = M_o C_{p,o} \Delta T_o \quad (4.4)$$

$$Q = M_{et} C_{p,et} \Delta T_{et} \quad (4.5)$$

$$Q = UA(LMTD) \quad (4.6)$$

*\*Remark: All of heat capacities, areas and overall heat transfer coefficients are assumed to be constant*

Inequality constraints:

$$T_{o,in} \geq T_{et,out} \quad (4.7)$$

$$T_{o,out} \geq T_{et,in} \quad (4.8)$$

$$T_{o,in} \geq T_{o,out} \quad (4.9)$$

$$T_{et,out} \geq T_{et,in} \quad (4.10)$$

Where  $Q$  is heat duty (W)

$M_o$  is mass flowrate of hot oil (kg/h)

$M_{et}$  is mass flowrate of cold ethane (kg/h)

$C_{p,o}$  is specific heat capacity of hot oil (kJ/kg °C)

$C_{p,et}$  is specific heat capacity of cold ethane (kJ/kg °C)

$U$  is overall heat transfer coefficient (W/m<sup>2</sup> °C)

$A$  is area of heat exchanger (m<sup>2</sup>)

$LMTD$  is log-mean temperature difference (°C)

Chen's approximation (Chen, 1988) was used to calculate log-mean temperature difference as shown in equation 4.11 and equation 4.11-a was used to calculate LMTD of a hot-oil heat exchanger (Model A)

$$LMTD = \left[ (T_{h,in} - T_{c,out}) \times (T_{h,out} - T_{c,in}) \times \frac{(T_{h,in} - T_{c,out}) + (T_{h,out} - T_{c,in})}{2} \right]^{1/3} \quad (4.11)$$

$$LMTD = \left[ (T_{o,in} - T_{et,out}) \times (T_{o,out} - T_{et,in}) \times \frac{(T_{o,in} - T_{et,out}) + (T_{o,out} - T_{et,in})}{2} \right]^{1/3} \quad (4.11-a)$$

In this work, General Algebraic Modeling System (GAMS) program was used to perform data reconciliation by minimizing the objective function (Equation 4.3-1) with the reconciled values of flow rates, inlet and outlet temperature of hot oil and cold process streams suitable for process constraints (Equation 4.4 to 4.10).

#### Model A:

**Table 4.6** First reconciliation of process variables in a hot-oil heat exchanger (Model A) with only random errors occurring in the measurement

Variable	Symbol	True value	Avg.Measured value	Reconciled values	Relative Error
Hot-oil volumetric flow rate (m <sup>3</sup> /h)	$F_o$	39.384	40.093	38.360	2.669%
Ethane product volumetric flow rate (m <sup>3</sup> /h)	$F_{et}$	35538.777	35540.356	35540.356	0.0044%
Hot-oil inlet temperature (°C)	$T_{o,in}$	169.430	169.595	168.930	0.296%
Hot-oil outlet temperature (°C)	$T_{o,out}$	101.112	100.371	96.602	4.670%
Ethane product inlet temperature (°C)	$T_{et,in}$	15.723	16.402	14.284	10.074%
Ethane product outlet temperature (°C)	$T_{et,out}$	58.612	58.702	58.643	0.053%
Heat duty of hot stream (W)	$Q$				
Heat duty of cold stream (W)	$Q$	1396813.653	-	1362328.391	2.531%
Heat duty of heat exchanger (W)	$Q$				
Overall heat transfer coefficient (W m <sup>2</sup> °C)	$U$	310.60	310.29	309.05	0.501%

Remark: Objective function value, calculated from Equation 4.3-1, is equal to 0.206

**Table 4.7** First reconciliation of process variables in a hot-oil heat exchanger (Model A) with both random errors and one gross error only at  $F_o$

Variable	Symbol	True value	Avg. Measured value	Reconciled values	Relative Error
Hot-oil volumetric flow rate ( $\text{m}^3/\text{h}$ )	$F_o$	39.384	99.701	41.679	5.506%
Ethane product volumetric flow rate ( $\text{m}^3/\text{h}$ )	$F_{et}$	35538.777	35540.356	35537.640	0.0032%
Hot-oil inlet temperature ( $^{\circ}\text{C}$ )	$T_{o,in}$	169.430	169.595	162.724	4.121%
Hot-oil outlet temperature ( $^{\circ}\text{C}$ )	$T_{o,out}$	101.112	100.371	98.060	3.112%
Ethane product inlet temperature ( $^{\circ}\text{C}$ )	$T_{et,in}$	15.723	16.402	15.484	1.544%
Ethane product outlet temperature ( $^{\circ}\text{C}$ )	$T_{et,out}$	58.612	58.702	58.702	0.153%
Heat duty of hot stream (W)	$Q$				
Heat duty of cold stream (W)	$Q$	1396813.653	-	1324778.514	5.438%
Heat duty of heat exchanger (W)	$Q$				
Overall heat transfer coefficient ( $\text{W}/\text{m}^2\text{C}$ )	$U$	310.60	310.29	309.38	0.394%

Remark: Objective function value, calculated from Equation 4.3-1, is equal to 16.892

**Table 4.8** First reconciliation of process variables in a hot-oil heat exchanger (Model A) with both random errors and two gross errors at  $F_o$  and  $T_{et,in}$

Variable	Symbol	True value	Avg. Measured value	Reconciled values	Relative Error
Hot-oil volumetric flow rate ( $\text{m}^3/\text{h}$ )	$F_o$	39.384	99.701	38.619	1.981%
Ethane product volumetric flow rate ( $\text{m}^3/\text{h}$ )	$F_{et}$	35538.777	35540.356	35540.356	0.0044%
Hot-oil inlet temperature ( $^{\circ}\text{C}$ )	$T_{o,in}$	169.430	169.595	168.388	0.619%
Hot-oil outlet temperature ( $^{\circ}\text{C}$ )	$T_{o,out}$	101.112	100.371	96.544	4.732%
Ethane product inlet temperature ( $^{\circ}\text{C}$ )	$T_{et,in}$	15.723	39.048	13.919	12.961%
Ethane product outlet temperature ( $^{\circ}\text{C}$ )	$T_{et,out}$	58.612	58.702	58.224	0.666%
Heat duty of hot stream (W)	$Q$				
Heat duty of cold stream (W)	$Q$	1396813.653	-	1362250.367	2.537%
Heat duty of heat exchanger (W)	$Q$				

Variable	Symbol	True value	Avg.Measured value	Reconciled values	Relative Error
Overall heat transfer coefficient (W m <sup>-2</sup> °C)	$U$	310.60	310.29	308.66	0.627%

*Remark: Objective function value, calculated from Equation 4.3-1, is equal to 10.148*

### 4.3 Gross Error Detection (for Model A)

#### 4.3.1 The Conventional Gross Error Detection

Concept of the conventional gross error detection is to detect the systematic gross error by using some methods called Global Test (GT) and/or Measurement Test (MT) using only the basic statistical concept of them. The Global Test is the statistical test to find the gross error occurring in the system but it cannot identify where gross errors are, so the technique called Measurement test was used to identify the position of gross errors, where the algorithm of this technique is shown in Figure 4.4.

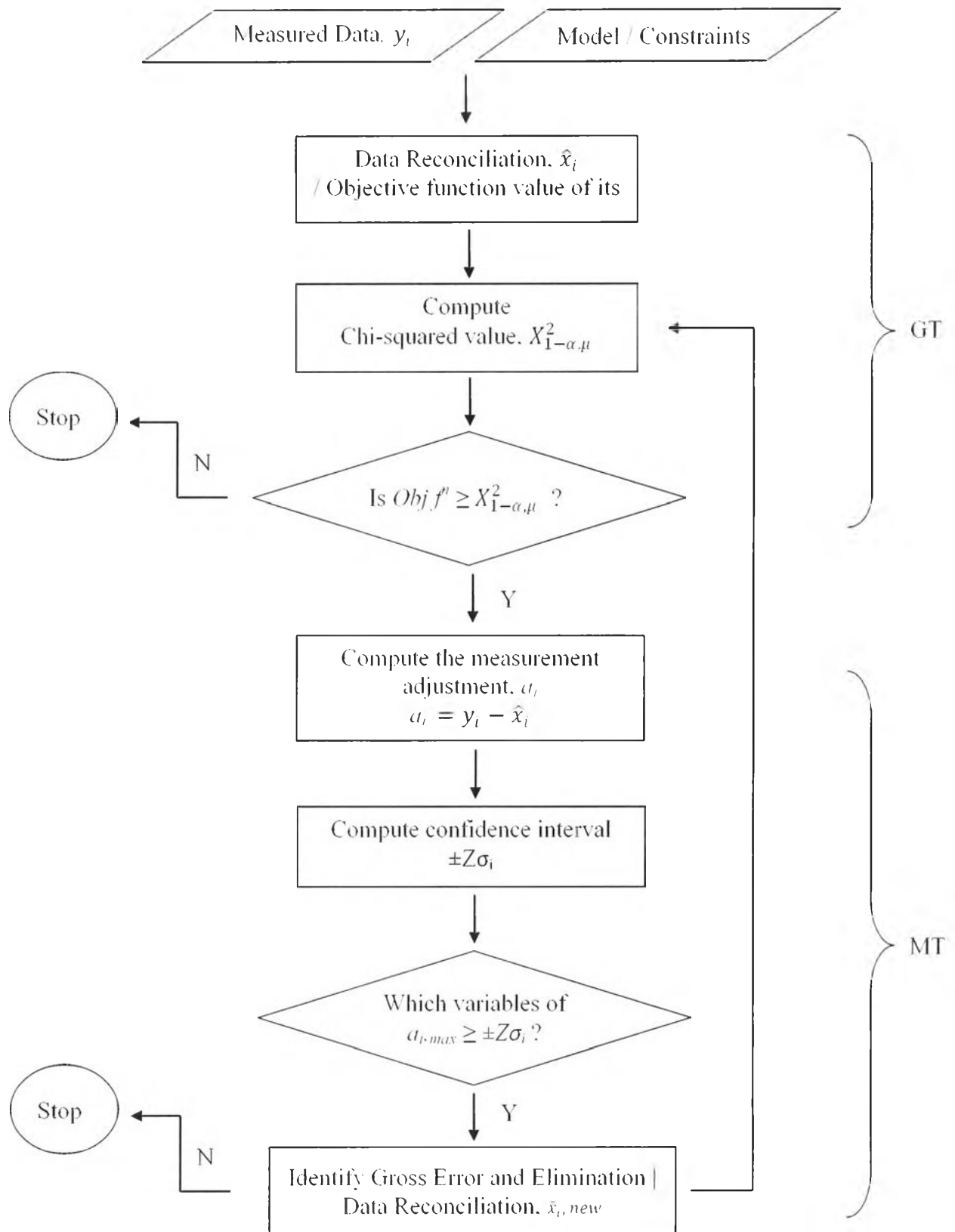

**Figure 4.4** The conventional gross error detection algorithm.

The assumption of the conventional gross error detection in this experiment was to use *level of significant at 10%\** (only confidence that 90%, the gross error are absent) to detect gross errors of a hot-oil heat exchanger (Model A) and the degree of freedom which used to find the Chi-squared value, is the same with degree of redundancy of a hot-oil heat exchanger, that is 2 in the first reconciliation. *\*1%, 5% and 10% level of significant are widely use in scientific model but this technique choose 10% level of significant because 1% and 5% level of significant is too stricter (<http://www.answers.com/topic/statistical-significance>)*

First, the objective function of first data reconciliation need to be checked by following the concept of global test techniques

**Table 4.9** Objective function of data reconciliation compared to Chi-squared distribution value of Model A

Condition of Gross error	Objective function	Chi-squared values*
1 position	16.892	6.251 / 4.605 / 2.706
2 position	10.148	6.251 / 4.605 / 2.706

*\*Chi-squared value at 10% level of significant with 3 to 1 degree of freedom*

From Table 4.9 showed objective functions of data reconciliation, the objective functions of first data reconciliation for both cases are greater than the Chi-squared values with 2 degree of freedom, so gross errors were detected in all systems above but we didn't know the positions of gross error, therefore the measurement test technique need to be used in the next step.

Concept of measurement test technique is to detect the gross error by using the following which is, if the measurement adjustment of which variables fall outside the confidence interval so it can be identified to contain gross error. The measurement adjustment, the estimator value and the confidence interval are shown in equation 4.12 to 4.14, respectively.

$$\text{Measurement adjustment } (a_i) = \text{reconciled value } (x_i) - \text{measured value } (y_i) \quad (4.12)$$

$$\%confidence\ level = erf\left(\frac{|Z|}{\sqrt{2}}\right) \quad (4.13)$$

Where  $Z$  is the estimator value  
 $Erf$  is the error function

$$Confidence\ interval = \pm (Z \times \sigma_i) \quad (4.14)$$

Where  $\sigma_i$  is the standard deviation of each variable

And the standard deviation of each variable can be calculated by using equation 4.15

$$\sigma_i = \sqrt{\frac{1}{n} \sum_{i=1}^n [x_i - \bar{x}]^2} \quad (4.15)$$

Where  $\sigma_i$  is the standard deviation of each variable  
 $n$  is the number of measured frequency  
 $x_i$  is the measured value  
 $\bar{x}$  is the mean of measured value

From assumption above, level of significant of 10% was used in this experiment, so the confidence level will be 90% and the estimator value will be around 1.64 calculated from equation 4.13 as well as the measurement adjustment and the confidence interval are shown in Tables 4.10 and 4.11.

**Table 4.10** Measurement adjustment and confidence interval of a hot-oil heat exchanger (Model A) with both random errors and one gross error only at  $F_o$

Condition of Gross error	Variable	Measurement Adjustment	Confidence interval
1 position	$F_o$	-58.022	$\pm 57.479$
	$F_{et}$	-2.716	$\pm 41.408$
	$T_{o,in}$	-6.871	$\pm 40.902$
	$T_{o,out}$	-2.311	$\pm 40.061$
	$T_{et,in}$	-0.918	$\pm 16.070$
	$T_{et,out}$	0	$\pm 16.792$

**Table 4.11** Measurement adjustment and confidence interval of a hot-oil heat exchanger (Model A) with both random errors and two gross errors at  $F_o$  and  $T_{et,in}$

Condition of Gross error	Variable	Measurement Adjustment	Confidence interval
2 position	$F_o$	-61.082	$\pm 57.479$
	$F_{et}$	0	$\pm 41.408$
	$T_{o,in}$	-1.207	$\pm 40.902$
	$T_{o,out}$	-3.827	$\pm 40.061$
	$T_{et,in}$	-25.129	$\pm 27.799$
	$T_{et,out}$	-0.478	$\pm 16.792$

From Table 4.10 because the measurement adjustment [-58.022] of hot-oil volumetric flowrate falls outside the confidence interval [ $\pm 57.479$ ] and the magnitude of its extremely faraway when compared to the others, so the measurement test technique indicate that the gross error exists at hot-oil volumetric flowrate variable and this variable will be discarded first in the next process.

From Table 4.11 because the measurement adjustment [-61.082] of



hot-oil volumetric flowrate falls outside the confidence interval  $[\pm 57.479]$  and the magnitude of its extremely faraway when compared to the others, so the measurement test technique indicate that the gross error exists at hot-oil volumetric flowrate variable and this variable will be discarded first in the next process.

Therefore, the variables as above that suspected to contain gross error must be discard in the next data reconciliation.

After discarding the variable mostly suspected to contain gross error and doing the data reconciliation again, the results of data reconciliation are shown in Tables 4.12 and 4.13

**Table 4.12** Second reconciliation of process variables in a hot-oil heat exchanger (Model A) after discarding the gross error in the first time (with both random errors and one gross error only at  $F_o$ )

Variable	Symbol	True value	Avg.Measured value	Reconciled values	Relative Error
Hot-oil volumetric flow rate ( $\text{m}^3/\text{h}$ )	$F_o$	39.384	99.701	37.291	5.613%
Ethane product volumetric flow rate ( $\text{m}^3/\text{h}$ )	$F_{et}$	35538.777	35540.356	35540.356	0.0044%
Hot-oil inlet temperature ( $^{\circ}\text{C}$ )	$T_{o,in}$	169.430	169.595	168.46	0.576%
Hot-oil outlet temperature ( $^{\circ}\text{C}$ )	$T_{o,out}$	101.112	100.371	94.564	6.924%
Ethane product inlet temperature ( $^{\circ}\text{C}$ )	$T_{et,in}$	15.723	16.402	14.102	11.495%
Ethane product outlet temperature ( $^{\circ}\text{C}$ )	$T_{et,out}$	58.612	58.702	58.036	0.992%
Heat duty of hot stream (W)	$Q$				
Heat duty of cold stream (W)	$Q$	1396813.653	-	1350869.487	3.401%
Heat duty of heat exchanger (W)	$Q$				
Overall heat transfer coefficient ( $\text{W m}^{-2}\text{C}^{-1}$ )	$U$	310.60	310.29	309.59	0.328%

Remark: Objective function value, calculated from Equation 4.3-1, is equal to 0.23

**Table 4.13** Second reconciliation of process variables in a hot-oil heat exchanger (Model A) after discarding the gross error in the first time (with both random errors and two gross errors at  $F_o$  and  $T_{et,m}$ )

Variable	Symbol	True value	Avg. Measured value	Reconciled values	Relative Error
Hot-oil volumetric flow rate ( $m^3/h$ )	$F_o$	39.384	99.701	36.572	7.689%
Ethane product volumetric flow rate ( $m^3/h$ )	$F_{et}$	35538.777	35540.356	35540.356	0.0044%
Hot-oil inlet temperature (°C)	$T_{o,in}$	169.430	169.595	168.534	0.532%
Hot-oil outlet temperature (°C)	$T_{o,out}$	101.112	100.371	93.508	8.132%
Ethane product inlet temperature (°C)	$T_{et,in}$	15.723	39.048	14.225	10.531%
Ethane product outlet temperature (°C)	$T_{et,out}$	58.612	58.702	57.937	1.165%
Heat duty of hot stream (W)	$Q$				
Heat duty of cold stream (W)	$Q$	1396813.653	-	1363966.964	2.408%
Heat duty of heat exchanger (W)	$Q$				
Overall heat transfer coefficient ( $W/m^2 \cdot C$ )	$U$	310.60	310.29	309.91	0.223%

*Remark: Objective function value, calculated from Equation 4.3-1, is equal to 4.462*

From Table 4.13, the objective functions of data reconciliation are 4.462, when comparing this value with the Chi-squared distribution value with 1 degree of freedom [2.706] by following the global test technique again, it shows that the objective function of data reconciliation are still greater the Chi-squared distribution value, therefore in this case still have gross errors existing in the system, but the third data reconciliation cannot be performed because degree of redundancy of them will be equal to 0, but in contrast from Table 4.12, the objective function of data reconciliation are 0.237, when comparing these values with the Chi-squared distribution value with 1 degree of freedom [2.706] by following the global test technique again, it shows that the objective functions of data reconciliation are less than the Chi-squared distribution value, so there are no gross errors existing anymore, it can complete this process.

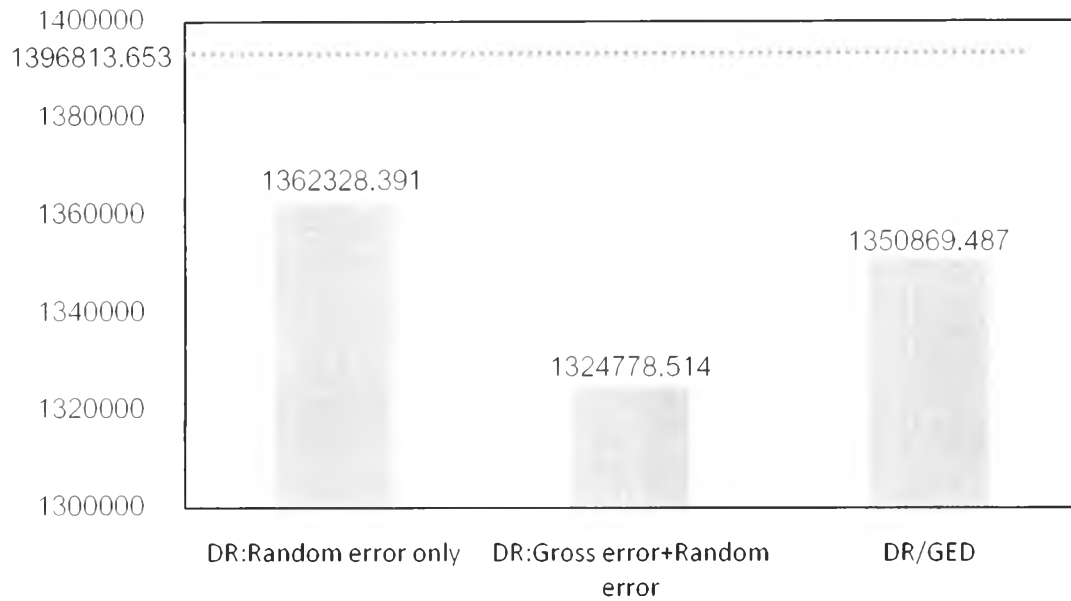

**Figure 4.5** True value and reconciled values: heat duty of system (with both random errors and one gross error only at  $F_{11}$ ).

And the performance evaluation for data reconciliation with gross error detection for Model A described below:

From Table 4.12, the performances between only data reconciliation and combination between data reconciliation and gross error detection were represented by standard deviation reduction value calculated from all measured variables (6 measured variable), its standard deviation reduction can be calculated by using equation 4.16 to 4.18 and the results are showed in Table 4.14.

Measurement error:

$$SD = \sqrt{\frac{\sum_{n=1}^n (X_{i,true} - X_{i,measured})^2}{n}} \quad (4.16)$$

Reconciled error:

$$SD = \sqrt{\frac{\sum_{n=1}^n (X_{i,true} - X_{i,reconciled})^2}{n}} \quad (4.17)$$

% SD reduction:

$$\% SD \text{ reduction} = \frac{SD_{\text{measurement error}} - SD_{\text{reconciled error}}}{SD_{\text{measurement error}}} \times 100 \quad (4.18)$$

**Table 4.14** Measurement error SD, reconciled error SD and standard deviation reduction of a hot-oil heat exchanger (Model A) with both random errors and one gross error only at  $F_o$

	DR: Only Random Error	DR: Random Error/Gross Error	DR/GED: Random Error/Gross Error
Measurement Error SD	60.347	60.347	60.347
Reconciled Error SD	5.159	7.820	7.336
Standard deviation Reduction	91.15%	87.04%	87.84%

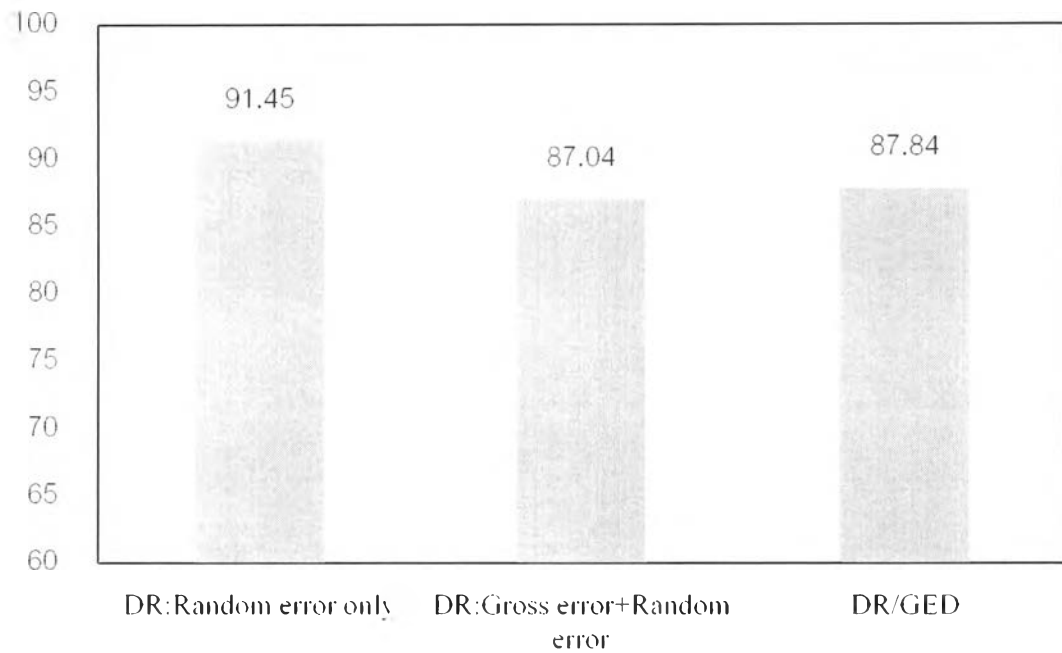

**Figure 4.6** Standard deviation reduction percentage of a hot-oil heat exchanger (Model A) with both random errors and one gross error only at  $F_o$

The standard deviation reduction percentage of 87.84% for doing data reconciliation with gross error detection is higher than one from only data reconciliation, which is 87.04%.

In case above shows that when the gross error detection technique was applied by doing with data reconciliation, basic gross error detection technique can enhance the performance of data reconciliation effectively.

#### 4.3.2 The Modified Measurement Test Using NLP Method

Concept of the modified measurement test using NLP method is to detect the systematic gross error or some bias, the purpose of this technique is same as the conventional gross error detection but it just was modified some steps. The algorithms of traditional measurement test, proposed by Mah and Tamhane (1982), as shown in Figure 4.7

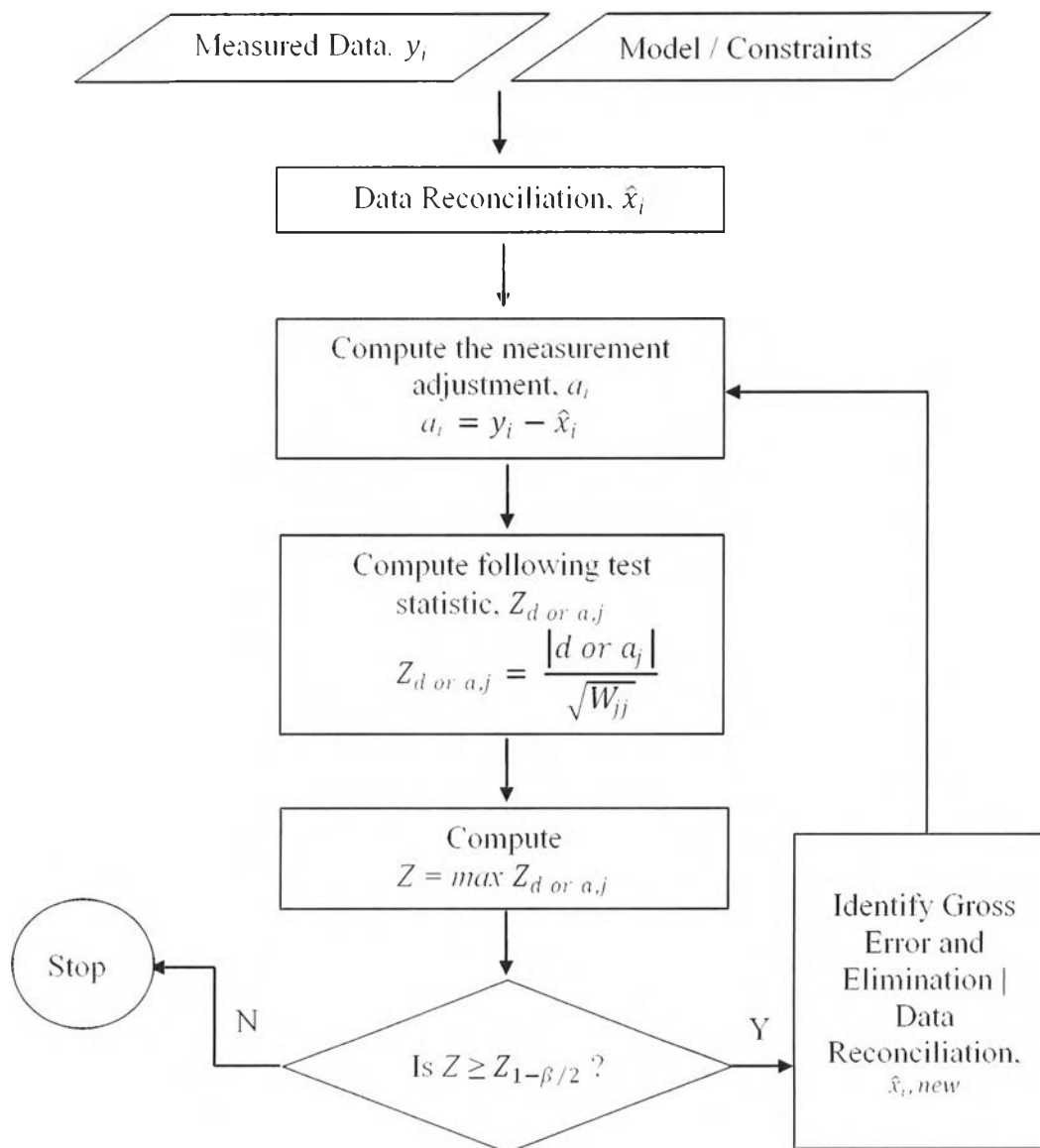

**Figure 4.7** The traditional measurement test algorithm. (Mah and Tamhane, 1982)

But this research uses the measurement test by modifying this technique with non-linear programming on data reconciliation steps (1<sup>st</sup> step of DR and final step of DR) but in some steps of gross error detection still is based on linearization as before.

First, the vector of balance matrix,  $A$  of a simulated model, need to be calculated and then the measurement adjustment of each variable represented as vector of measurement adjustment,  $a$ , will be found in the next step. It can be calculated by using equation 4.19

$$a = y - \hat{x} \quad (4.19)$$

Where  $y$  is measured value of each variable

$\hat{x}$  is the reconcile value of each variable

After that the variance-covariance matrix,  $V$ , will be found and it can be calculated by using equation 4.20

$$V = cov(r) = A \Sigma A^T \quad (4.20)$$

Where  $\Sigma$  is the measurement variance-covariance matrix

$A$  is the vector of balance matrix

And then the covariance matrix of measurement adjustment,  $W$ , will be found and it can be calculated by using equation 4.21

$$W = \Sigma A^T V^{-1} A \quad (4.21)$$

And the following test statistic can be calculated by using equation 4.22

$$Z_{d \text{ or } a, j} = \frac{|d \text{ or } a_j|}{\sqrt{W_d}} \quad j = 1, 2, \dots \quad (4.22)$$

From equations 4.22, we obtained the following test statistic of each variable for Model A in Tables 4.15-4.17 as shown below.

**Table 4.15** The following test statistic of a hot-oil heat exchanger (Model A) with only random errors occurring in the measurement for first DR

Condition of Gross error	Variable	The test statistical values, $Z_{d \text{ or } a_j}$
No Gross Error	$F_o$	1.4435
	$F_{et}$	0
	$T_{o,in}$	0.2221
	$T_{o,out}$	1.2857
	$T_{et,in}$	1.8007
	$T_{et,out}$	0.0480

**Table 4.16** The following test statistic of a hot-oil heat exchanger (Model A) with both random errors and one gross error only at  $F_o$  for first DR

Condition of Gross error	Variable	The test statistical values, $Z_{d \text{ or } a_j}$
1 position	$F_o$	17.7215
	$F_{et}$	1.1938
	$T_{o,in}$	2.2952
	$T_{o,out}$	0.7882
	$T_{et,in}$	0.7805
	$T_{et,out}$	0



**Table 4.17** The following test statistic of a hot-oil heat exchanger (Model A) with both random errors and one gross error only at  $F_o$  for second DR (after discarding  $F_o$  variable)

Condition of Gross error	Variable	The test statistical values, $Z_{d \text{ or } a_j}$
1 position	$F_o$	1.3431
	$F_{et}$	0
	$T_{o,in}$	0.3270
	$T_{o,out}$	2.0505
	$T_{et,in}$	2.0247
	$T_{et,out}$	0.5611

**Table 4.18** The following test statistic of a hot-oil heat exchanger (Model A) with both random errors and two gross errors at  $F_o$  and  $T_{et,m}$  for first DR

Condition of Gross error	Variable	The test statistical values, $Z_{d \text{ or } a_j}$
2 positions	$F_o$	18.6960
	$F_{et}$	0
	$T_{o,in}$	0.4416
	$T_{o,out}$	1.4296
	$T_{et,in}$	13.5277
	$T_{et,out}$	0.2573

**Table 4.19** The following test statistic of a hot-oil heat exchanger (Model A) with both random errors and two gross errors at  $F_o$  and  $T_{et,m}$  for second DR (after discarding  $F_o$  variable)

Condition of Gross error	Variable	The test statistical values, $Z_{d \text{ or } a_j}$
2 positions	$F_o$	0.6265
	$F_{et}$	0
	$T_{o,in}$	0.3722
	$T_{o,out}$	2.4582
	$T_{et,in}$	12.8131
	$T_{et,out}$	0.6537

The statistical test criterion can be chosen as  $Z_{1-\beta/2}$  where  $Z_{1-\beta/2}$  is the critical value of the standard normal distribution. For any specified value of  $\alpha$ , the modified level of significant,  $\beta$ , proposed by Mah and Tamhane (derived from Sidak inequality, 1967) can be compute using equation 4.23

$$\beta = 1 - (1 - \alpha)^{1/m} \quad (4.23)$$

Where  $m$  is the number of measured variables (or  $n$  used for MT step)  
 $\alpha$  is the chosen level of significant

The assumption of modified measurement test using NLP in this research was to use *level of significant at 10%\** (only confidence that 90%, the gross error are absent) to detect gross errors of a hot-oil heat exchanger (Model A)

*\*1%, 5% and 10% level of significant are widely use in scientific model but this technique choose 10% level of significant because 1% and 5% level of significant is too stricter (<http://www.answers.com/topic/statistical-significance>)*

And the statistical test criterions (refer to standard normal distribution) for each variable of Model A are shown in Table 4.20 as below.

**Table 4.20** The statistical test criterion for Model A (for 7, 6 and 5 variables, respectively)

Variable	Z at 10% level of significant
$F_o$	
$F_{et}$	
$T_{o,in}$	
$T_{o,out}$	2.440 / 2.380 / 2.310
$T_{et,in}$	
$T_{et,out}$	

From Tables 4.15 and 4.20, when all of the test statistical values of a hot-oil heat exchanger (Model A) were compared with the statistical test criterion, the all of test statistical values were less than the criterion value, so gross errors are not detected in this system.

From Tables 4.16, 4.18 and 4.20, when the test statistical values of each variable of a hot-oil heat exchanger (Model A) were compared with the statistical test criterion, it can show that the test statistical value of hot-oil volumetric flowrate for 1 position and 2 positions of gross error [17.7215, 18.6960] are greater than the statistical criterion [2.440] for the first time of DR, respectively and the magnitude of them extremely faraway from criterion, so this technique indicate that the gross error exists at hot-oil volumetric flowrate variable and this variable will be discarded first in the next process.

After discarding the hot-oil volumetric flowrate in both cases (1 position and 2 positions of gross error), the second data reconciliation was done, and the gross error detection results are shown in Tables 4.17 and 4.19, respectively

From Tables 4.17 and 4.20, when the test statistical values of each variable of a hot-oil heat exchanger (Model A) were compared with the statistical test

criterion, the all of statistical value were less than the statistical criterion [2.380] for the second time of DR, so the gross error was not detected anymore and the process was completed.

From Tables 4.18 and 4.20, when the test statistical values of each variable of a hot-oil heat exchanger (Model A) were compared with the statistical test criterion, it can show that the test statistical value of ethane product inlet temperature [12.8131] is greater than the statistical criterion [2.380] for the second time of DR and the magnitude of its extremely faraway from criterion, so this technique indicate that the gross error still existed at ethane product inlet temperature variable but the next reconciliation cannot be performed because DOR of this system is less than 1.

#### 4.3.3 The Performance Evaluation for Gross Error Detection Techniques

In evaluation of gross error detection algorithms, the following performance measure was used by Narasimhan and Mah (1987). The overall power of the method to identify gross errors correctly is given by

$$\text{Overall power} = \frac{\text{Number of gross errors correctly identified}}{\text{Number of gross errors simulated}} \quad (4.24)$$

**Table 4.21** The GED performance evaluation

GED Techniques	Overall power		
	No Gross error	1 position	2 positions
The conventional GED	0	1	0.5
The modified MT using NLP	0	1	1

From technique above, it cannot tell us that the gross error have still remained in the system or not until we will do the next reconciliation and do the gross error detection again, in this part we have just showed the performance of gross error detection between the conventional gross error detection and the modified measurement test using NLP method, and it can conclude that the performance of

gross error detection by using the modified measurement test using NLP method is the great one technique when compared to another one because this technique is very sensitive to detect the gross error in the system, it can detect all of gross errors occurring in the system but another one cannot, by using the same level of significant,  $\alpha$ , which used in the conventional gross error detection technique.

From Table 4.21 showed that the overall power of GED by using the conventional technique and the modified MT using NLP are equal to 1 and 1 for 1 position of gross error, respectively and equal to 0.5 and 1 for 2 positions of gross error, respectively. It can tell that the modified MT using NLP was more sensitively to detect gross error when compared to another one.

So, in the next session, the data reconciliation technique will be applied to reconcile the simulated measured data of utility heat exchanger network by using simulating model and the modified measurement test technique (Kim *et al.*, 1997) will be applied in gross error detection step.

## 4.4 Simulating Data of Utility Heat Exchanger Network

### 4.4.1 Generating Simulated Values (True Values)

#### **Model B:** Utility heat exchanger network

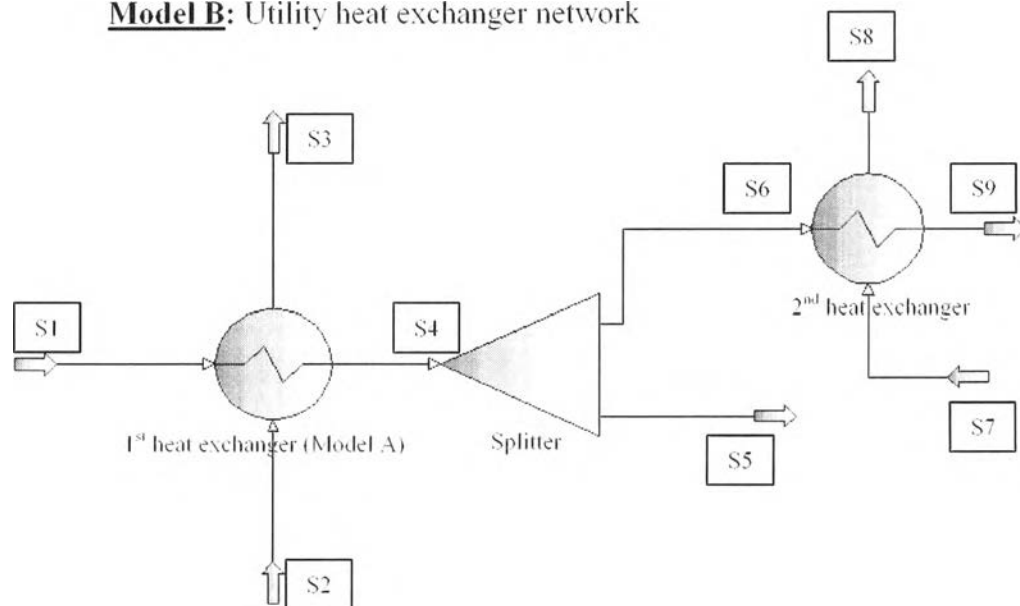

**Figure 4.8** The utility heat exchanger network flowcharts (Model B).

There are 13 measured variables of this utility heat exchanger network, and measured variables are shown below.

$F_o$  is volumetric flowrate of hot oil of stream s1 ( $\text{m}^3/\text{h}$ )

$F_{o,1}$  is volumetric flowrate of hot oil of stream s5 ( $\text{m}^3/\text{h}$ )

$F_{o,2}$  is volumetric flowrate of hot oil of stream s6 ( $\text{m}^3/\text{h}$ )

$T_{o1,m}$  is inlet temperature of hot oil of stream s1 ( $^{\circ}\text{C}$ )

$T_{o1,out}$  is outlet temperature of hot oil of stream s4 and inlet temperature of stream s5 and s6 ( $^{\circ}\text{C}$ )

$T_{o2,out}$  is outlet temperature of hot oil of stream s9 ( $^{\circ}\text{C}$ )

$F_{e1}$  is volumetric flowrate of ethane products of stream s2 ( $\text{Nm}^3/\text{h}$ )

$F_{e2}$  is volumetric flowrate of ethane products of stream s7 ( $\text{Nm}^3/\text{h}$ )

$T_{e1,m}$  is inlet temperature of ethane products of stream s2 ( $^{\circ}\text{C}$ )

$T_{et1,out}$  is outlet temperature of ethane products of stream s3 (°C)  
 $T_{et2,m}$  is inlet temperature of ethane products of stream s7 (°C)  
 $T_{et2,out}$  is outlet temperature of ethane products of stream s8 (°C)  
 and  $U_1$  is overall heat transfer coefficient of 1<sup>st</sup> heat exchanger system  
 (W/m<sup>2</sup> °C)

True values of each variable were generated by simulating utility heat exchanger network by combining a hot-oil heat exchanger Model A with another simulated hot-oil heat exchanger (used physical constant subscribe 2 for 2<sup>nd</sup> heat exchanger, shown in Table 4.22) and assumed that no heat loss around splitter unit, as shown in Figure 4.8

The physical constants and the all of simulated values (true values) of utility heat exchanger network (Model B) are shown in Tables 4.22 and 4.23, respectively.

**Table 4.22** Physical data of utility heat exchanger network (Model B)

Physical Data	Value
$C_{p,o1}$ (kJ/kg °C)	2.419
$\rho_{o,1}$ (kg/m <sup>3</sup> )	772.650
$C_{p,o2}$ (kJ/kg °C)	2.173
$\rho_{o,2}$ (kg/m <sup>3</sup> )	813.967
$C_{p,et1}$ (kJ/kg °C)	2.473
$\rho_{et1}$ (kg/m <sup>3</sup> )	1.334
$C_{p,et2}$ (kJ/kg °C)	2.199
$\rho_{et2}$ (kg/m <sup>3</sup> )	1.334
$A_1$ (m <sup>2</sup> )	46.1
$A_2$ (m <sup>2</sup> )	16.7

**Table 4.23** True values of utility heat exchanger network (Model B)

Variable	True value
$F_o$ (m <sup>3</sup> /h)	39.384
$F_{o,1}$ (m <sup>3</sup> /h)	9.384
$F_{o,2}$ (m <sup>3</sup> /h)	30.000
$F_{et,1}$ (m <sup>3</sup> /h)	35538.777
$F_{et,2}$ (m <sup>3</sup> /h)	35034.789
$T_{o1,in}$ (°C)	169.430
$T_{o1,out}$ (°C)	101.112
$T_{o2,out}$ (°C)	61.140
$T_{et1,m}$ (°C)	15.723
$T_{et1,out}$ (°C)	58.612
$T_{et2,m}$ (°C)	29.204
$T_{et2,out}$ (°C)	49.842
$U_1$ (W/m <sup>2</sup> °C)	310.60
$Q_1$ (W)	1396813.653
$U_2$ (W/m <sup>2</sup> °C)	863.80
$Q_2$ (W)	589181.315

#### 4.4.2 Generating Measured Values with Random and Gross Errors

The measured values of utility heat exchanger network (Model B) were generated by adding random errors and used the same assumptions of previous model (Model A) and the average measured values of model B are shown in Table 4.24.

**Table 4.24** Average measured values of utility heat exchanger network (Model B)

Variable	Standard deviation	Average Measured value
$F_o$ (m <sup>3</sup> /h)	10.094	40.093
$F_{o,1}$ (m <sup>3</sup> /h)	9.627	9.260



Variable	Standard deviation	Average Measured value
$F_{o,2}$ (m <sup>3</sup> /h)	9.734	29.240
$F_{et,1}$ (m <sup>3</sup> /h)	25.249	35540.356
$F_{et,2}$ (m <sup>3</sup> /h)	25.937	35033.151
$T_{ol,m}$ (°C)	24.940	169.595
$T_{ol,out}$ (°C)	24.428	100.371
$T_{o2,out}$ (°C)	24.445	61.750
$T_{et,m}$ (°C)	9.799	16.402
$T_{et,out}$ (°C)	10.239	58.702
$T_{et2,m}$ (°C)	10.057	29.544
$T_{et2,out}$ (°C)	9.581	50.371
$U_l$ (W/m <sup>2</sup> °C)	25.483	310.29

In the step of generating gross errors, this model used the same assumptions of previous model (Model A) and the average measured values with 2 positions of gross error (including gross error at  $F_o$  and  $T_{et,m}$ ) of Model B are shown in Table 4.25.

**Table 4.25** Measured values of utility heat exchanger network (Model B): including gross error at  $F_o$  and  $T_{et,m}$

Variable	Standard deviation	Average Measured value
$F_o$ (m <sup>3</sup> /h)*	36.227	99.701
$F_{o,1}$ (m <sup>3</sup> /h)	9.627	9.260
$F_{o,2}$ (m <sup>3</sup> /h)	9.734	29.240
$F_{et,1}$ (m <sup>3</sup> /h)	25.249	35540.356
$F_{et,2}$ (m <sup>3</sup> /h)	25.937	35033.151
$T_{ol,m}$ (°C)	24.940	169.595
$T_{ol,out}$ (°C)	24.428	100.371
$T_{o2,out}$ (°C)	24.445	61.750
$T_{et,m}$ (°C)*	16.951	39.048

Variable	Standard deviation	Average Measured value
$T_{et1,out}$ (°C)	10.239	58.702
$T_{et2,m}$ (°C)	10.057	29.544
$T_{et2,out}$ (°C)	9.581	50.371

#### 4.5 Data Reconciliation Technique (for Model B)

For utility heat exchanger network, there are 16 process variables which are  $F_o$  (hot-oil volumetric flowrate of stream s1),  $F_{o1}$  (hot-oil volumetric flowrate of stream s5),  $F_{o2}$  (hot-oil volumetric flowrate of stream s6),  $F_{et1}$  (ethane products volumetric flowrate of stream s2),  $F_{et2}$  (ethane products volumetric flowrate of stream s7),  $T_{o1,m}$  (inlet temperature of hot oil of stream s1),  $T_{o1,out}$  (temperature of hot oil of stream s4, s5 and s6),  $T_{o2,out}$  (outlet temperature of hot oil of stream s9),  $T_{et1,m}$  (inlet temperature of ethane products of stream s2),  $T_{et1,out}$  (outlet temperature of ethane products of stream s3),  $T_{et2,m}$  (inlet temperature of ethane products of stream s7),  $T_{et2,out}$  (outlet temperature of ethane products of stream s8),  $U_1$  (overall heat transfer coefficient of 1<sup>st</sup> heat exchanger),  $U_2$  (overall heat transfer coefficient of 2<sup>nd</sup> heat exchanger),  $Q_1$  (heat duty of 1<sup>st</sup> heat exchanger system) and  $Q_2$  (heat duty of 2<sup>nd</sup> heat exchanger system) and there are 3 equations for 1<sup>st</sup> heat exchanger system which are the heat duty of hot stream (hot oil), cold stream and 1<sup>st</sup> heat exchanger and 3 equations for 2<sup>nd</sup> heat exchanger system as shown in equation 4.26 to 4.31, respectively. Degree of freedom (DOF), which is the minimum number of variables required to calculate all system variables, or the difference between number of variables (including measured and unmeasured variables) and number of equations, need to be calculated, the other parameter called degree of redundancy (DOR) is the difference between number of measured variables and degree of freedom. Data reconciliation can be done if degree of redundancy is greater than or equal to 1 (DOR  $\geq 1$ ). The greater value of DOR represents more accuracy in doing the data reconciliation technique. DOF and DOR equation are shown in equation 4.1 and 4.2, respectively

For utility heat exchanger network (Model B)

$$\begin{aligned} \text{Degree of freedom (DOF)} &= \text{no. of variables} - \text{no. of equations} \\ &= 16 - 6 = 10 \end{aligned}$$

$$\begin{aligned} \text{Degree of redundancy (DOR)} &= \text{no. of measured variables} - \text{DOF} \\ &= 13 - 10 = 3 \end{aligned}$$

In the case of utility heat exchanger network (Model B), DOF is equal to 10 and DOR is equal to 3. To do data reconciliation, DOR must be greater than or equal to 1 ( $\text{DOR} \geq 1$ ) or we need at least 12 measured variables to do data reconciliation for this model at the beginning of eliminating gross error.

Data reconciliation of utility heat exchanger network (Model B) used the objective functions as shown in equation 4.25.

Objective function for utility heat exchanger network (Model B):

$$\begin{aligned} \text{Min } &\left(\frac{F_o - Fr_o}{\sigma_{F_o}}\right)^2 + \left(\frac{F_{o,1} - Fr_{o,1}}{\sigma_{F_{o,1}}}\right)^2 + \left(\frac{F_{o,2} - Fr_{o,2}}{\sigma_{F_{o,2}}}\right)^2 + \left(\frac{F_{et1} - Fr_{et1}}{\sigma_{F_{et1}}}\right)^2 + \left(\frac{F_{et2} - Fr_{et2}}{\sigma_{F_{et2}}}\right)^2 \\ &+ \left(\frac{T_{o1,in} - Tr_{o1,in}}{\sigma_{T_{o1,in}}}\right)^2 + \left(\frac{T_{o1,out} - Tr_{o1,out}}{\sigma_{T_{o1,out}}}\right)^2 + \left(\frac{T_{o2,out} - Tr_{o2,out}}{\sigma_{T_{o2,out}}}\right)^2 \\ &+ \left(\frac{T_{et1,in} - Tr_{et1,in}}{\sigma_{T_{et1,in}}}\right)^2 + \left(\frac{T_{et1,out} - Tr_{et1,out}}{\sigma_{T_{et1,out}}}\right)^2 + \left(\frac{T_{et2,in} - Tr_{et2,in}}{\sigma_{T_{et2,in}}}\right)^2 \\ &+ \left(\frac{T_{et2,out} - Tr_{et2,out}}{\sigma_{T_{et2,out}}}\right)^2 + \left(\frac{U_1 - Ur_1}{\sigma_{U_1}}\right)^2 \end{aligned} \quad (4.25)$$

Heat transfer of each system must be the same, so the actual heat transfer may be calculated by energy balance. Equation 4.26, 4.27, and 4.28 are heat duty of hot stream (hot oil), cold stream and heat exchanger of 1<sup>st</sup> heat exchanger system, respectively. Equation 4.29, 4.30, and 4.31 are heat duty of hot stream (hot oil), cold stream and heat exchanger of 2<sup>nd</sup> heat exchanger system, respectively. Equations 4.32 to 4.39 are inequality constraints.

Constraints for 1<sup>st</sup> heat exchanger system:

$$Q_1 = M_o C_{p,o} (T_{o1,out} - T_{o1,in}) \quad (4.26)$$

$$Q_1 = M_{et1} C_{p,et1} (T_{et1,out} - T_{et1,in}) \quad (4.27)$$

$$Q_1 = U_1 A_1 (LMTD)_1 \quad (4.28)$$

Constraints for 2<sup>nd</sup> heat exchanger system:

$$Q_2 = M_{o2} C_{p,o2} (T_{o2,out} - T_{o1,out}) \quad (4.29)$$

$$Q_2 = M_{et2} C_{p,et2} (T_{et2,out} - T_{et2,in}) \quad (4.30)$$

$$Q_2 = U_2 A_2 (LMTD)_2 \quad (4.31)$$

*\*Remark: All of heat capacities, areas and overall heat transfer coefficients are assumed to be constant*

Inequality constraints for 1<sup>st</sup> heat exchanger system:

$$T_{o1,in} \geq T_{et1,out} \quad (4.32)$$

$$T_{o1,out} \geq T_{et1,in} \quad (4.33)$$

$$T_{o1,in} \geq T_{o1,out} \quad (4.34)$$

$$T_{et1,out} \geq T_{et1,in} \quad (4.35)$$

Inequality constraints for 2<sup>nd</sup> heat exchanger system:

$$T_{o1,out} \geq T_{et2,out} \quad (4.36)$$

$$T_{o2,out} \geq T_{et2,in} \quad (4.37)$$

$$T_{o1,out} \geq T_{o2,out} \quad (4.38)$$

$$T_{et2,out} \geq T_{et2,in} \quad (4.39)$$

In this case, Chen's approximation (Chen, 1988) was used to calculate log-mean temperature difference by using equation as the same concept with previous model (Model A) and this equation is shown in equation 4.11.

In this work, General Algebraic Modeling System (GAMS) program was used to perform data reconciliation by minimizing the objective function (Equation.4.25) with the reconciled values of flow rates, inlet and outlet temperature of hot oil and cold process streams suitable for process constraints (Equation 4.26 to 4.39).

**Model B:****Table 4.26** First reconciliation of process variables in utility heat exchanger network (Model B) with only random errors occurring measurement

Variable	Stream	Symbol	True value	Avg.Measured value	Reconciled values	Relative Error
Hot-oil volumetric flow rate (m <sup>3</sup> /h)	S1	$F_o$	39.384	40.093	40.915	3.887%
Hot-oil volumetric flow rate (m <sup>3</sup> /h)	S5	$F_{o,1}$	9.384	9.260	9.260	1.321%
Hot-oil volumetric flow rate (m <sup>3</sup> /h)	S6	$F_{o,2}$	30.000	29.240	31.177	3.923%
Ethane product volumetric flow rate (m <sup>3</sup> /h)	S2	$F_{et,1}$	35538.777	35540.356	35540.368	0.0045%
Ethane product volumetric flow rate (m <sup>3</sup> /h)	S7	$F_{et,2}$	35034.789	35033.151	35033.140	0.0047%
Hot-oil inlet temperature (°C)	S1	$T_{o1,in}$	169.430	169.595	170.734	0.769%
Hot-oil outlet inlet temperature (°C)	S4-5-6	$T_{o1,out}$	101.112	100.371	101.656	0.538%
Hot-oil outlet temperature (°C)	S9	$T_{o2,out}$	61.140	61.750	63.007	3.054%
Ethane product inlet temperature (°C)	S2	$T_{et1,in}$	15.723	16.402	15.468	1.622%
Ethane product outlet temperature (°C)	S3	$T_{et1,out}$	58.612	58.702	60.701	3.564%
Ethane product inlet temperature (°C)	S7	$T_{et2,in}$	29.204	29.544	35.469	21.452%
Ethane product outlet temperature (°C)	S8	$T_{et2,out}$	49.842	50.371	43.833	12.056%
Heat duty of hot stream (W)		$Q_1$				
Heat duty of cold stream (W)	1 <sup>st</sup> hx	$Q_1$	1396813.653	-	1382620.711	1.016%
Heat duty of heat exchanger (W)		$Q_1$				
Heat duty of hot stream (W)		$Q_2$				
Heat duty of cold stream (W)	2 <sup>nd</sup> hx	$Q_2$	589181.315	-	573348.183	2.687%
Heat duty of heat exchanger (W)		$Q_2$				
Overall heat transfer coefficient (W m <sup>-2</sup> °C)	1 <sup>st</sup> hx	$U_1$	310.60	310.29	307.98	0.843%
Overall heat transfer coefficient (W m <sup>-2</sup> °C)	2 <sup>nd</sup> hx	$U_2$	863.80	-	841.29	2.606%

Remark: Objective function value, calculated from Equation 4.25, is equal to 0.920

**Table 4.27** First reconciliation of process variables in utility heat exchanger network (Model B) with both random errors and two gross errors at  $F_o$  and  $T_{et1m}$

Variable	Stream	Symbol	True value	Avg. Measured value	Reconciled values	Relative Error
Hot-oil volumetric flow rate ( $m^3/h$ )	S1	$F_o$	39.384	99.701	46.231	17.385%
Hot-oil volumetric flow rate ( $m^3/h$ )	S5	$F_{o,1}$	9.384	9.260	9.260	1.321%
Hot-oil volumetric flow rate ( $m^3/h$ )	S6	$F_{o,2}$	30.000	29.240	35.228	17.437%
Ethane product volumetric flow rate ( $m^3/h$ )	S2	$F_{et1}$	35538.777	35540.356	35540.387	0.0045%
Ethane product volumetric flow rate ( $m^3/h$ )	S7	$F_{et2}$	35034.789	35033.151	35033.140	0.0047%
Hot-oil inlet temperature ( $^{\circ}C$ )	S1	$T_{o1,in}$	169.430	169.595	162.326	4.193%
Hot-oil outlet inlet temperature ( $^{\circ}C$ )	S4 5 6	$T_{o1,out}$	101.112	100.371	105.473	4.313%
Hot-oil outlet temperature ( $^{\circ}C$ )	S9	$T_{o2,out}$	61.140	61.750	63.007	3.054%
Ethane product inlet temperature ( $^{\circ}C$ )	S2	$T_{et1,in}$	15.723	39.048	20.440	30.001%
Ethane product outlet temperature ( $^{\circ}C$ )	S3	$T_{et1,out}$	58.612	58.702	63.441	8.239%
Ethane product inlet temperature ( $^{\circ}C$ )	S7	$T_{et2,in}$	29.204	29.544	34.371	17.693%
Ethane product outlet temperature ( $^{\circ}C$ )	S8	$T_{et2,out}$	49.842	50.371	44.779	10.158%
Heat duty of hot stream (W)		$Q_1$				
Heat duty of cold stream (W)	1 <sup>st</sup> hx	$Q_1$	1396813.653	-	1299549.477	6.963%
Heat duty of heat exchanger (W)		$Q_1$				
Heat duty of hot stream (W)		$Q_2$				
Heat duty of cold stream (W)	2 <sup>nd</sup> hx	$Q_2$	589181.315	-	712115.368	20.865%
Heat duty of heat exchanger (W)		$Q_2$				
Overall heat transfer coefficient ( $W/m^2 \cdot ^{\circ}C$ )	1 <sup>st</sup> hx	$U_1$	310.60	310.29	307.13	1.118%
Overall heat transfer coefficient ( $W/m^2 \cdot ^{\circ}C$ )	2 <sup>nd</sup> hx	$U_2$	863.80	-	999.60	15.722%

*Remark: Objective function value, calculated from Equation 4.25, is equal to 4.693*

#### 4.6 Gross Error Detection (for Model B)

This model used only the traditional measurement test modified by using NLP to detect gross error, as described in the previous model (Model A) and the results are shown below.

**Table 4.28** The following test statistic of utility heat exchanger network (Model B) with both random errors and two gross errors at  $F_o$  and  $T_{et,m}$  for first DR

Variable	The test statistical values, $Z_{d \text{ or } a_j}$
$F_o$	14.6683
$F_{o,1}$	0
$F_{o,2}$	3.4868
$F_{et1}$	0.0122
$F_{et2}$	0.0035
$T_{o1,in}$	2.3913
$T_{o1,out}$	1.4335
$T_{o2,out}$	0.3963
$T_{et1,in}$	9.0067
$T_{et1,out}$	3.7974
$T_{et2,in}$	3.6991
$T_{et2,out}$	4.4983

From Tables 4.28 and 4.20, when the test statistical values of each variable of utility heat exchanger network (Model B) were compared with the statistical test criterion, it can show that the test statistical value of hot-oil volumetric flowrate [14.6683] are greater than the statistical criterion [2.440] for the first time of DR and the magnitude of its extremely faraway from criterion, so this technique indicate that the gross error exists at hot-oil volumetric flowrate variable and this variable will be discarded first in the next process.



**Table 4.29** Second reconciliation of process variables in utility heat exchanger network (Model B) after discarding  $F_o$  variable

Variable	Stream	Symbol	True value	Avg. Measured value	Reconciled values	Relative Error
Hot-oil volumetric flow rate ( $\text{m}^3/\text{h}$ )	S1	$F_o$	39.384	99.701	41.052	4.235%
Hot-oil volumetric flow rate ( $\text{m}^3/\text{h}$ )	S5	$F_{o,1}$	9.384	9.260	9.260	1.321%
Hot-oil volumetric flow rate ( $\text{m}^3/\text{h}$ )	S6	$F_{o,2}$	30.000	29.240	31.282	4.273%
Ethane product volumetric flow rate ( $\text{m}^3/\text{h}$ )	S2	$F_{et,1}$	35538.777	35540.356	35540.384	0.0045%
Ethane product volumetric flow rate ( $\text{m}^3/\text{h}$ )	S7	$F_{et,2}$	35034.789	35033.151	35033.140	0.0047%
Hot-oil inlet temperature ( $^{\circ}\text{C}$ )	S1	$T_{o1,in}$	169.430	169.595	165.532	2.301%
Hot-oil outlet inlet temperature ( $^{\circ}\text{C}$ )	S4 5 6	$T_{o1,out}$	101.112	100.371	101.679	0.561%
Hot-oil outlet temperature ( $^{\circ}\text{C}$ )	S9	$T_{o2,out}$	61.140	61.750	63.007	3.054%
Ethane product inlet temperature ( $^{\circ}\text{C}$ )	S2	$T_{et1,in}$	15.723	39.048	20.440	30.001%
Ethane product outlet temperature ( $^{\circ}\text{C}$ )	S3	$T_{et1,out}$	58.612	58.702	63.181	7.795%
Ethane product inlet temperature ( $^{\circ}\text{C}$ )	S7	$T_{et2,in}$	29.204	29.544	35.450	21.387%
Ethane product outlet temperature ( $^{\circ}\text{C}$ )	S8	$T_{et2,out}$	49.842	50.371	43.848	12.026%
Heat duty of hot stream (W)		$Q_1$				
Heat duty of cold stream (W)	1 <sup>st</sup> hx	$Q_1$	1396813.653	-	1292207.571	7.489%
Heat duty of heat exchanger (W)		$Q_1$				
Heat duty of hot stream (W)		$Q_2$				
Heat duty of cold stream (W)	2 <sup>nd</sup> hx	$Q_2$	589181.315	-	575619.793	2.302%
Heat duty of heat exchanger (W)		$Q_2$				
Overall heat transfer coefficient ( $\text{W}/\text{m}^2\text{C}$ )	1 <sup>st</sup> hx	$U_1$	310.60	310.29	306.72	1.250%
Overall heat transfer coefficient ( $\text{W}/\text{m}^2\text{C}$ )	2 <sup>nd</sup> hx	$U_2$	863.80	-	844.31	2.257%

*Remark: Objective function value, calculated from Equation 4.25, is equal to 2.300*

**Table 4.30** The following test statistic of utility heat exchanger network (Model B) with both random errors and two gross errors at  $F_o$  and  $T_{et1,m}$  for second DR (after discarding  $F_o$  variable)

Variable	The test statistical values, $Z_d$ or $a_j$
$F_o$	1.4207
$F_{o,1}$	0
$F_{o,2}$	1.1890
$F_{et1}$	0.0110
$F_{et2}$	0.0035
$T_{o1,in}$	1.3366
$T_{o1,out}$	0.3675
$T_{o2,out}$	0.3963
$T_{et1,in}$	9.0067
$T_{et1,out}$	3.5891
$T_{et2,in}$	4.5260
$T_{et2,out}$	5.2472

From Tables 4.30 and 4.20, when the test statistical values of each variable of utility heat exchanger network (Model B) were compared with the statistical test criterion, it can show that the test statistical value of ethane products inlet temperature of stream s2 [9.0067] are greater than the statistical criterion [2.380] for the second time of DR and the magnitude of its extremely faraway from criterion, so this technique indicate that the gross error still existed at ethane products inlet temperature of stream s2 variable and this variable will be discarded first in the next process

**Table 4.31** Final reconciliation of process variables in utility heat exchanger network (Model B) after discarding variable  $T_{et,1in}$

Variable	Stream	Symbol	True value	Avg.Measured value	Reconciled values	Relative Error
Hot-oil volumetric flow rate ( $m^3/h$ )	S1	$F_o$	39.384	99.701	41.052	4.235%
Hot-oil volumetric flow rate ( $m^3/h$ )	S5	$F_{o,1}$	9.384	9.260	9.260	1.321%
Hot-oil volumetric flow rate ( $m^3/h$ )	S6	$F_{o,2}$	30.000	29.240	31.282	4.273%
Ethane product volumetric flow rate ( $m^3/h$ )	S2	$F_{et1}$	35538.777	35540.356	35540.359	0.0045%
Ethane product volumetric flow rate ( $m^3/h$ )	S7	$F_{et2}$	35034.789	35033.151	35033.140	0.0047%
Hot-oil inlet temperature ( $^{\circ}C$ )	S1	$T_{o1,in}$	169.430	169.595	172.483	1.801%
Hot-oil outlet inlet temperature ( $^{\circ}C$ )	S4 5 6	$T_{o1,out}$	101.112	100.371	101.814	0.694%
Hot-oil outlet temperature ( $^{\circ}C$ )	S9	$T_{o2,out}$	61.140	61.750	63.007	3.053%
Ethane product inlet temperature ( $^{\circ}C$ )	S2	$T_{et1,in}$	15.723	39.048	12.900	17.954%
Ethane product outlet temperature ( $^{\circ}C$ )	S3	$T_{et1,out}$	58.612	58.702	59.431	1.397%
Ethane product inlet temperature ( $^{\circ}C$ )	S7	$T_{et2,in}$	29.204	29.544	35.434	21.332%
Ethane product outlet temperature ( $^{\circ}C$ )	S8	$T_{et2,out}$	49.842	50.371	43.862	11.997%
Heat duty of hot stream (W)		$Q_1$				
Heat duty of cold stream (W)	1 <sup>st</sup> hx	$Q_1$	1396813.653	-	1430314.534	2.398%
Heat duty of heat exchanger (W)		$Q_1$				
Heat duty of hot stream (W)		$Q_2$				
Heat duty of cold stream (W)	2 <sup>nd</sup> hx	$Q_2$	589181.315	-	577625.236	1.961%
Heat duty of heat exchanger (W)		$Q_2$				
Overall heat transfer coefficient ( $W/m^2 \cdot C$ )	1 <sup>st</sup> hx	$U_1$	310.60	310.29	308.72	0.605%
Overall heat transfer coefficient ( $W/m^2 \cdot C$ )	2 <sup>nd</sup> hx	$U_2$	863.80	-	846.04	2.056%

*Remark: Objective function value, calculated from Equation 4.25, is equal to 0.877*

**Table 4.32** The following test statistic of utility heat exchanger network (Model B) with both random errors and two gross errors at  $F_o$  and  $T_{et1,m}$  for final DR

Variable	The test statistical values, $Z_{d \text{ or } a_j}$
$F_o$	0
$F_{o,1}$	0
$F_{o,2}$	1.1890
$F_{et1}$	0.0012
$F_{et2}$	0.0035
$T_{o1,in}$	0.9501
$T_{o1,out}$	0.4054
$T_{o2,out}$	0.3963
$T_{et1,in}$	3.6495
$T_{et1,out}$	0.5842
$T_{et2,in}$	4.5137
$T_{et2,out}$	5.2359

From Tables 4.31 and 4.20, when the test statistical values of each variable of utility heat exchanger network (Model B) were compared with the statistical test criterion, the statistical value of ethane products outlet temperature of stream  $s7$  is still higher than the statistical criterion [2.310] for the third time (final time) of DR (depending on the limitation of DOR, DR cannot be performed in this system in the next time because DOR is less than 1), so this variable can be still identified to contain gross error but in fact, it should be completely done, meaning that the all of values which are detected, should be less than the criterion value. This problem can be always occur in the process, it can be called this error that Type I error, so we can solve this problem by many methods such as crosschecking with another GED method, using Sidak inequality or balancing the test criterion under the null hypothesis.

When the process was crosschecked with another GED method, this process can be assumed that DR with GED has done by using the conventional technique in GT step: the objective function [0.877] is extremely less than the Chi-squared value with 1 degree of freedom [2.706] from Table 4.9, so in the next section the performance evaluation of data reconciliation for Model B will be analyzed.

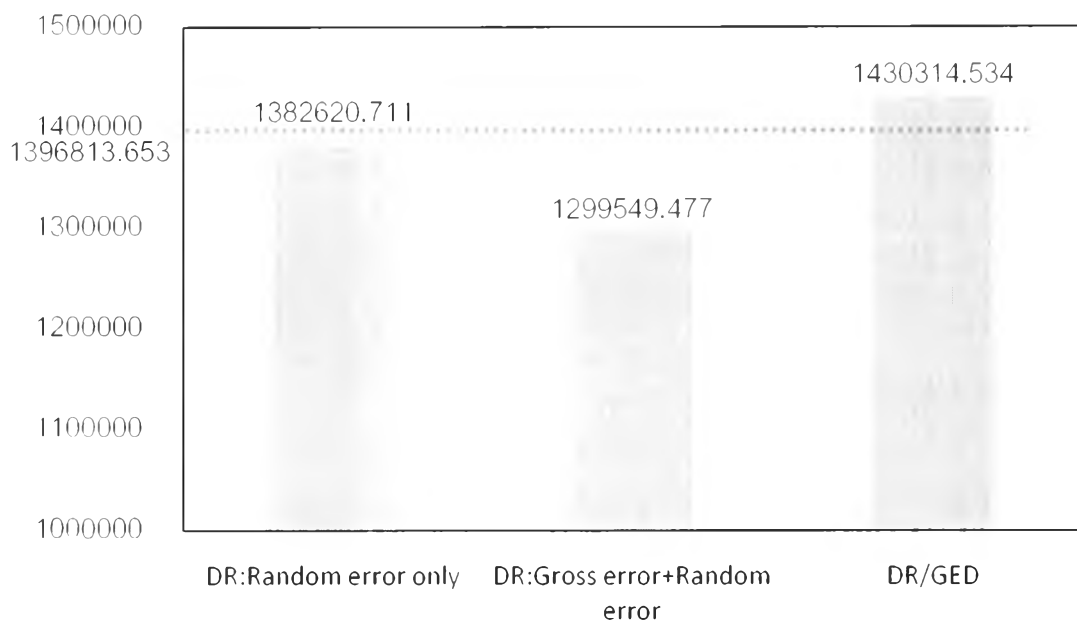

**Figure 4.9** True value and reconciled values: heat duty of 1<sup>st</sup> heat exchanger system.

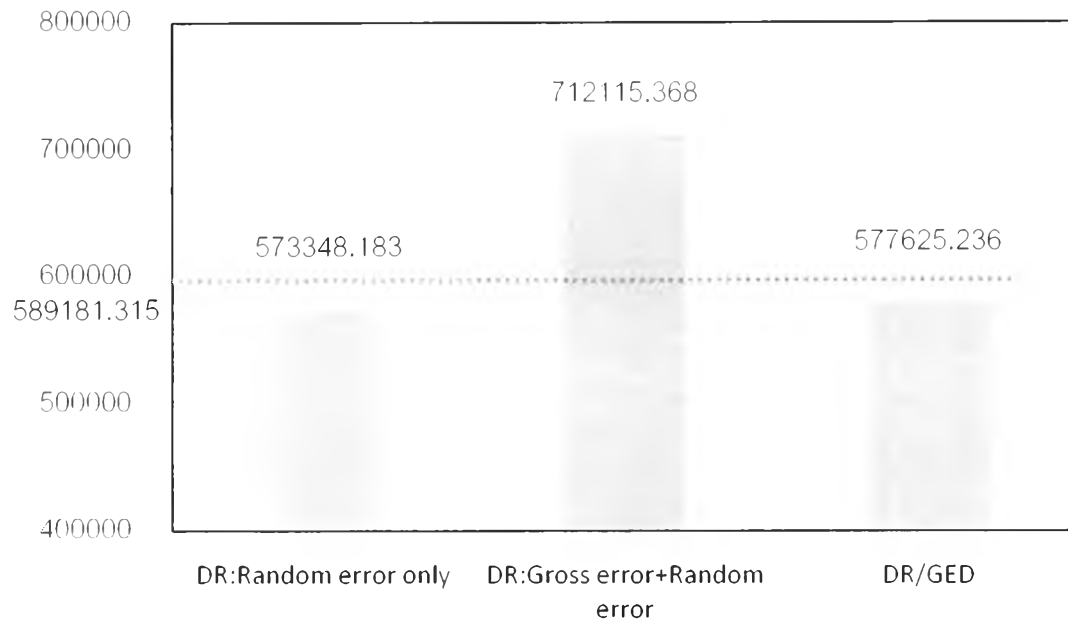
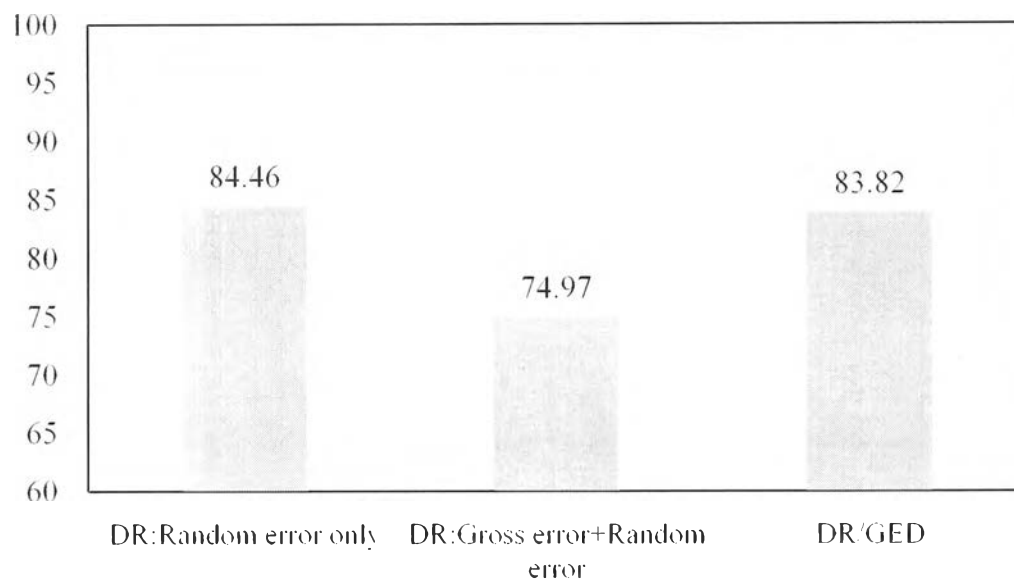

**Figure 4.10** True value and reconciled values: heat duty of 2<sup>nd</sup> heat exchanger system.

And the performance evaluation for data reconciliation with gross error detection for Model B showed below.

**Table 4.33** Measurement error SD, reconciled error SD and standard deviation reduction of utility heat exchanger network (Model B)

	DR: Only Random Error	DR: Random Error/Gross Error	DR/GED: Random Error/Gross Error
Measurement Error SD	17.9517	17.9517	17.9517
Reconciled Error SD	2.7889	4.4933	2.9050
Standard deviation Reduction	84.46%	74.97%	83.82%



**Figure 4.11** Standard deviation reduction percentage of utility heat exchanger network (Model B).

The standard deviation reduction percentage of 83.82% for doing data reconciliation with gross error detection is higher than one from only data reconciliation, which is 74.97%

In case above shows that when the gross error detection technique was applied by doing with data reconciliation, gross error detection technique can enhance the performance of data reconciliation effectively as the same with previous model.